

REGADA s. r. o., Strojnícka 7, Prešov

***Katalóg náhradných dielov
Typ MTR Variant, t.č. 52 420***

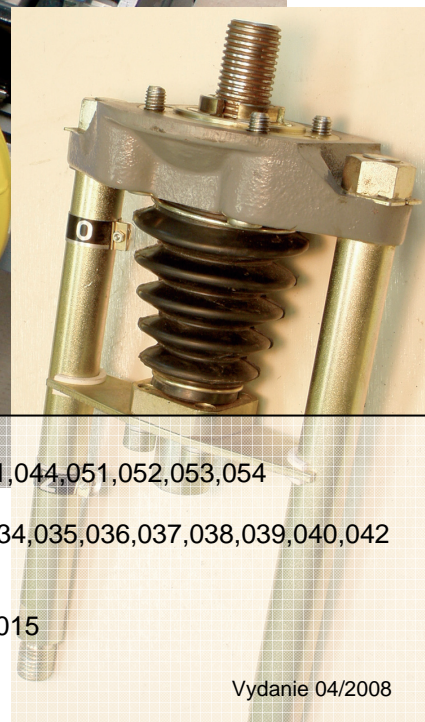
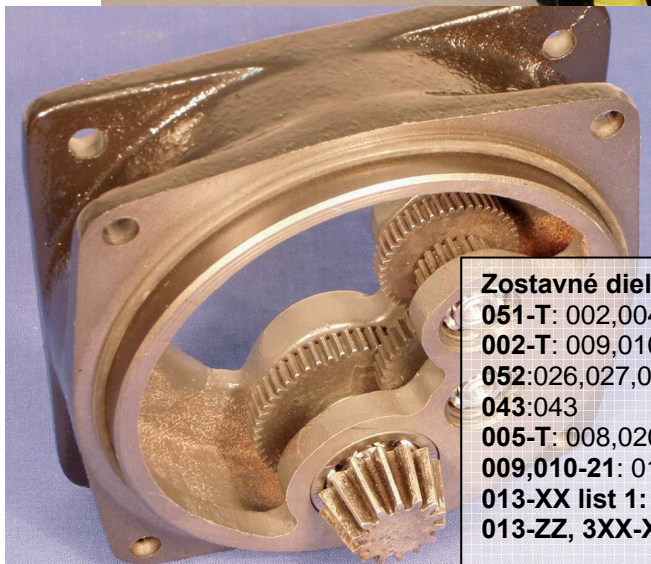
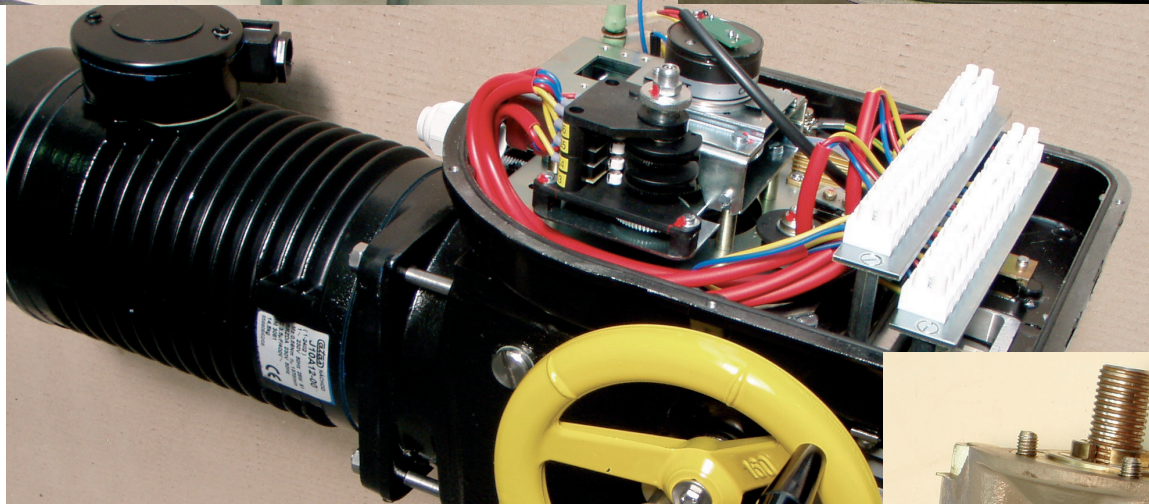
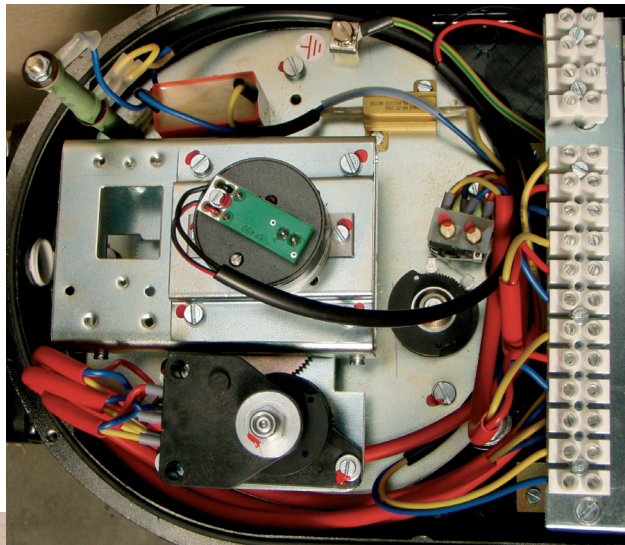
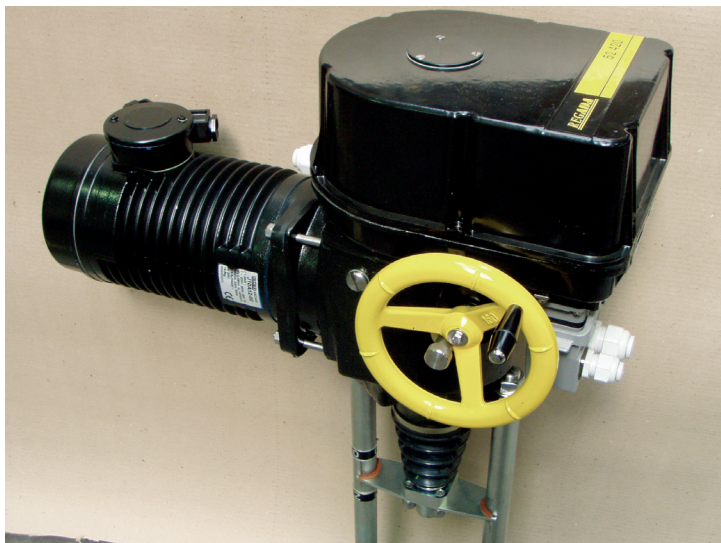

Zostavné diely podľa listov:

051-T: 002,004,005,007,008,020,023,041,044,051,052,053,054

002-T: 009,010,012,016,017,018-5,019

052: 026,027,028,029,030,031,032,033,034,035,036,037,038,039,040,042

043: 043

005-T: 008,020,025,041

009,010-21: 011,011-1,011-2,013,014-1,015

013-XX list 1: 013-01 až 013-99

013-ZZ, 3XX-XX list 2: 301 až 311-09

Vydanie 04/2008

002-T Silový prevod MTR

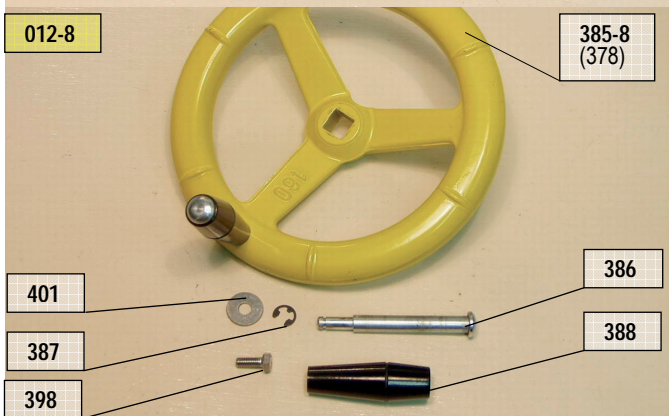
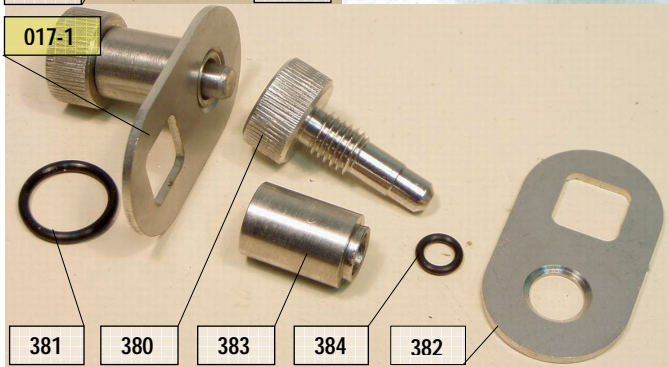
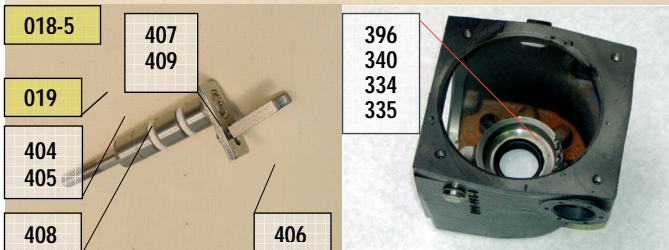
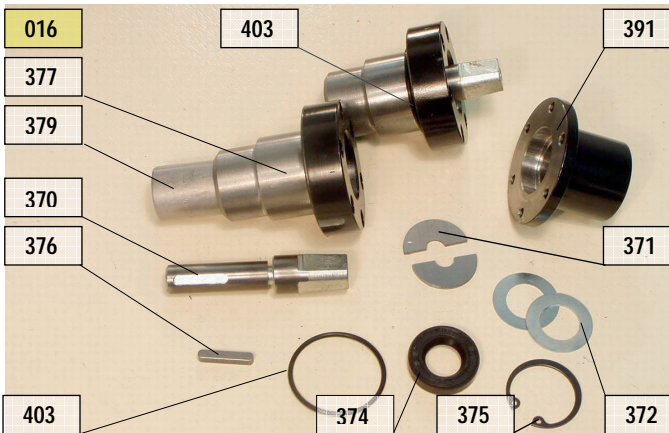
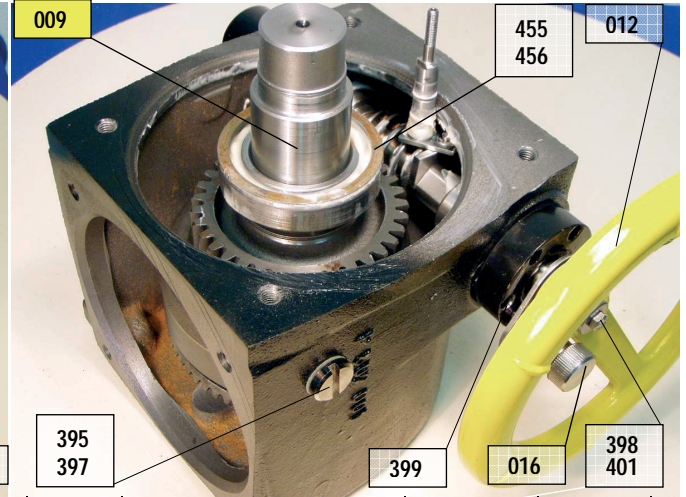
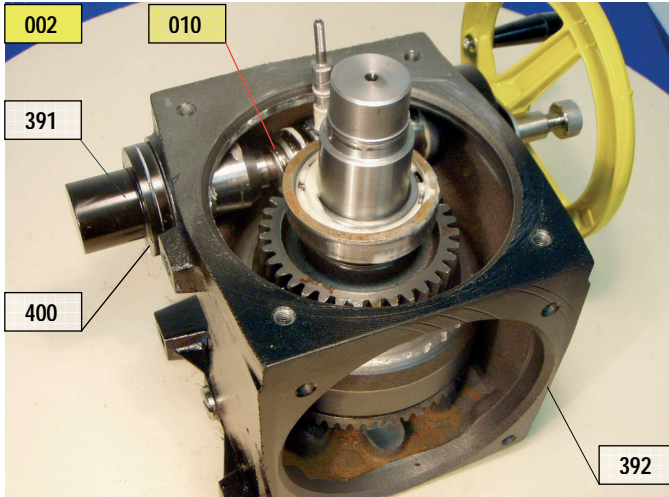

Poz.	Názov	PNm	Poznámky
002-XX	Prevod silový	2245640XX	špec. text.
009-XX	Zostava hriadeľa	2245025XX	špec. text.
010-XX	Závitovka zostava	2245026XX	špec. text.
012-08	Koleso ručné s výrezom	224834608	
016-02	Hriadeľ s aretáciou	224564202	
017-1	Kľuka aretácie	224A11101	
018-5	Ovládač momentový	224502705	
019	Hriadeľ s páčkou	224745100	
334	Podložka	244511600	
335	Podložka dištančná	244517000	
340	LOZISKO 6008	663243024	
370-X	HRIADELKA	20463040X	špec. text.
371	SEGMENT	204630500	
372	PODLOZKA	204630600	
373	PUZDRO II S VLOZKOU-BEZOV	224581301	
374	KR ŽOKGUFERO 16X28X7	662735044	
375	KRUZOK POIST FE 28	663111801	
376	PERO 4X4X22	663152068	
377	PUZDRO II	204630302	
378	RUCNE KOLO /20DL01010/	244731800	
379	PUZDRO KU 20X30	663243161	
380	SKRUTKA ARETACIE	204970600	
381	KRUZOK 20X16	662732063	
382	RAMENO ARETACIE	204970800	
383	MATICA ARETACIE	204970700	
384	KRUZOK 6.9X1.8	662732191	
385-X	KOLESO RUCNE	24473170X	špec. text.
386	CAP RUKOVATE	244732000	
387	KRUZOK FE 5	663112049	
388	RUKOVAT 8	663210015	
389	PODLOZKA DISTANCNA	244831900	
390	PODLOZKA DISTANCNA	244832000	
391	KRYTKA	204867700	
392-7	SKRINA MTR D 102	204764007	špec. text.
395-1	ZATKA	244833701	
396	KRÚŽOK GUFERO 40X52X7 GP	662735043	
397	PODLOZKA BA 50 D 14X19X2	662732325	
398	SKRUTKA FE M 5X12-A2	663117040	
399	SKRUTKA FE M 4X12-A2	663117805	
400	SKRUTKA FE M 4X20-A2	663117809	
401	PODLOZKA FE M 5,5-A2	663117400	
403	KRUZOK 34X2	662732109	
404	HRIADEL M. J.	204785700	
405	PACKA	244514100	
406	UNASAC	244514300	
407	PODLOZKA	244840200	
408	KRUŽOK 10X6 MVQ	662732022	
409	KRUZOK FE 3,2	663111720	
455	PODLOZKA DISTANCNA	244831600	
456	PODLOZKA DISTANCNA	244831700	

005-T Zostava riadiacej skrine MTR Variant

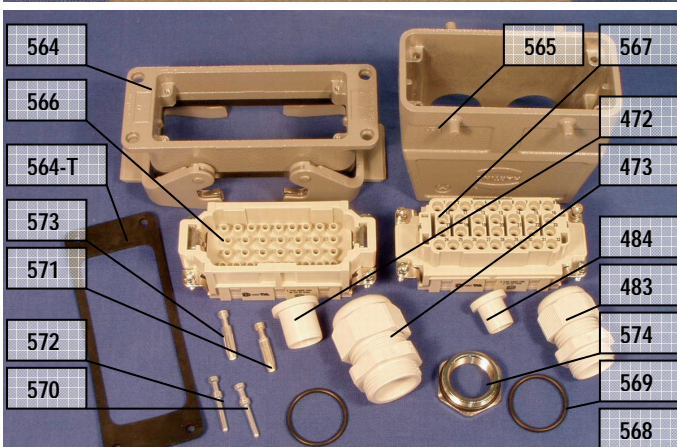
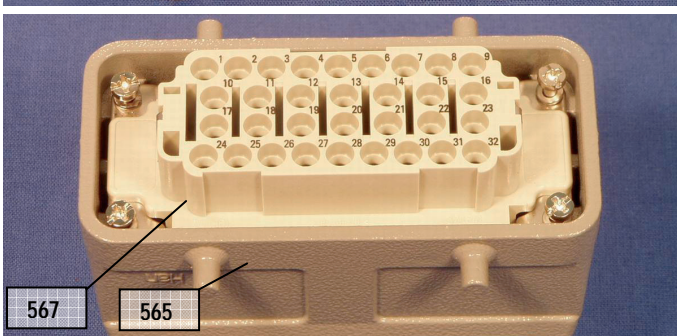
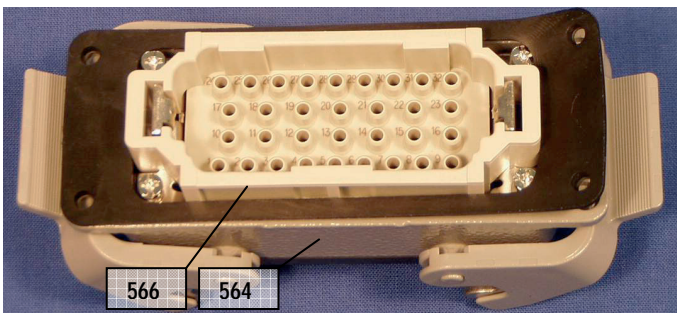
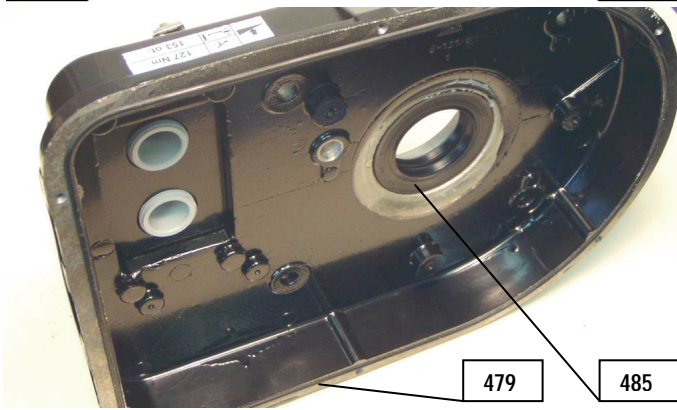
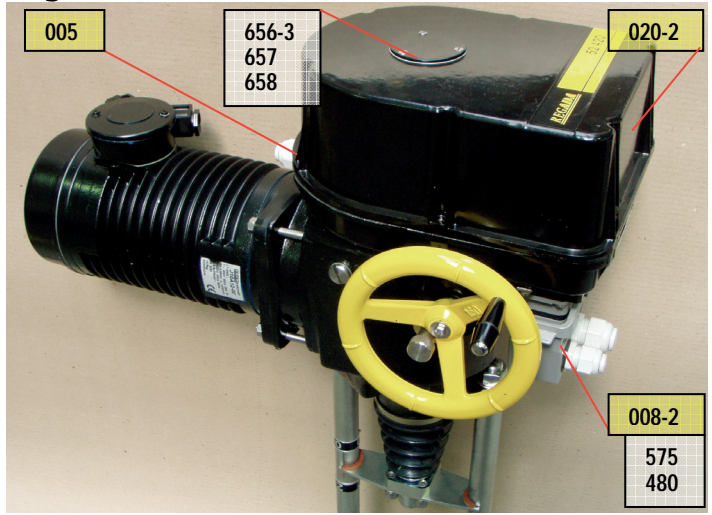
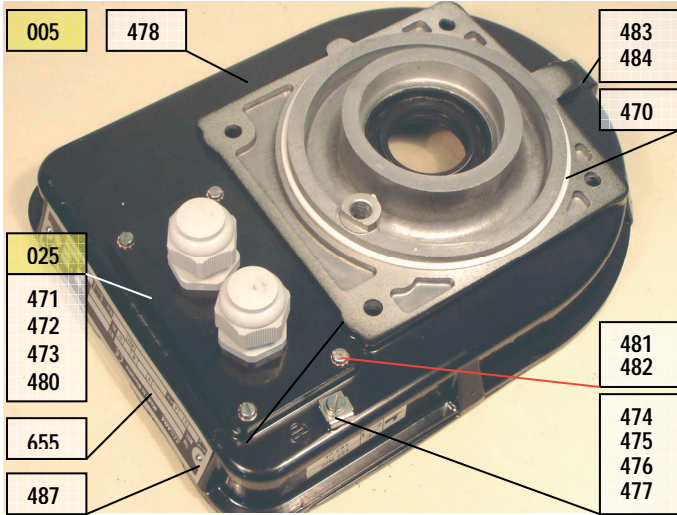

Poz	Názov	PNm	Poznámky
005-01	SKRINA RIADIACA-VYVODKY	224A21101	IP 65 MPR, MTR
005-04	SKRINA RIADIACA-KONEKTOR	224A21104	IP 65 MPR, MTR
005-22	SKRINA RIADIACA-VYVODKY	224A21122	IP 55 MPR, MTR
005-25	SKRINA RIADIACA-KONEKTOR	224A21125	IP 55 MPR, MTR
008-X	ZOSTAVA KONEKTOROV-HARTING	224A0020X	špec. textom
020-2	KRYT RIADIACEJ SKRINE IP 65	224572202	výsok.pre krát. hriad
025-X	DOSKA S VYVODKAMI-CIERNA	224A2070X	špec. textom
041-X	SVORKOVNICA ZOSTAVA-S	224A0690X	špec. textom
470	KRUZOK 130X3	662732095	
471-2	DOSKA-OPRACOVANIE	204A01402	
472	OCHR.KRYTKA TESNIACA M25X1,5	663457028	
473	VYVODKA KÁBELOVÁ M 25X1,5	663457017	
474	PODLOZKA	244503400	
475	PODLOZKA	244532500	
476	PODLOZKA FE M 5	663117452	
477	SKRUTKA MS M 5X10	663118109	
478-12	SKRINA RIADIACA	204A78312	IP 65 KON-VYV
478-01	SKRINA RIADIACA	204A78301	IP 55 KON-VYV
479	TESNENIE RIADIACEJ SKRINE	604A05199	
480	TESNENIE	604A04799	
481	SKRUTKA FE M 4X12-A2	663117735	
482	PODLOZKA MS 4,3	663118624	
483	VYVODKA KÁBELOVÁ M 20X1,5	663457013	
484	OCHR.KRYTKA TESNIACA M20X1,5	663457025	
485	GUFERO GP 40X62X7	662735002	
487	RYH. KLINEC FE 2,49X4,76-NI	663111904	
564	KRYT PANELOVY HAN 16B	663456695	
564-T	KRYT PANELOVY HAN 16B	663456695	tesnenie súčastou
565	TELESO KONEKT. M25 BOČNE	663456755	
566	ZASUVKA HAN 32 EE-M	663456713	
567	VIDLICA HAN 32 EE-F	663456712	
568	KRUZOK 22X2	662732046	
569	KRUZOK 20X2	662731034	
570	KOLIK 0.5 MM2	663456714	
571	DUTINKA 0.5 MM2	663456715	
572	KOLIK 1 MM	663456718	
573	DUTINKA 1 MM	663456719	
574	REDUKCIA RS-MSM25X1,5/M20X1,5	663457081	
575	SKRUTKA MS M 4X20	663118106	upevnenie konektora
576-X	STLPIK DISTANCNY MO-SVORKOVNCA	20495260X	03, 04
577	PLECH	204598400	
578-X	PLECH SVORKOVNICE	20495220X	01
579	SVORKOVNICA LTA 12-4 OP TXP310P	663456709	
580	MATICA FE M 4-ZN-8.8	663111542	
581	PODLOZKA FE 3,2-ZN	663111701	
582	SKRUTKA FE M 4X8	663111298	
583-12	STITOK SVORKOVNICE	204959612	
583-13	STITOK SVORKOVNICE	204959613	
583-14	STITOK SVORKOVNICE	204959614	
583-15	STITOK SVORKOVNICE	204959615	
655-2	STITOK TYPOVY 52 420	244536302	
656-3	VEKO-CIERNE	244532703	
657	TESNENIE	244532100	
658	SKRUTKA FE M 4X10-A2-70	663117804	

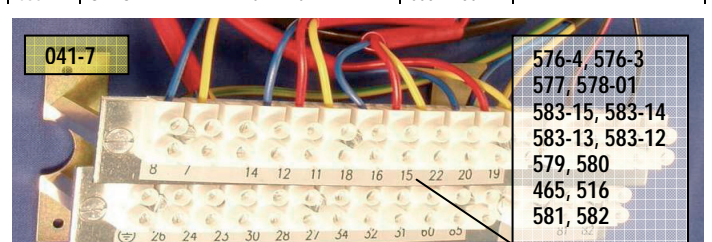

009-XX Zostava hriadeľa 224 5025 XX

10-XX Závitovka zostava 224 5026 XX

List 1/1

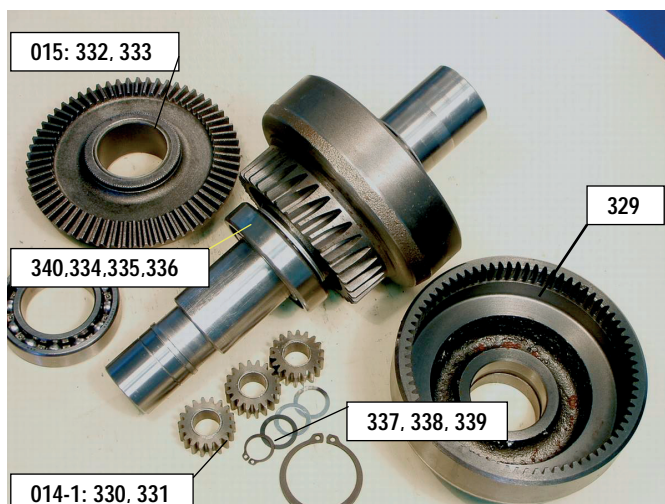
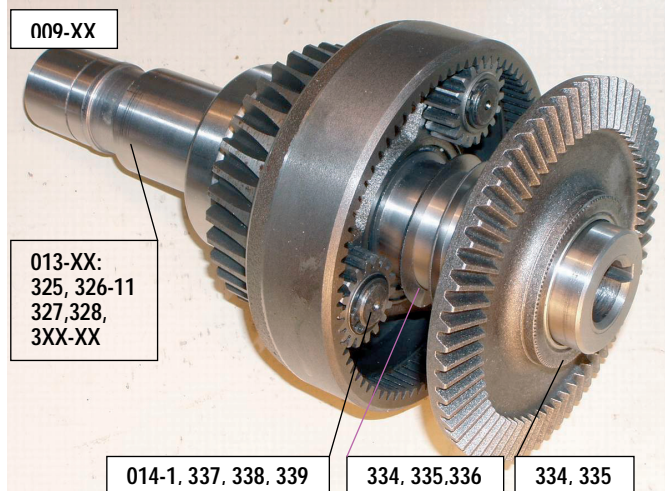

010-21 Závitovka zostava 224 5026 21(XX)

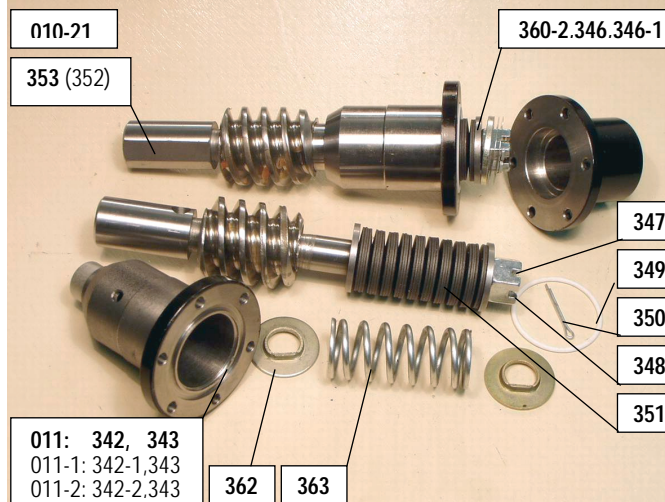

009-XX	Zostava hriadeľa	2245025XX	špecifikovať textom
010-XX	Závitovka zostava	2245026XX	špecifikovať textom
011	Puzdro s vložkou	224581400	
011-1	Puzdro s vložkou	224581401	
011-2	Puzdro s vložkou	224581402	
013-XX	Hriadeľ s unášačom	2245024XX	viď 013-XX
014-1	Satelit	224502901	
015	Koleso kuželové	224503000	
3XX-XX	Výstupný hriadeľ	2XXXXXXX	viď 3XX-XX

325-13	Unášač 3 drážky	244511913	√ 013-XX
326-11	Čap	244512011	√ 013-XX
327	Kružok poistný FE 40	663111966	√ 013-XX
328	Pero 8x7x20	663152070	√ 013-XX

02	341-1,345,346,347,348,349,350,352,354,355,356,357,359
03	341-1,346,347,348,349,350,352,354,355,356,357,359
04	341-1,346,347,348,349,350,352,354,355,356,358,359
05	341-1,345,346,347,348,349,350,352,354,355,356,359
06	341-1,346,347,348,349,350,352,354,355,356,359
07	341-1,346,347,348,349,350,352,354,355,356,358,359
08	341-1,345,346,347,348,349,350,352,354,355,356,359
10	341-3,345,346,347,348,349,350,352,354,355,356,359
11	346,346-1,347,348,349,350,353,359,360-3,011
12	346,346-1,347,348,349,350,353,359,011,360-2
13	346,346-1,347,348,349,350,353,359,011,360-2
14	346,346-1,347,348,349,350,353,359,011,360-2
15	346,346-1,347,348,349,350,353,359,011-1,360-2
16	346,346-1,347,348,349,350,353,359,011,360-2
17	346,346-1,347,348,349,350,353,359,360-3,011
18	346,346-1,347,348,349,350,353,359,011,360-2,360-3
19	346,346-1,347,348,349,350,353,360-3,011,361
20	346,346-1,347,348,349,350,353,360-3,011,362,363
21	346,346-1,347,348,349,350,351,353,360-2,011
22	346,347,348,349,350,353,351,360-3,011
23	347,348,349,350,353,011,360-2,362,364
24	347,348,349,350,353,011,360-2,362,365
25	347,348,349,350,353,011,360-2,368
26	347,348,349,350,353,011,360-2,362,363,366
27	347,348,349,350,353,360-3,011,367,369
28	346,347,348,349,350,353,360-3,011
29	346,347,348,349,350,351,353,360-3,011-2
30	346,346-1,347,348,349,350,353,358,011-2

329	Veniec	244512700
330	Satelit	204843100
331	Puzdro KU 1412	663243150
332	Koleso kuželové	244512200
333	Ložisko KU 40x30	663249037
334	Podložka	244511600
335	Podložka dištančná	244517000
336	Podložka	244517300
337	Podložka	244868901
338	Podložka	244868902
339	Kružok poistný FE 14	663111943
340	Ložisko 6008	663243024
341	Puzdro	244513600
342-X	Puzdro	20462960X
343	Puzdro KU 14x15	663243160
344-2	Rozperka	244508902
345	Podložka	244513300
346	Podložka s=0,2	244513400
346-1	Podložka s=0,3	244513401
347	Matica	244513500
348	Podložka	244538900
349	Kružok 3167 32x2	662732097
350	Zavlačka	663111756
351	Pružina TF 25x12,2x0,96x1,6	663152158
352	Závitkový hriadeľ	244512800
353	Závitkový hriadeľ	204867600
354	Zátka	244513700
355	Podložka dištančná	244832700
356	Podložka dištančná	244832800
357	Podložka upch. P21x20	662731060
358	Podložka	244519200
359	Pružina TF 25X12,2X0,7X1,6	663152071
360-2	Rozperka	244506902
360-3	Rozperka	244506903
361	Pružina TF 23X12,2X1,0	663152075
362	Podložka pre valcové pružiny	244891800
363	Pružina	644867100
364	PRUŽINA TL 3150X232X0480	663152189
365	PRUŽINA TL 2500X225X0530	663152191
366	RURKA VYMEDZOVACIA	204721300
367	PRUŽINA TL 3150X192X0500	663152190
368	PRUŽINA TL 2000X180X0530	663152192
369	Pružina 28X12,2X1,25 GR2	663152156

Poznámka: Dielce pre jednotlivé vyhotovenia závitovky sú rozpísané v hornej tabuľke ale nie sú všetky zobrazené.

013-xx Hriadel' s unášačom 224 5024 XX

List 1 z 3

XX	325-XX Unášač 244 5119 XX	326-11 Čap 244 5120 11	327 Kr. po 40	328 Pero 8x7x20	3XX-XX Výstupný hriadel'	Poznámky 1	Poznámky 2	
01	12	+	+	+	301	244 5393 00	L=243,5 2P 4zu30 ⁰	MO diera skrz Ø28
02	12	+	+	+	302	204 9243 00	L=180,6 2P, 2 zu14	T-C, koniec Ø30,3/17
03	12	+	+	+	303	244 5118 00	L=253,5 2P 4zu30 ⁰	MO diera skrz Ø28
04	-							
05	12	+	+	+	304	244 5371 00	L=181 2P 4zu30 ⁰	die skrz Ø28 koniec Ø30,3/17
06	12	+	+	+	305	244 5503 00	L=239,1 2P PØ25P8	MP plný
07	12	+	40,26, 32	+	306 307	244 6051 00 244 6052 00	L=247, MP-E L=262, Ø11 tyč	Základné vyhotovenie
08	-							
09	12	+	+	+	308	204 6140 00		Nemá výkres v systéme
10	-							
11	11	+	+	+	309	244 9468 00	L=243,5 4P 4zu30 ⁰	MO diera skrz Ø28
12	12	+	+	+	310	244 5392 00	L=253,5 2P, 2 zu14	MO-Ex T-C diera skrz Ø28
13	13	+	+	+	311-28	204 A013 28	L=250,5 3P DØ25P8	diera, plný kon MO 3.5, kr.je.
14	12	+	+	+	305-01	244 5503 01	L=239,1 2PPØ252P8	MP závora plný s M8 a 2P8
15	12	+	+	+	313	204 8578 00	L=234,6 2P PØ25P8	MP plný, závit M4 na konci
16	11	+	+	+	314-01	244 9942 01	L=253,5 4P, 4zu45 ⁰	MO-Ex T-C diera skrz Ø28
17	11	+	+	+	309-01	244 9468 01	L=253,5 4P 4zu30 ⁰	MO-Ex diera skrz Ø28
18	11	+	+	+	315	204 8551 00	L=243,5, 4P, T-C	01: L=253,5, 4P, T-C
19	12	+	+	+	316	204 9125 00	L=220,6 2P, Ø25P8	MP plný ,koniec Ø30,3/17
20	12	+	+	+	310-01	244 5392 01	L=243,5 2P, 2 zu14	MO T-C diera skrz Ø28
21	11	+	+	+	317	204 9306 00	L=296,5 4P, Ø20P6	P-1103/02
22	11	+	+	+	315-01	204 8551 01	L=253,5, 4P, T-C	03 L=180,7 4P T-C, Ø30/17 04 L=243,5 4P T-C MO
23	11	+	+	+	317-01	204 9306 01	L=233,7 4P, Ø20P6	P-1103/02, T-C, Ø30/17
24	11	+	+	+	315-04	204 8551 04	L=243,5 4P, Ø15P5	MO,T-C Ø15H8
25	11	+	+	+	302-01	204 9243 01	L=180,6 4P, 4xzub	MO, 4xzub, CPT, Ø30/17
26	11	+	+	+	315-03	204 8551 03	L=180,7 4P, Ø20P6	MO,P-1103/03T-E,CPTØ30/17
27								
28								
29								
30								
31	Tri drážky 13	+	+	+	311-00	204 A013 00	L=243,5 3P 4xzub	MO, 4x45 Rusko
32	Tri drážky 13	+	+	+	311-01	204 A013 01	L=253,5 3P 4xzub	MO-Ex, 4x45 Rusko
33	Tri drážky 13	+	+	+	311-02	204 A013 02	L=243,5 3P 4xzub	MO-MT, 4x30 Rusko
34	Tri drážky 13	+	+	+	311-03	204 A013 03	L=243,5 3P Ø20P6	MO Mapol
35	Tri drážky 13	+	+	+	311-04	204 A013 04	L=253,5 3P Ø20P6	MO-Ex Mapol
36	Tri drážky 13	+	+	+	311-05	204 A013 05	L=180,7 3P Ø20P6	MO, CPT Ø30,3/17
37	Tri drážky 13	+	+	+	311-06	204 A013 06	L=243,5 3P Ø15P5	MO
38	Tri drážky 13	+	+	+	311-09	204 A013 09	L=180,7 3P 2 zu14	MOCPT+Kotúč 204A64600
39	Tri drážky 13	+	+	+	311-10	204 A013 10	L=180,7 3P 4zu45 ⁰	MOCPT+Kotúč 204A64600
40	Tri drážky 13	+	+	+	311-11	204 A013 11	L=253,5 3P 4zu30 ⁰	MO,MT-Ex 4x30
41	Tri drážky 13	+	+	+	311-12	204 A013 12	L=239,1 3P PØ25P8	MP plný hriadel'
42	Tri drážky 13	+	+	+	311-13	204 A013 13	L=239,1 3P PØ20,9P8	MP plný hriadel' 2x pero P8
43	Tri drážky 13	+	+	+	311-14	204 A013 14	L=228,6 3P PØ25P8	MP, MPR CPT, c
44	Tri drážky 13	+	+	+	311-15	204 A013 15	L=180,7 3P 4zu30 ⁰	MO, MT CPT 4x30, Ø31/17
45	Tri drážky 13	+	+	+	311-16	204 A013 16	L=253,5 3P 2 zu14	MO-Ex drážka 14
46	Tri drážky 13	+	+	+	311-17	204 A013 17	L=243,5 3P 2 zu14	MO drážka 14
47	Tri drážky 13	+	+	+	311-18	204 A013 18	L=296,5 3P PØ20P6	Plný hriadel' 1103/02
48	Tri drážky 13	+	+	+	311-19	204 A013 19	L=233,7 3P PØ20P6	Plný hriael' 1103/02, Ø30,3/17
49	Tri drážky 13	+	+	+	311-20	204 A013 20	L=234,6 3P PØ25P8	Plný hr. MPR, OV
50	Tri drážky 13	+	+	+	311-21	204 A013 21	L=244,5 3P 4zu45 ⁰	MO 4x45 Rusko IP55
51	Tri drážky 13	+	+	+	311-22	204 A013 22	L=244,5 3P 4zu30 ⁰	MO MT 4x30 Rusko IP55
52	Tri drážky 13	+	+	+	311-25	204 A013 25	L=244,5 3P 2 zu14	MO drážka 14
53	Tri drážky 13	+	+	+	311-26	204 A013 26	L=240,5 3P DØ25P8	MO 3.5 D25 diera s perom 8
54	Tri drážky 13	+	+	+	311-27	204 A013 27	L=177,7 3P DØ25P8	MO3.5P,diera s P8, Ø30,3/17
55	Tri drážky 13	+	+	+	311-29	204 A013 29	L=180,7 3P D20x20	Diera 20x20, Ø30,3/17
56	Tri drážky 13	+	+	+	311-30	204 A013 30	L=253,5 3P D20x20	MO-Ex Diera 14x14
57	Tri drážky 13	+	+	+	311-31	204 A013 31	L=339,5 3P PØ30P8	MO Plný hriael'
58	Tri drážky 13	+	+	+	311-35	204 A013 35	Ø00-6,9-22,25-43	MO 25x25
59	Tri drážky 13	+	+	+	312	204 B093 00	L=214 3P DØ25P8	diera, plný kon MO 3.5, kr.je.
60	Tri drážky 13	+	+	+	311-36	204 A013 36	L=217,5 3P DØ20P6	Plný hr. MO 20/6 krok.j.
61	Tri drážky 13	+	+	+	311-42	204 A013 42	L=244,5 3P 2 zu14	MO vrtanie Ø29,2, dráž. 14
62	Tri drážky 13	+	+	+	311-43	204 A013 43	L=243,5 3P DØ22P6	MODiera ØD22, 2P6 Ma
63	Tri drážky 13	+	+	+	311-41	204 A013 41	L=293,5 3P 4zu30 ⁰	MO,MT 4x30, krok.j.
64	Tri drážky 13	+	+	+	311-40	204 A013 40	L=293,5 3P 4zu45 ⁰	MO,MT 4x45 krok.j.
99	Tri drážky 13	+	+	+	-	Bez hriadela		MO 3.3

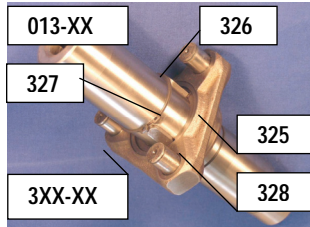

301 (L=243,5 2xP 4zu30°)

302 (L=180,6; 2xP; TVAR C)

303 (L=253,5 2xP 4zu30°)

--	--	--	--

304 (L=181 2P 4zu30°) 305 (L=239,1 2P PØ25P8) 306,307(L=247, MP-F, L=262, Ø11 tvč) 308(.....)

--	--	--	--

309 (L=243,5 4P 4zu30°)

310(L=253,5 2P, 2 zu14)

311-28 (L=250,5 3P DØ25P8)

305-01 (L=239,1 2PPØ252P8)

--	--	--	--

313 (L=234,6 2P PØ25P8)

314-01(L=253,5 4P, 4zu45°)

309-01(L=253,5 4P 4zu30°)

315 (L=243,5, 4P, T-C)

--	--	--	--

316 (L=220,6 2P, Ø25P8)

310-01(L=243,5 2P, 2 zu14)

317(L=296,5 4P, Ø20P6)

315-01 (L=253,5, 4P, T-C)



317-01 (L=233,7 4P, Ø20P6)

315-04 (L=243,5 4P, Ø15P5)

302-01 (L=180,6 4P, 4xzub)

315-03 (L=180,7 4P, Ø20P6)

--	--	--	--



311-00 (L=243,5 3P 4xzub)

311-01 (L=253,5 3P 4xzub)

311-02 (L=243,5 3P 4xzub)

311-03 (L=243,5 3P Ø20P6)

--	--	--	--

311-04 (L=253,5 3P Ø20P6)

311-05 (L=180,7 3P Ø20P6)

311-06 (L=243,5 3P Ø15P5)

311-09 (L=180,7 3P 2 zu14)

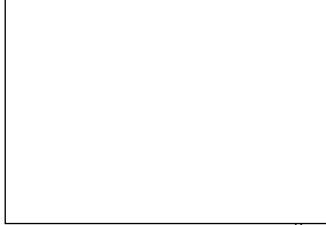
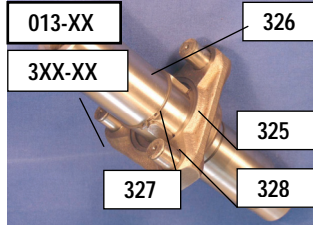

311-10 (L=180,7 3P 4zu45⁰) 311-11 (L=253,5 3P 4zu30⁰) 311-12 (L=239,1 3P PØ25P8)

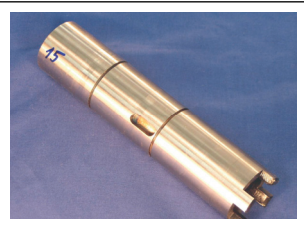

311-13 (L=239,1 3P PØ20,9P8) 311-14 (L=228,6 3P PØ25P8) 311-15 (L=180,7 3P 4zu30⁰) 311-16 (L=253,5 3P 2 zu14)



311-17 (L=243,5 3P 2 zu14) 311-18(L=296,5 3P PØ20P6) 311-19(L=233,7 3P PØ20P6) 311-20 (L=234,6 3P PØ25P8)

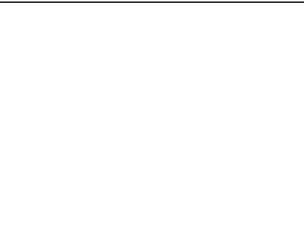
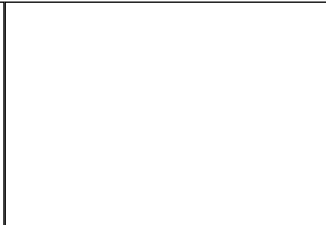

311-21 (L=244,5 3P 4zu45⁰) 311-22 (L=244,5 3P 4zu30⁰) 311-25(L=244,5 3P 2 zu14) 311-26 (L=240,5 3P DØ25P8)

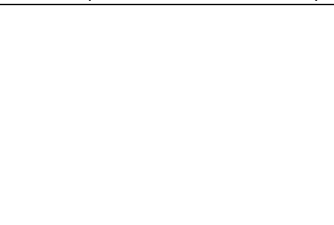
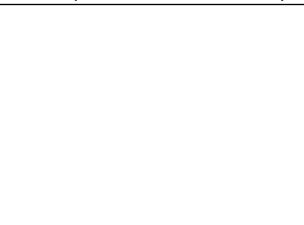

311-27 (L=177,7 3P DØ25P8) 311-29 (L=180,7 3P D20x20) 311-30(L=253,5 3P D20x20) 311-31 (L=339,5 3P PØ30P8)

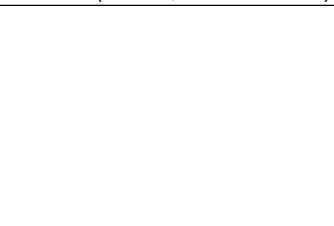
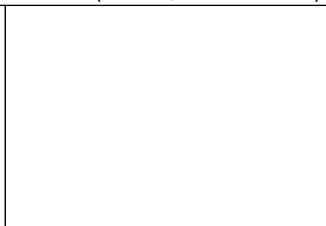
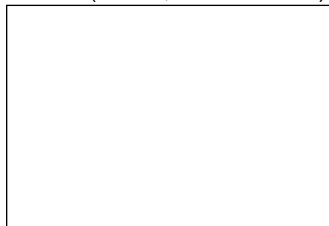

311-35 (MO 25x25) 312 (L=214 3P DØ25P8) 311-36(L=217,5 3P DØ20P6) 311-42 (L=244,5 3P 2 zu14)

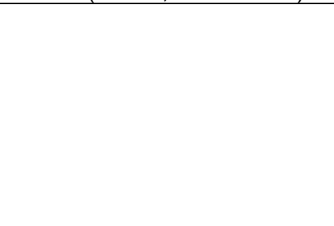
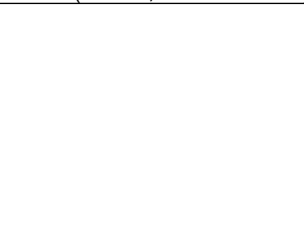
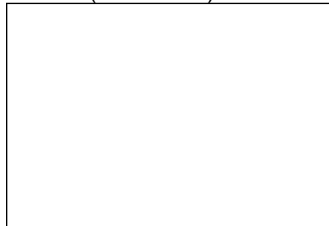

311-43 (L=243,5 3P DØ22P6) 311-41 (L=293,5 3P 4zu30⁰) 311-40 (L=293,5 3P 4zu45⁰) (.....)

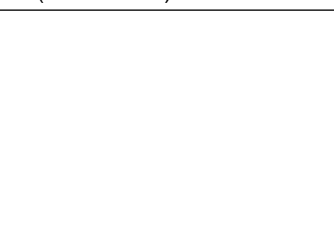
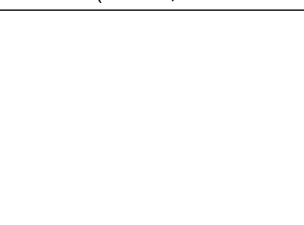
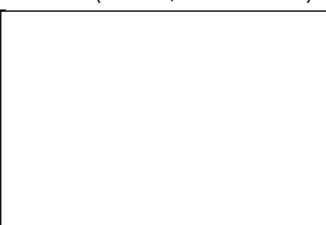
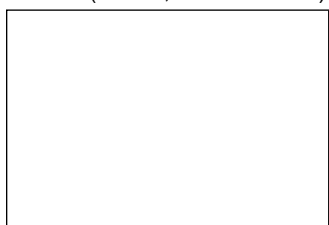

(.....)

(.....)

(.....)

(.....)

043 Predlohový prevod ES MTR Variant

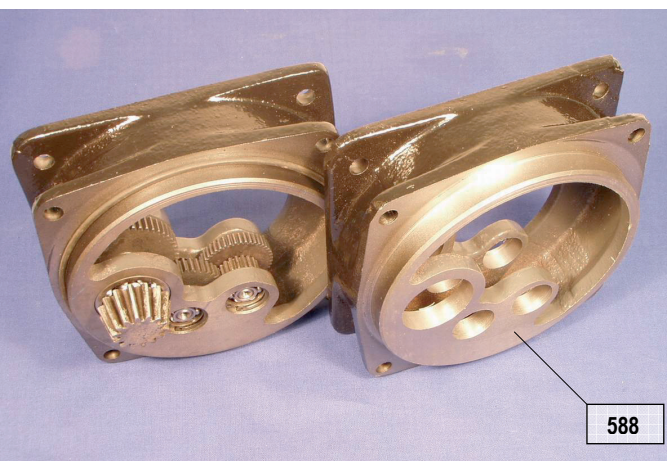
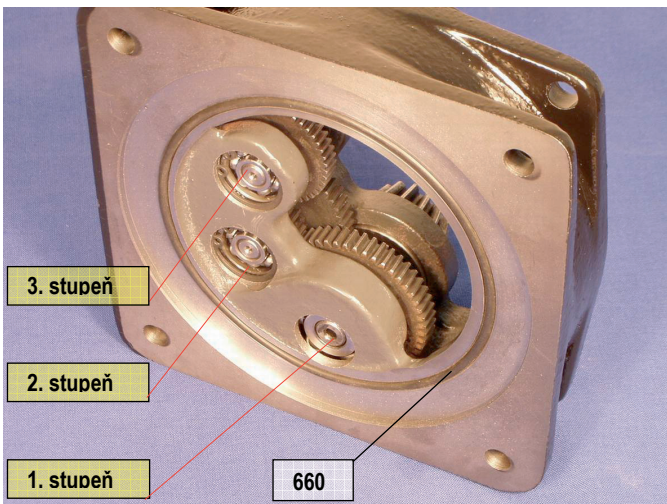
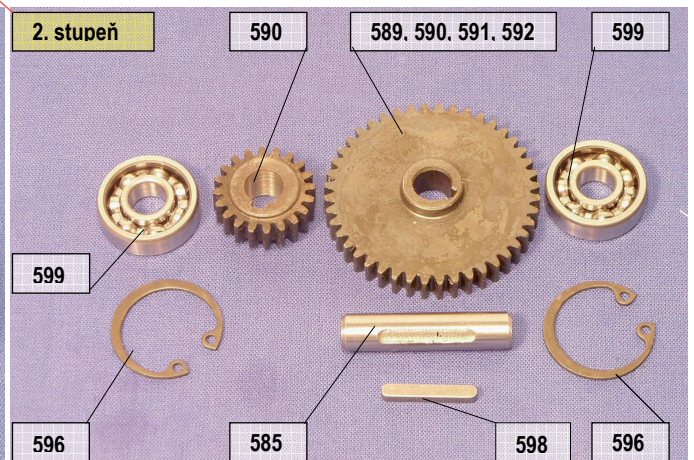
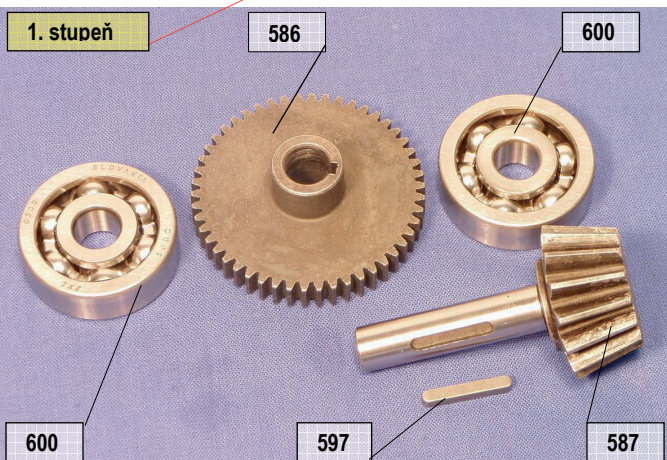
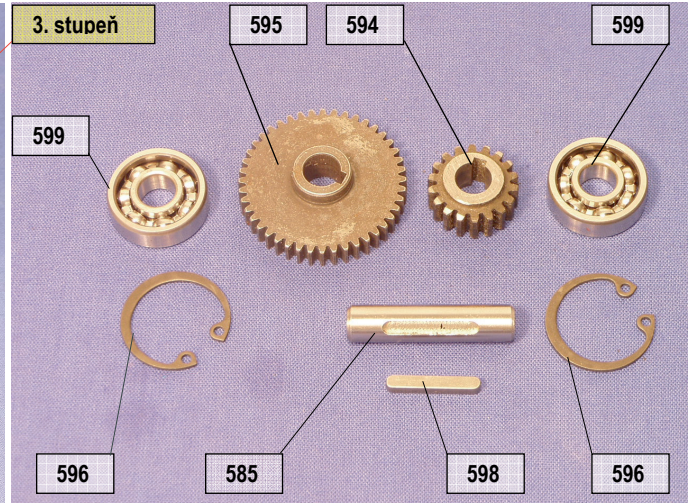
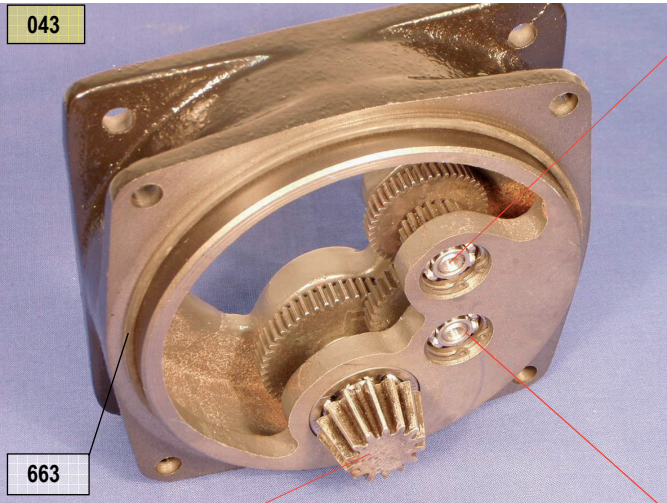

Poz.	Názov	PNm	Poznámky
043-01	Skriňa predlohová pre 32 mm/min	224519901	1+2+3 stup. N2
043-02	Skriňa predlohová pre 32 mm/min	224519902	1+2+3 stup. T2
043-03	Skriňa predlohová pre 50 mm/min	224519903	1+2 stupeň N2
043-04	Skriňa predlohová pre 50 mm/min	224519904	1+2 stupeň T2
043-05	Skriňa predlohová pre 63 mm/min	224519905	1+2 stupeň N2
043-06	Skriňa predlohová pre 63 mm/min	224519906	1+2 stupeň T2
043-07	Skriňa predlohová pre 100 mm/min	224519907	1+2 stupeň N2
043-08	Skriňa predlohová pre 100 mm/min	224519908	1+2 stupeň T2
043-X	Skriňa predlohová pre 160 mm/min	22451990X	iba 1 stupeň
585	HRIADEL	244528300	
586	KOLESO OZUBENE	244533200	
587	PASTOROK	244533400	
588-1	MEDZIPRIRUBA	244561401	01- N2, 02 – T2
589	KOLESO OZUBENE	244563200	32 mm/min
590	KOLESO OZUBENE	244563300	50 mm/min
591	KOLESO OZUBENE	244563400	63 mm/min
592	KOLESO OZUBENE	244563500	100 mm/min
593	PASTOROK	244567300	
594	PASTOROK	244529100	
595	KOLESO OZUBENE	244563100	
596	KRUZOK POIST FE 22	663112245	
597	PERO 3X3X18	663152072	
598	PERO 3X3X20	663152073	
599	LOZISKO 608	663243030	
600	LOZISKO 6300	663249040	
660	KRUZOK 100X3	662732117	
663	KRUZOK 125X3	662732115	

044, 047 Priamočiare ústrojenstva

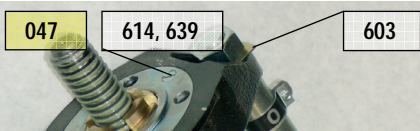

048-XX	Spojka	PNm Spojky	Skrut.	Stu.
01	M20x1,5	244873800	049-02	s=3
02	M16x1,5	244873900		
03	M10x1	244874000		
04	M20x1,5	244878500		
05	M16x1,5	244739900		
06	M10x1	244740000		
07	M20x1,5	244873800	049-01	s=5
08	M16x1,5	244873900		
09	M10x1	244874000		
10	M20x1,5	244878500		
11	M16x1,5	244739900		
12	M10x1	244740000		

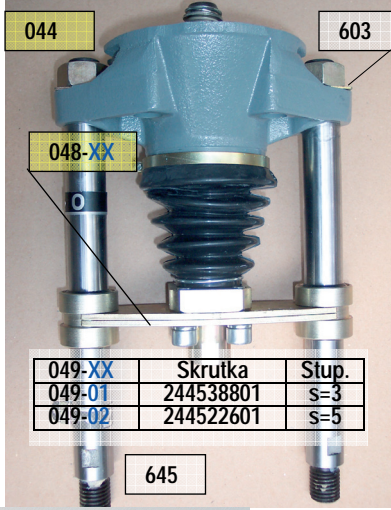

049-XX	Skrutka	Stup.
049-01	244538801	s=3
049-02	244522601	s=5

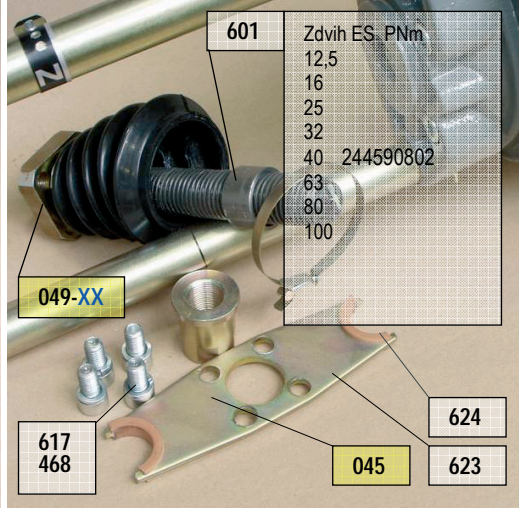

Zdvih ES. PNm	
12,5	
16	
25	
32	
40	244590802
63	
80	
100	

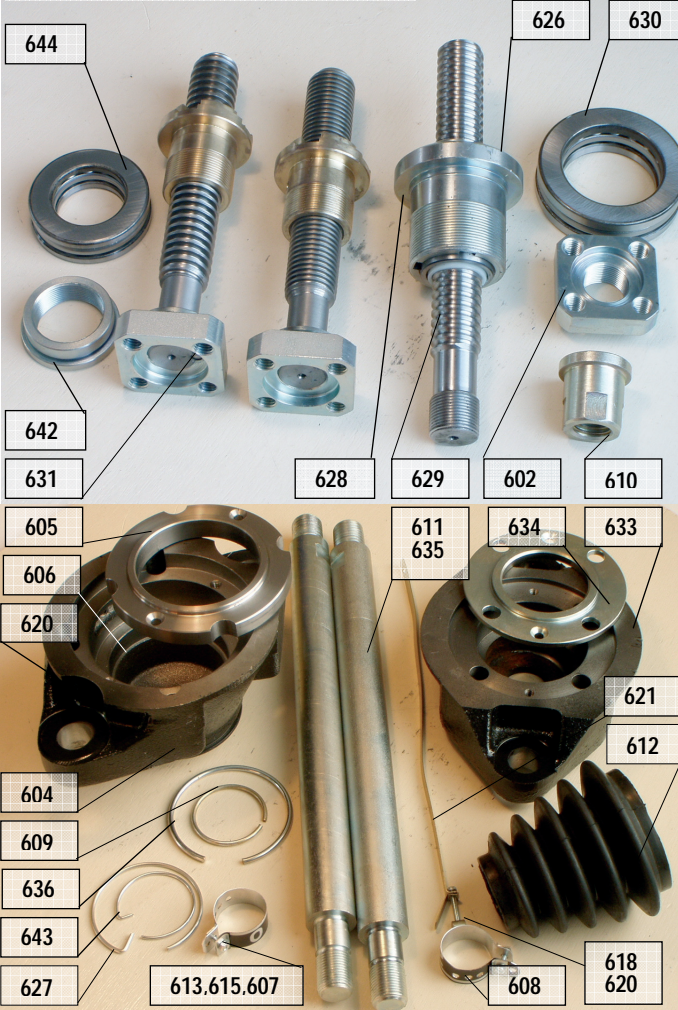

Poz.	Názov	PNm	Poznámky
044-X	PRIAM. USTROJ. S GULIC. SKRUT.	2245120XX	s GS K 25x5
045	TELESO VODIACE	224504600	
046	SKRUTKA GULICKOVA S MATICOU	224527800	
047-X	PRIAM. USTROJ. S TRAP. SKRUT.	2245043XX	stup. 3 resp 5
048-X	SKRUTKA SO SPOJKOU	224A1050X	stup. 3 resp 5
049-X	SKRUTKA S OBJIMKOU	224A1040X	stup. 3 resp 5
050-X	MATICA S LOZISKOM	22450450X	stup. 3 resp 5
389	PODLOZKA DISTANCNA	244831900	pre Tr skrut.
468	PODLOZKA FE 10-A2	663117455	
537	PODLOZKA DISTANCNA	244853900	pre Tr skrut.
601	TRUBKA DORAZOVA	24459080X	podľa zdvihu ES
602-X	OBJIMKA-SO ZAVITOM M24	24452310X	
603	PODLOZKA	244523800	
604-X	TELESO PRIAM. USTROJENSTVA	24454730X	pre GS
605	KRUZOK OPERNY	244547400	pre GS
606	PODLOZKA 2	244548000	pod ložisko
607	PRILOZKA	244745200	
608-1	STITOK	244854301	
608-2	STITOK	244854302	
609	KRUZOK FE 40	663112047	
610-3	SPOJKA M 20 X 1,5	204971403	špec. závit
611	STLPIK	244945400	podľa armat.
612-1	MANZETA KRYCIA	644854001	
613	SKRUTKA FE M 3X10-ZN	663111166	
614	SKRUTKA FE M 5X16-ZN	663111313	
615	MATICA FE M 3-ZN-8.8	663111537	
616	MATICA FE M 18X1,5-ZN-8.8	663111568	
617	SKRUTKA M 10X20-A2-70	663117190	
618	SKRUTKA FE M 3X20-ZN	663111172	
619	PERO 5X5X16	663152030	pôvod. vyhot.
620	HLAVICA KM 8X1	663194012	mazacia
621	PASIK STAHOVACI	204675904	
622	VALCEK	204676000	
623	PLECH VODIACI	244523200	
624	LOZISKO	244523300	
625	MATICA	244547500	
626-1	PUZDRO GUL. MATICE	244547601	
627	KRUZOK FE 54	663112587	
628	PODLOZKA 1	244547900	pod ložisko
629-1	SKRUTKA GUL. K 25X5	624798301	
630	LOZISKO 51210	663243051	
631	KOLIK FE 6X16	663111501	
632	KRUZOK	244531800	vod. spoj. k arm
633	TELESO PRIAMOCIAREHO USTR.	244520701	pre Tr skrutku
634	KRUZOK OPERNY	244520800	
635	STLPOK	244522000	pre Tr skrutku
636	KRUZOK FE 65	663112048	
637	SKRUTKA FE M 5X10-ZN	663111311	pre Tr skrutku
638	SKRUTKA-ZAVIT TR26X3 LAVY	244522601	S=3
639	SKRUTKA FE M 5X10-ZN	663111311	pre Tr skrutku
640	MATICA	244522300	pre Tr s=3
641	MATICA	244539100	pre Tr s=5
642	MATICA	244522500	pre Tr skrutku
643	KRUZOK FE D 39 02 2927	244853700	pre Tr skrutku
644	LOZISKO 51207	663243027	pre Tr skrutku
645	PRIRUBA PRIAMOCIAREHO USTROJ.	244754100	podľa armatury

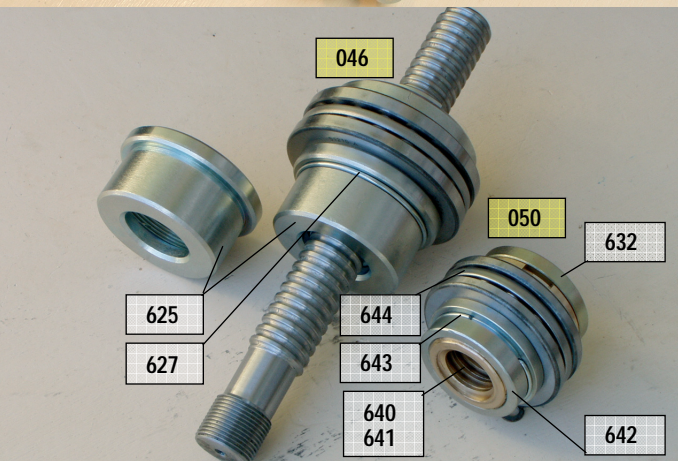

051-T Elektrický servopohon MTR Variant

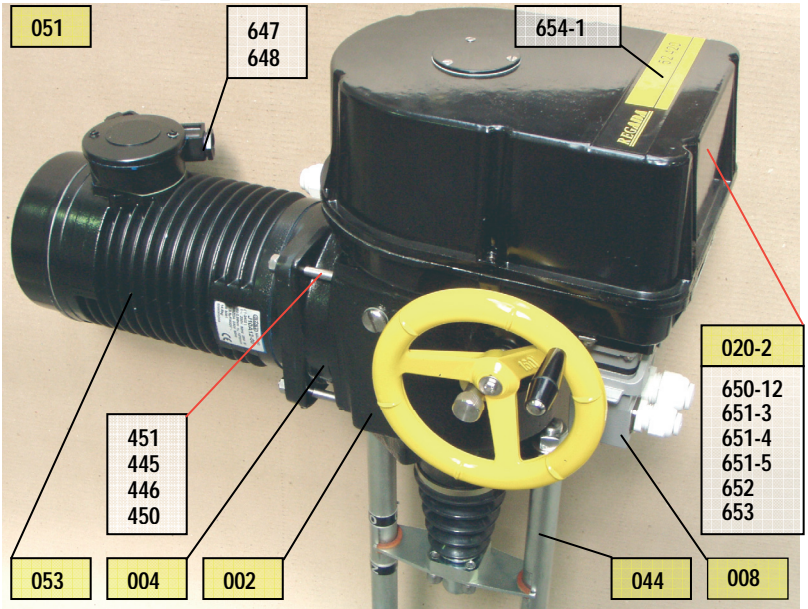
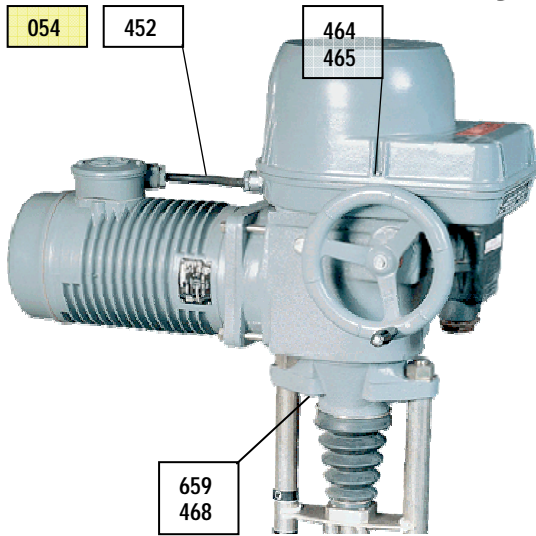

654-1	STITOK REGADA 52 420	644596001
659	SKRUTKA M 10X55-A2-70	663117191
664	ODPOR ZRAZACI HSA 25 W 33 OHM	663710864

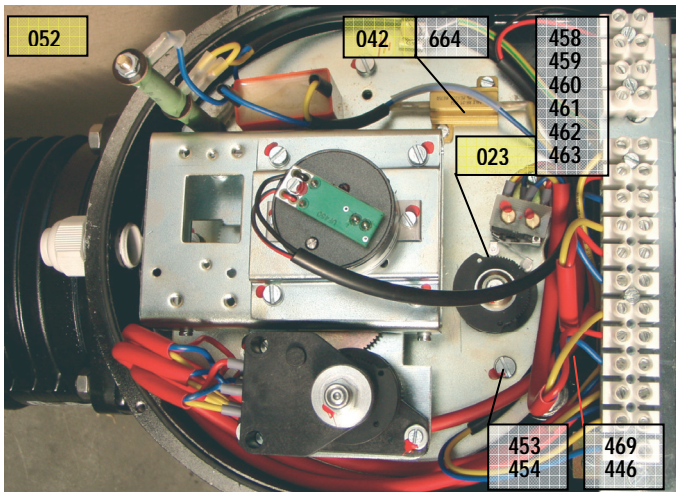
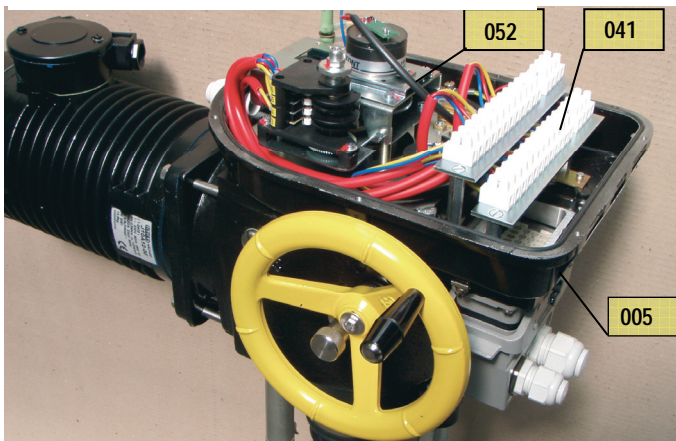

Poz	Názov	PNm	Poznámky
002-XX	SILOVÝ PREVOD	2245640XX	špec. text.
004-X	PREVOD PREDLOHOVÝ	22452930X	špec. text.
005-X	SKRINA RIADIACA	224A2110X	špec. text.
007-X	MOTOR-UPRAVA	22452390X	špec. text.
008-X	ZOSTAVA KONEKTOROV-HARTING	224A0020X	špec. text.
020-X	KRYT RIADIACEJ SKRINE	22457220X	špec. text.
023	MOMENTOVÝ OVLADAC	XXXXXXX	fikt. zostava
041-X	SVORKOVNICA ZOSTAVA-S	224A0690X	špec. text.
044-X	USTROJENSTVO PRIAMOCIARE	22451200X	špec. text.
051-XX	EL. SERVOPOHON MTR VARIANT	2247630XX	špec. text.
052-XX	OVLADACIA DOSKA MTR	2247655XX	špec. text.
053-X	ELEKTROMOTOR-UPRAVA	22451920X	špec. text.
054-X	ES MTR 52 420 MODACT VARIANT	224520400	pôvodná konštruk.
430-X	PRIRUBA-UPRAVA	20496150X	
431-X	KRYT	24457970X	
432	TESNENIE	244742500	
433	KRUZOK TESNIACI	244914700	
434	KRUZOK 9X5	662731105	
435	KRUZOK 140X3	662731115	
436	KRUZOK GUFERO	662735040	
437	PODLOZKA FE 5,3-ZN	663111691	
438	MOTOR J9 A10-00 50 HZ 230V 16W	663592071	bez úpravy
445	MATICA FE 8-A2	663112950	
446	PODLOZKA FE M 8-A2	663117454	
450	VLOZKA STREDIACA	244572800	
451-1	SVORNIK M8x60	244930301	
452	VODIC H07RN-F 5G 1MM	663414732	
453	SKRUTKA FE M 5X10-ZN	663111207	
454	PODLOZKA FE 5-ZN	663111732	
458	KRUZOK	204703300	
459	PODLOZKA	204703200	
460	DISTANČNY KRUZOK MJ	604703100	
461	VACKA	604746100	
462	SKRUTKA FE M 4X8-ZN-8.8	663111010	
463	PODLOZKA FE 4,3-ZN	663111699	
464	SKRUTKA FE M 4X16-ZN	663111193	
465	PODLOZKA FE 4-ZN	663111731	
468	PODLOZKA FE 10-A2	663117455	
469	SKRUTKA FE M 8X20-ZN-8.8	663111085	upev. riad. skrine
645	MOTOR J10 A12-00 50 HZ 230V 25W	663592072	bez úpravy
646	KRUZOK FE 15	663112514	
647	TES. PODLOZKA P 16 STN 370189.50	663457020	
648	ZÁSLEPKA BIMED PG 16 OBJ. Č. BBS 15	663457019	
649	PASTOROK (podia ovládacej rýchlosti)	244563X00	podľa ovl. rýchli.
650-12	KRYT RIAD. SKRINE	204606212	
651-3	SCHEMA ZAPOJENIA Z 298 spinače	244570403	-4 Z 279A, -5 Z296
652	SCHEMA ZAPOJENIA Z 6A B2	204976400	
653	SCHEMA ZAPOJENIA Z 269A B3	204976600	

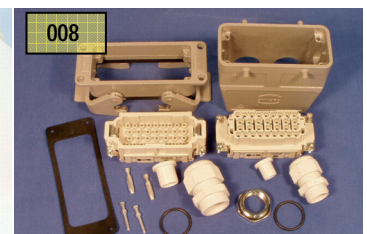
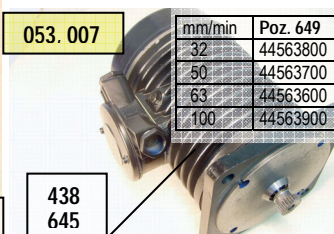

mm/min	Poz. 649
32	44563800
50	44563700
63	44563600
100	44563900

052-T Ovládacia doska ES MTR

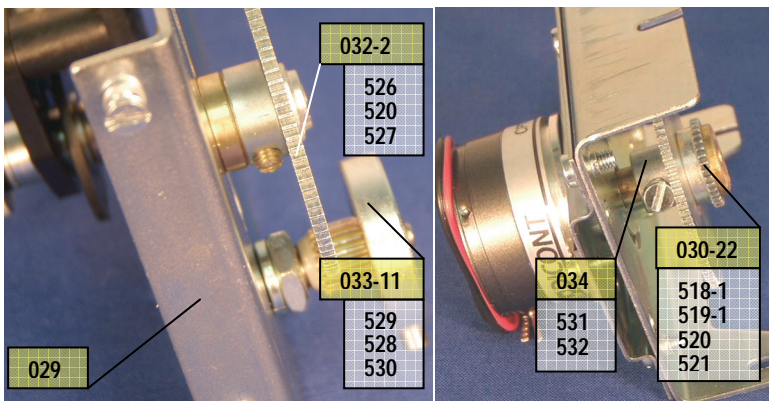
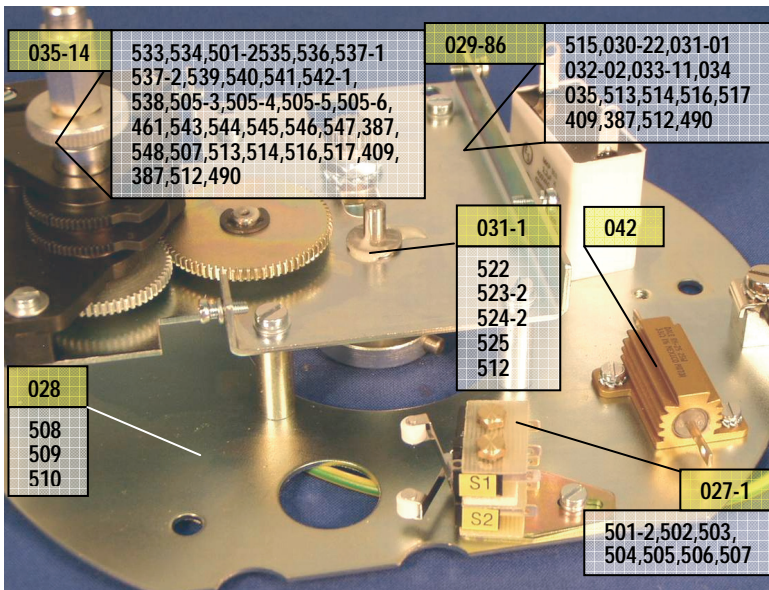
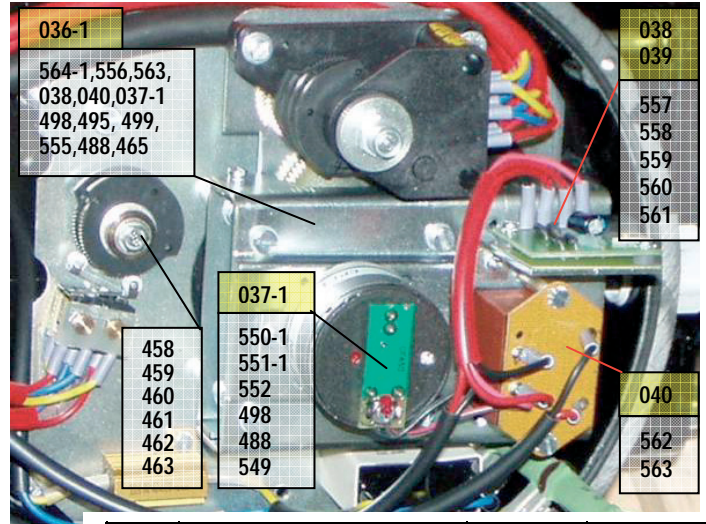
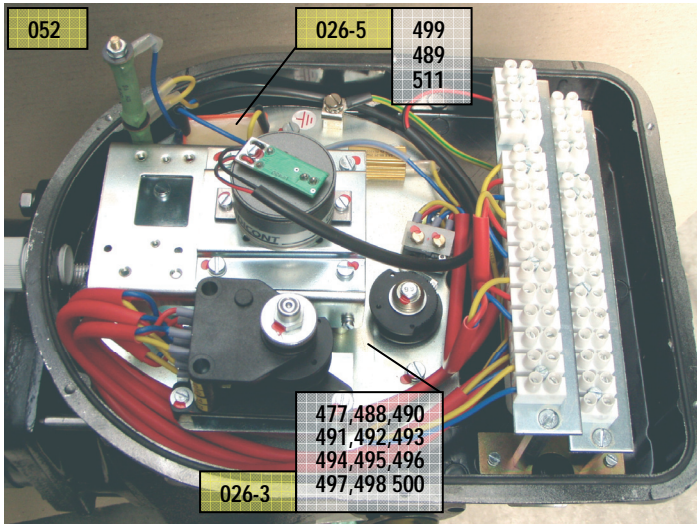

Poz	Názov	PNm	Poznámky
052-XX	OVLADACIA DOSKA 52 420 S CPT 1	224765506	špec. text.
026-3	OVLADACIA DOSKA-ZAKLADNA DOSKA	224745603	
026-5	OVLADACIA DOSKA-KONDENZATOR	224745604	
027-1	MOMENTOVE SPINACE	224744801	
028	ZAKLADNA DOSKA SO STLPIKMI	224745800	
029-XX	ZOSTAVA KOTEVNEJ DOSKY 52 420	224745736	špec. text.
030-XX	ZOSTAVA OZUB.KOLESA Z 45	2245110XX	špec. text.
031-XX	KOTEVNA DOSKA_S CAPMI	22451110X	špec. text.
032-XX	ZOSTAVA_OZUB_KOLESA	22451120X	špec. text.
033-XX	KOTUC_S_PASTORKOM	2245113XX	špec. text.
034	OBJIMKA_SO_SKRUT.	224522000	
035-XX	JEDNOTKA P-S	2247155XX	špec. text.
036-X	UPIN_DOSKA_S_KAP_VYS_CPT_1	224758300	špec. text.
037-X	NOSNIK_S_VYSIELACOM	22475820X	
038	USMERNOVAC	224741300	
039	ZDROJ 24V	228352600	
040	TRANSFORMATOR	224747700	
042	ZRAZACI ODPOR S VODICMI	224768900	
387	KRUZOK FE 5	663112049	
409	KRUZOK FE 3,2	663111720	
458	KRUZOK	204703300	
459	PODLOZKA	204703200	
460	DISTANCNY KRUZOK MJ	604703100	
461	VACKA	604746100	
462	SKRUTKA FE M 4X8-ZN-8.8	663111010	
463	PODLOZKA FE 4,3-ZN	663111699	
477	SKRUTKA MS M 5X10	663118109	
488	PODLOZKA FE 3-ZN	663111729	
489	PODLOZKA FE 4,3-ZN	663112246	
490	PODLOZKA FE 3,2-ZN	663112310	
491	PODLOZKA FE 3,2-ZN	663111740	
492	PODLOZKA	204784200	
493	SVORNIK	244569200	
494	PODLOZKA IZOLACNA	244805600	
495	SKRUTKA FE M 3X8-ZN	663111163	
496	STITOK	644601262	
497	ODPOR TR 616 12K K	663711007	
498	SKRUTKA FE M 3X6 ZN TVAR A	663111160	
499	SKRUTKA FE M 4X8-ZN	663111188	
500	PODLOZKA FE 5,3	663111704	
501-2	PODLOZKA	204703602	
502	DOSKA DISTANCNA	204707000	
503	SKRUTKA	204743800	

Poz	Názov	PNm	Poz.	Poz	Názov	PNm	Pozn.	Poz	Názov	PNm	Pozn.
504	DOSKA	204785800	text	524-X	ČAP STREDIACI	24454600X		544	MATICA FE M 3-ZN	663111539	
505-X	STITOK OZNAC. MSP	60468090X		525	PODLOZKA FE 8-ZN	663111734		545	PODLOZKA FE 6,4-ZN	663111692	
506	PODLOZKA B FE 2,2	663111686		526	NABOJ	244546200		546	KRUZOK FE 6	663111723	
507	MIKROSPINAC DB 6G-B1 RB	664051220		527	SKRUTKA FE M 4X8	663111364		547	KOLIK FE 2X12	663111967	
508	STLPIK ZEMNENIA	204784100		528	KOTUC STREDIACI	244546400		548	PRUZINA 12.5X6.2X0.5X0.85	663152112	
509	DOSKA	204786800		529	PASTOROK A 120°	204912800		549	VYSIELAC KAPACIT CPT 1/AV	664051781	
510	STLPIK	244547000		530	KOLIK FE 4X10	663111484		550-X	NOSNIK	24454810X	text
511	KONDENZATOR MKP 353 2U2/K	663540275		531	OBJIMKA	244565100		551-X	PUZDRO	24454830X	text
512	MATICA FE M 8X1-ZN	663112289		532	SKRUTKA FE M 4X6-ZN	663111839		552	PRICHYTKA	244949400	
513	PUZDRO	244545000		533	MATICA RYHOVANA M6	204660000		553	DOSKA UPINACIA	204828700	
514	KOLESO PRENOSOVE	244545300		534	PODLOZKA TRECIA	204661200		554-X	STLPIK DISTANCNY IND.VYS	20477640X	text
515	PASTOROK S OSKOU C-120°	204913200		535	HRIADEL J.P-S	204709300		555	PODLOZKA FE 3,2-ZN	663111710	
516	SKRUTKA FE M 3X14-ZN	663111168		536	MATICA	204709400		556	PODLOZKA	204786300	
517	PODLOZKA FE 8,4	663111715		537	PODLOZKA DISTANCNA	244853900		557	NOSNIK SP 1-IND.VYS	204776100	
518-X	OZUBENE KOLO.	20478670X		538-X	PODLOZKA DISTANCNA	20470950X	text	558	DOSKA IZOLACNA SP-OVL.	204776200	
519-X	PUZDRO	24454660X		539-X	UZAVER JPS	20470970X	text	559	STLPIK DISTANCNY IND.VYS.	204776300	
520	KOLESO OZUBENE	244555700		540	TYCKA MSP	204709800		560	SKRUTKA FE M 2,5X8 ZN	663111156	
521	KOLIK FE 2X6	663111453		541	KOLESO /160°/	204715600		561	PODLOZKA FE 2,7-ZN	663112747	
522	DOSKA KOTEVNA	204786600		055-1	KOSTRA JPS	224716501		562	DOSKA S PAJACIMI OKAMI	224747500	
523	CAP OZUB.KOLESA	244545902		543	SKRUTKA FE M 3X22-ZN	663111173		563	TRANSFOR MYRRA 1X18V	664031156	