

REGADA s. r. o., Strojnícka 7, Prešov

Katalóg náhradných dielov

Typ MPR Variant, t.č. 52 220

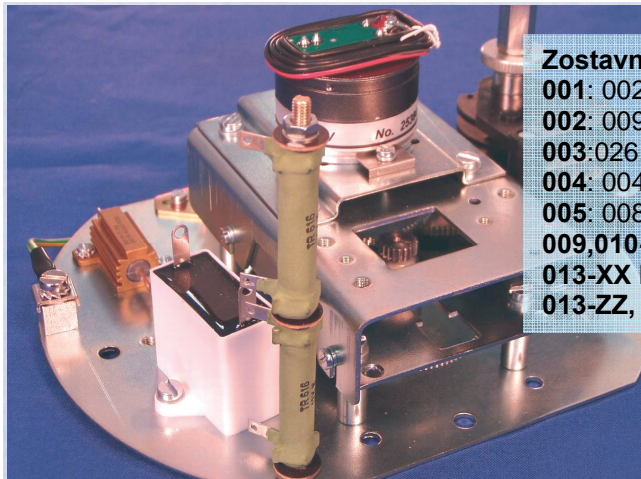

Zostavné diely podľa listov:

001: 002,003,004,005,006,007,008,020,021,022,023,024

002: 009,010,012,016,017,018,019

003: 026,027,028,029,030,031,032,033,034,035,036,037,038,039,040,042

004: 004,056,057,058

005: 008,025,041

009,010-21: 011,011-1,011-2,013,014-1,015

013-XX list 1: 013-01 až 013-99

013-ZZ, 3XX-XX list 2: 301 až 311-09

Vydanie 04/2008

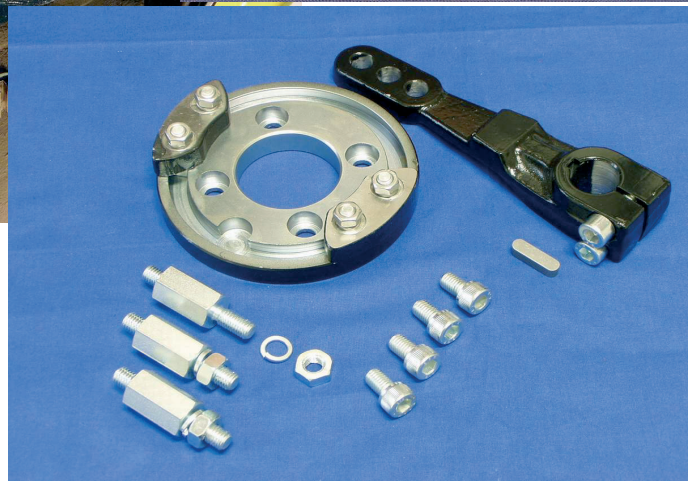
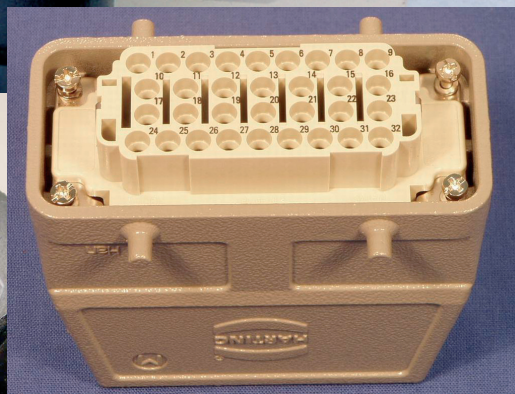
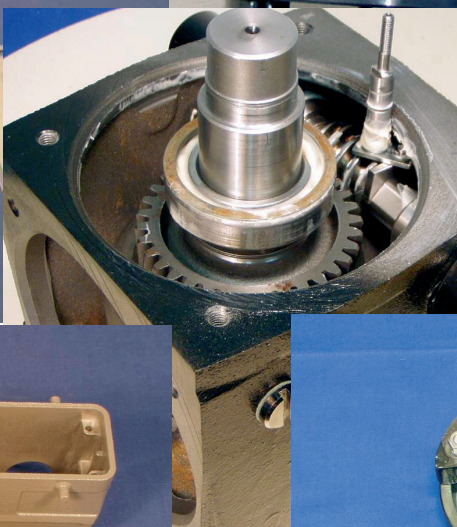
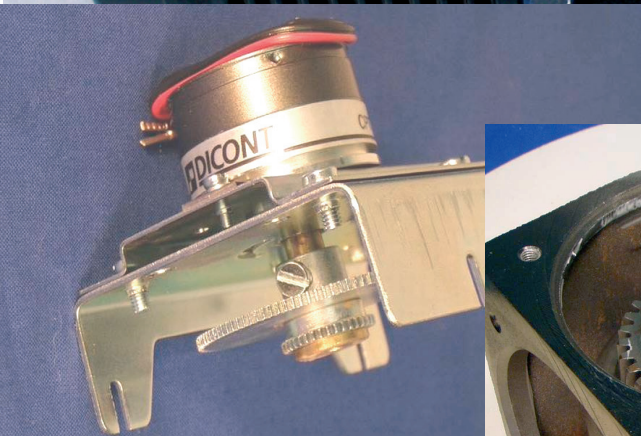
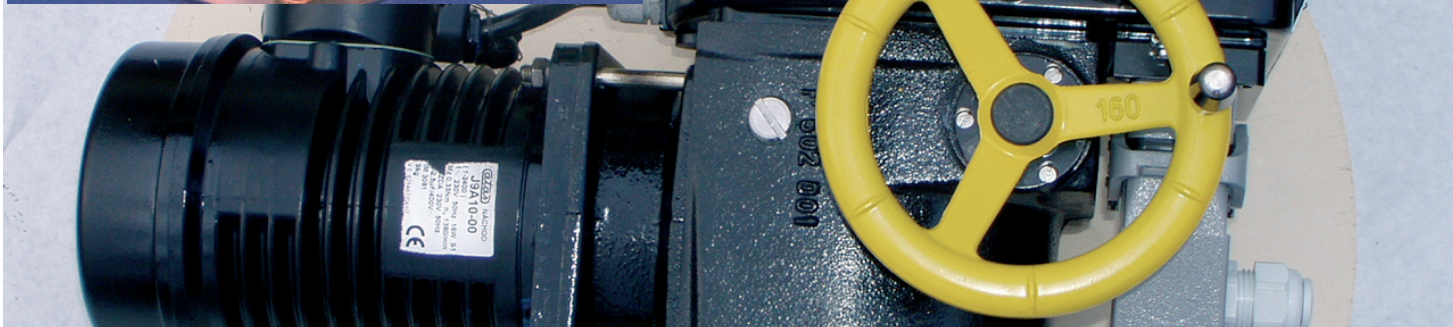

001-P Elektrický servopohon MPR Variant

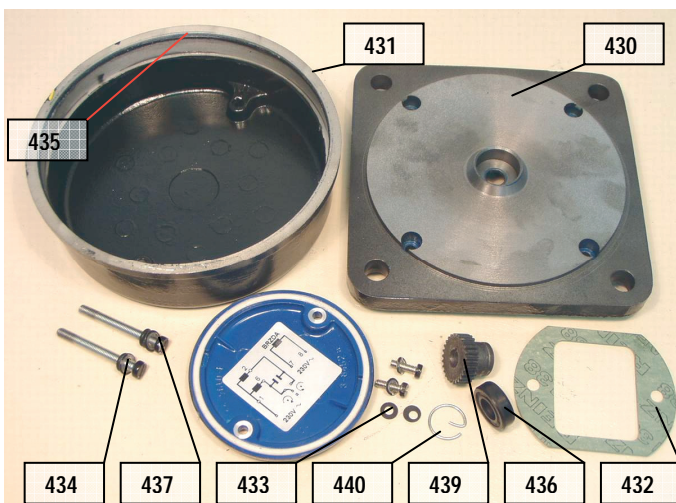
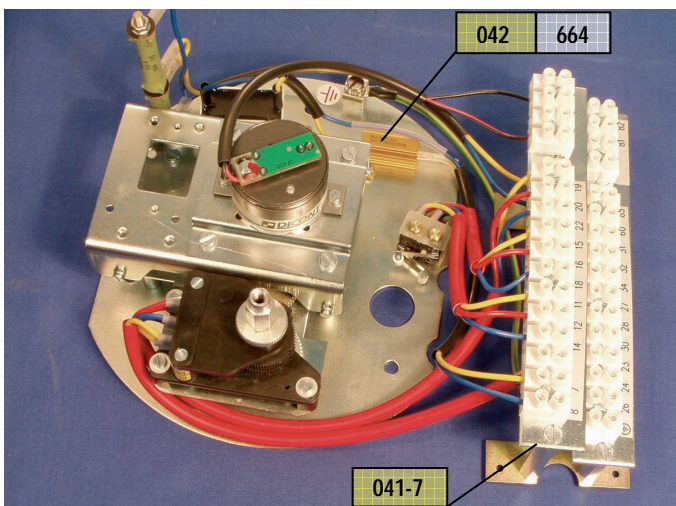
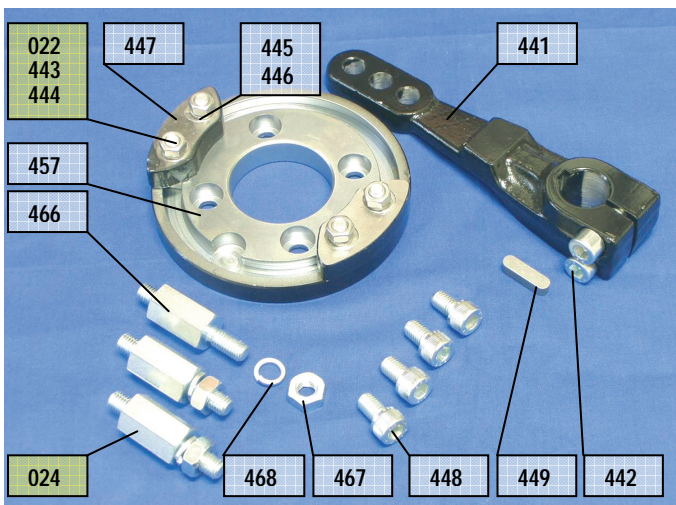
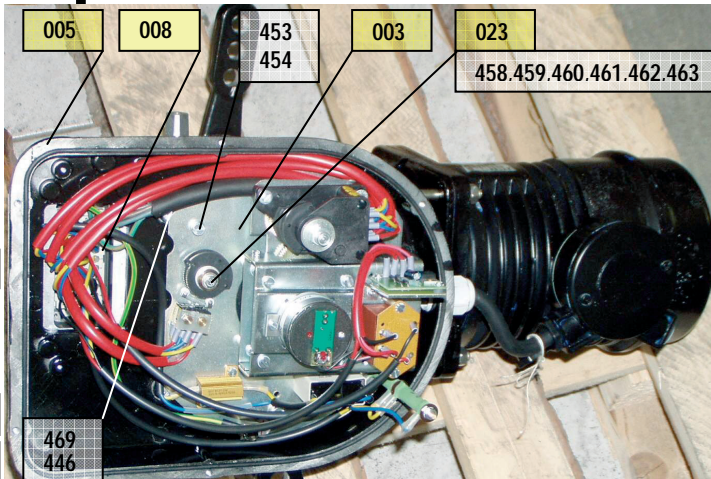
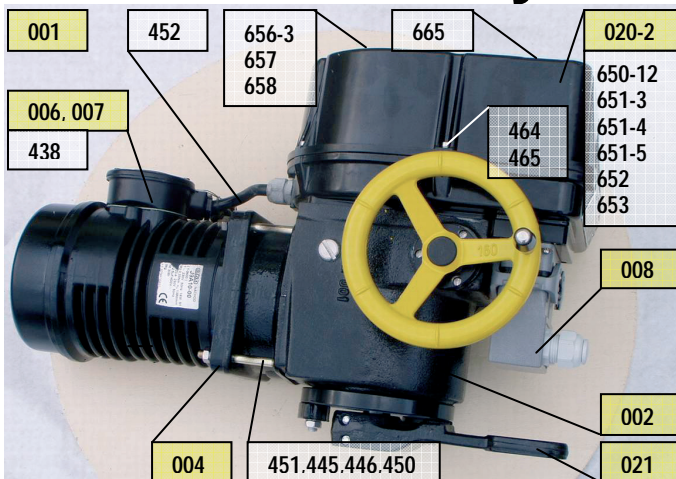

Poz	Názov	PNm	Poznámky
001-XX	EL. SERVOPOHON MPR VARIANT	2245258XX	špec. text.
002-XX	SILOVY PŘEVOD	2245640XX	špec. text.
003-XX	OVLADACIA DOSKA	2247445XX	špec. text.
004-X	PŘEVOD PŘEDLOHOVY	22452930X	špec. text.
005-X	SKRINA RIADIACA	224A2110X	špec. text.
006-X	ELEKTROMOTOR-UPRAVA	22452210X	špec. text.
007-X	MOTOR-UPRAVA	22452390X	špec. text.
008-X	ZOSTAVA KONEKTOROV-HARTING	224A0020X	špec. text.
020-X	KRYT RIADIACEJ SKRINE	22457220X	špec. text.
021-1	PAKA ZOSTAVA	224819001	
022	SKRUTKA ZOSTAVA	224818900	
023	MOMENTOVY OVLADAC	XXXXXXXXX	fikt. zostava
024	SVORNIK DLHY	224890101	
430	PŘIRUBA-UPRAVA	204961500	
041-X	SVORKOVNICA ZOSTAVA-S	224A0690X	špec. text.
042	ZRAZACI ODPOR S VODICMI	224768900	
431	KRYT	244579700	
432	TESNENIE	244742500	
433	KRUZOK TESNIACI	244914700	
434	KRUZOK 9X5	662731105	
435	KRUZOK 140X3	662731115	
436	KRUZOK GUFERO	662735040	
437	PODLOZKA FE 5,3-ZN	663111691	
438	MOTOR J9 A10-00 50 HZ 230V 16W	663592071	bez úpravy
439	PASTOROK	244593000	
440	KOLIK FE 3X12	663111755	
441	PAKA	244870901	
442	SKRUTKA FE M 10X40-ZN-8.8	663111410	
443	SVORNIK	244916000	
444	KAMEN	244870500	
445	MATICA FE 8-A2	663112950	
446	PODLOZKA FE M 8-A2	663117454	
447-1	ZARAZKA	244870701	
448	SKRUTKA FE M 10X16-ZN-8.8	663111676	
449	PERO 8X7X28	663152046	
450	VLOZKA STREDIACA	244572800	
451	SVORNIK	244930300	
452	VODIC H07RN-F 5G 1MM	663414732	
453	SKRUTKA FE M 5X10-ZN	663111207	
454	PODLOZKA FE 5-ZN	663111732	
457	PŘIRUBA	244870400	
458	KRUZOK	204703300	
459	PODLOZKA	204703200	
460	DISTANCNY KRUZOK MJ	604703100	
461	VACKA	604746100	
462	SKRUTKA FE M 4X8-ZN-8.8	663111010	
463	PODLOZKA FE 4,3-ZN	663111699	
464	SKRUTKA FE M 4X16-ZN	663111193	
465	PODLOZKA FE 4-ZN	663111731	
466	SVORNIK	244550401	
467	MATICA FE M 10-ZN	663111558	
468	PODLOZKA FE 10-A2	663117455	
469	SKRUTKA FE M 8X20-ZN-8.8	663111085	
650-12	KRYT RIAD. SKRINE	204606212	
651-3	SCHEMA ZAPOJENIA Z 298 spínače	244570403	-4 Z 279A, -5 Z296
652	SCHEMA ZAPOJENIA Z 6A B2	204976400	
653	SCHEMA ZAPOJENIA Z 269A B3	204976600	
656-3	VEKO-CIERNE	244532703	
657	TESNENIE	244532100	
658	SKRUTKA FE M 4X10-A2-70	663117804	
664	ODPOR ZRAZACI HSA 25 W 33 OHM	663710864	
665	STITOK REGADA 52 220	644596500	

002-P Silový prevod MPR

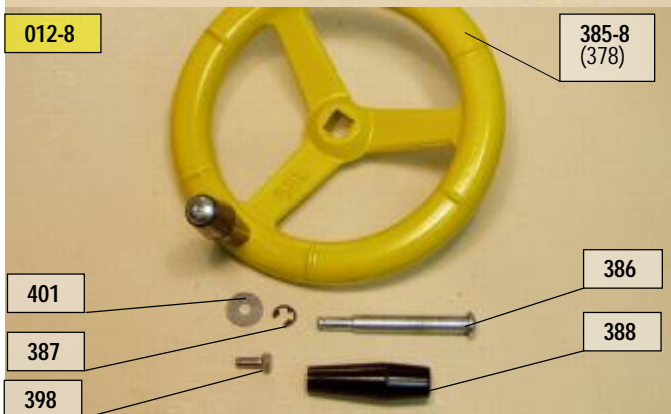
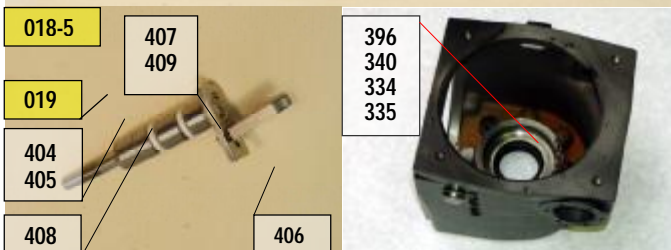
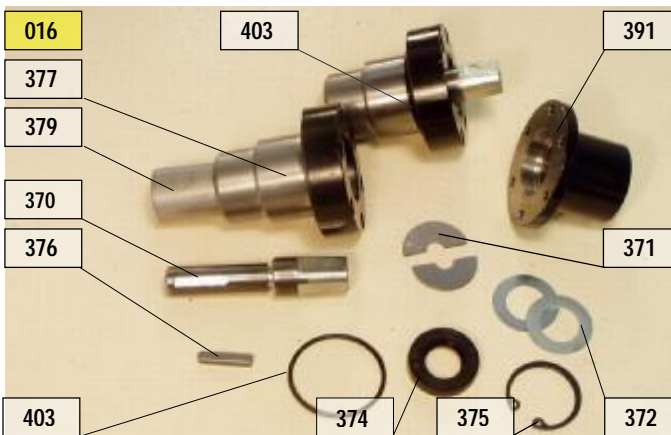
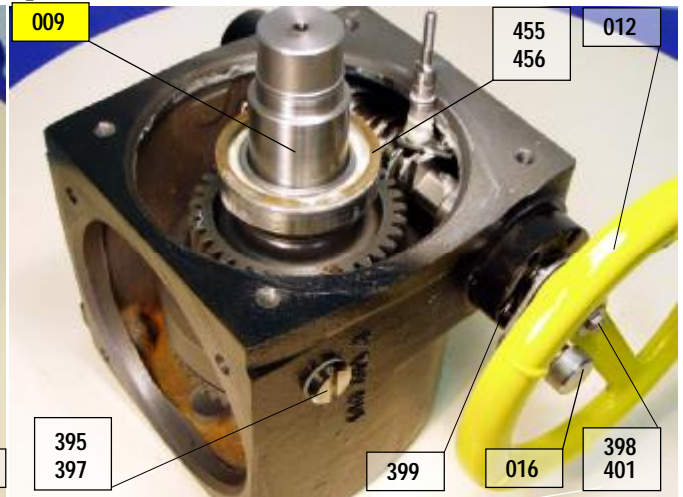

Poz.	Názov	PNm	Poznámky
002-XX	Prevod silový	2245640XX	špec. text.
009-XX	Zostava hriadeľa	2245025XX	špec. text.
010-XX	Závitovka zostava	2245026XX	špec. text.
012-08	Koleso ručné s výrezom	224834608	
016-02	Hriadeľ s aretáciou	224564202	
017-1	Kľuka aretácie	224A11101	
018-5	Ovládač momentový	224502705	
019	Hriadeľ s páčkou	224745100	
334	Podložka	244511600	
335	Podložka distančná	244517000	
340	LOZISKO 6008	663243024	
370-X	HRIADELKA	20463040X	špec. text.
371	SEGMENT	204630500	
372	PODLOŽKA	204630600	
373	PUZDRO II S VLOZKOU-BEZOV	224581301	
374	KR_ŽOKUFERO 16X28X7	662735044	
375	KRUŽOK POIST FE 28	663111801	
376	PERO 4X4X22	663152068	
377	PUZDRO II	204630302	
378	RUCNE KOLO /20DL01010/	244731800	
379	PUZDRO KU 20X30	663243161	
380	SKRUTKA ARETACIE	204970600	
381	KRUŽOK 20X16	662732063	
382	RAMENO ARETACIE	204970800	
383	MATICA ARETACIE	204970700	
384	KRUŽOK 6.9X1.8	662732191	
385-X	KOLESO RUCNE	24473170X	špec. text.
386	CAP RUKOVATE	244732000	
387	KRUŽOK FE 5	663112049	
388	RUKOVAT 8	663210015	
389	PODLOŽKA DISTANCNA	244831900	
390	PODLOŽKA DISTANCNA	244832000	
391	KRYTKA	204867700	
392-6	SKRINA MTR D 80;	204764006	špec. text.
395-1	ZATKA	244833701	
396	KRÚŽOK GUFERO 40X52X7 GP	662735043	
397	PODLOŽKA BA 50 D 14X19X2	662732325	
398	SKRUTKA FE M 5X12-A2	663117040	
399	SKRUTKA FE M 4X12-A2	663117805	
400	SKRUTKA FE M 4X20-A2	663117809	
401	PODLOŽKA FE M 5,5-A2	663117400	
403	KRUŽOK 34X2	662732109	
404	HRIADEL M. J.	204785700	
405	PACKA	244514100	
406	UNASAC	244514300	
407	PODLOŽKA	244840200	
408	KRUŽOK 10X6 MVQ	662732022	
409	KRUŽOK FE 3,2	663111720	
455	PODLOŽKA DISTANCNA	244831600	
456	PODLOŽKA DISTANCNA	244831700	

003-P Ovládacia doska MPR

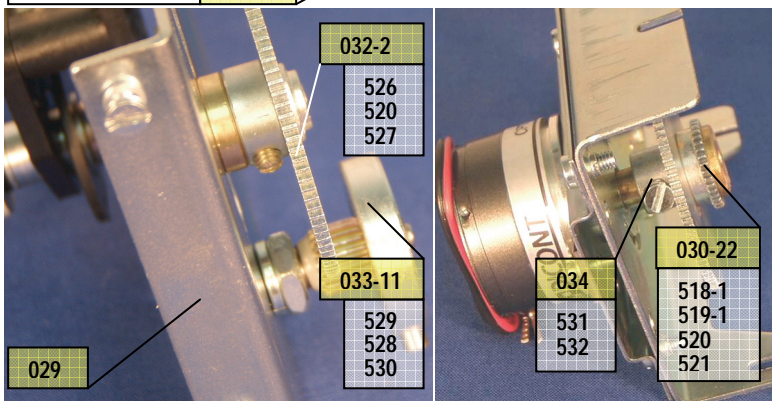
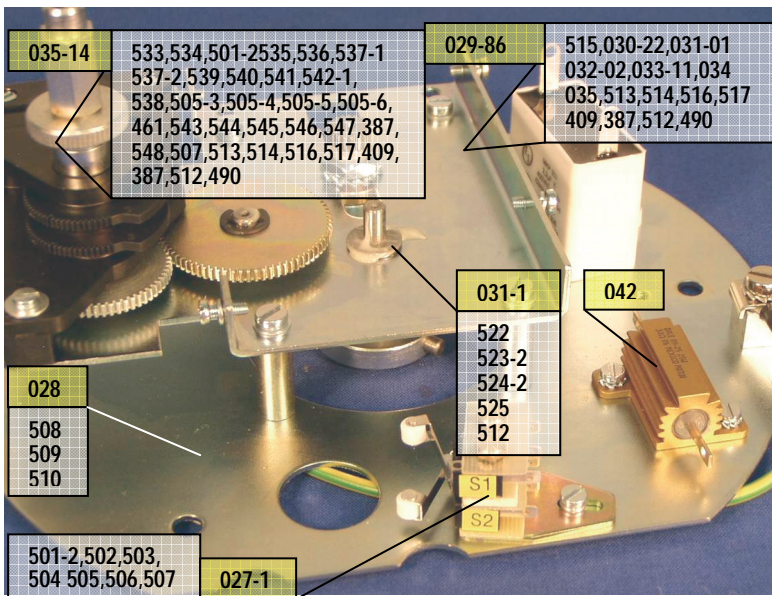
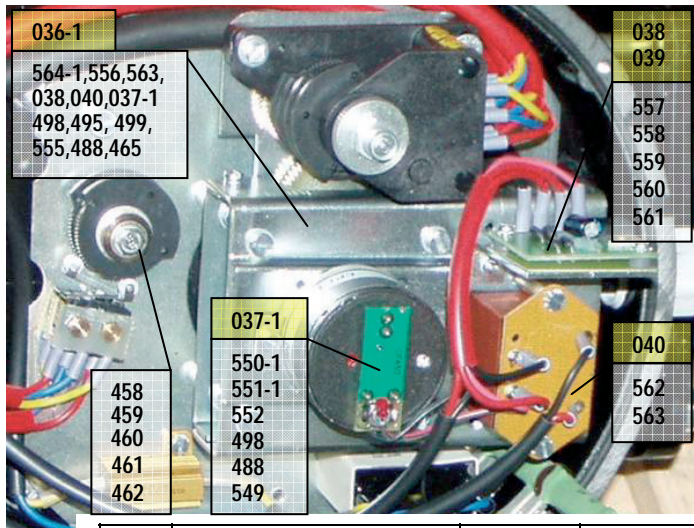
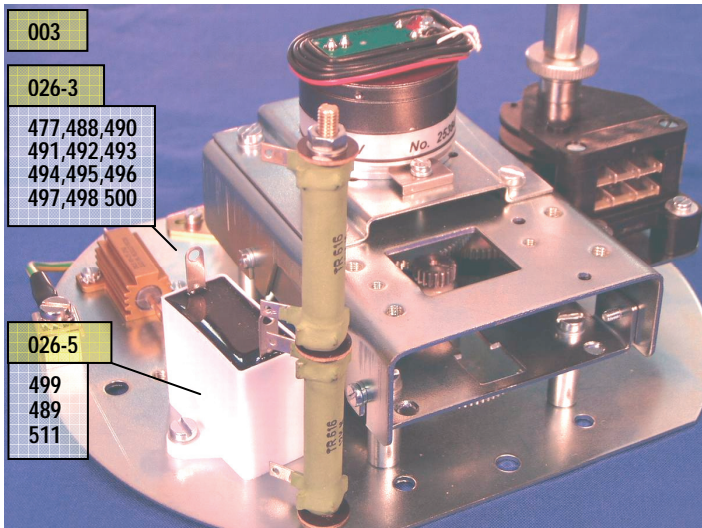

Poz	Názov	PNm	Poznámky
003-XX	OVLADACIA DOSKA 52220 S CPT 1	224744546	špec. text.
026-3	OVLADACIA DOSKA-ZAKLADNA DOSKA	224745603	
026-5	OVLADACIA DOSKA-KONDENZATOR	224745605	
027-1	MOMENTOVE SPINACE	224744801	
028	ZAKLADNA DOSKA SO STLPIKMI	224745800	
029	ZOSTAVA KOTEVNEJ DOSKY 52220	2247457XX	špec. text.
030-XX	ZOSTAVA OZUB.KOLESA Z 45	2245110XX	špec. text.
031-XX	KOTEVNA DOSKA_S CAPMI	22451110X	špec. text.
032-XX	ZOSTAVA_OZUB._KOLESA	22451120X	špec. text.
033-XX	KOTUC_S_PASTORKOM	2245113XX	špec. text.
034	OBJIMKA_SO_SKRUT.	224522000	
035-XX	JEDNOTKA P-S	2247155XX	špec. text.
036-X	UPIN_DOSKA_S_KAP_VYS_CPT_1	224758300	špec. text.
037-X	NOSNIK_S_VYSIELACOM	22475820X	
038	USMERNOVAC	224741300	
039	ZDROJ 24V	228352600	
040	TRANSFORMATOR	224747700	
042	ZRAZACI ODPOR S VODICMI	224768900	
387	KRUZOK FE 5	663112049	
409	KRUZOK FE 3,2	663111720	
458	KRUZOK	204703300	
459	PODLOZKA	204703200	
460	DISTANCNY KRUZOK MJ	604703100	
461	VACKA	604746100	
462	SKRUTKA FE M 4X8-ZN-8.8	663111010	
463	PODLOZKA FE 4,3-ZN	663111699	
477	SKRUTKA MS M 5X10	663118109	
488	PODLOZKA FE 3-ZN	663111729	
489	PODLOZKA FE 4,3-ZN	663112246	
490	PODLOZKA FE 3,2-ZN	663112310	
491	PODLOZKA FE 3,2-ZN	663111740	
492	PODLOZKA	204784200	
493	SVORNIK	244569200	
494	PODLOZKA IZOLACNA	244805600	
495	SKRUTKA FE M 3X8-ZN	663111163	
496	STITOK	644601262	
497	ODPOR TR 616 12K K	663711007	
498	SKRUTKA FE M 3X6 ZN TVAR A	663111160	
499	SKRUTKA FE M 4X8-ZN	663111188	
500	PODLOZKA FE 5,3	663111704	
501-2	PODLOZKA	204703602	
502	DOSKA DISTANCNA	204707000	
503	SKRUTKA	204743800	

Poz	Názov	PNm	Poz.	Poz	Názov	PNm	Pozn.	Poz	Názov	PNm	Pozn.
504	DOSKA	204785800		524-X	ČAP STREDIACI	24454600X		544	MATICA FE M 3-ZN	663111539	
505-X	STITOK OZNAC. MSP	60468090X	text	525	PODLOZKA FE 8-ZN	663111734		545	PODLOZKA FE 6,4-ZN	663111692	
506	PODLOZKA B FE 2,2	663111686		526	NABOJ	244546200		546	KRUZOK FE 6	663111723	
507	MIKROSPINAC DB 6G-B1 RB	664051220		527	SKRUTKA FE M 4X8	663111364		547	KOLIK FE 2X12	663111967	
508	STLPIK ZEMNENIA	204784100		528	KOTUC STREDIACI	244546400		548	PRUZINA 12.5X6.2X0.5X0.85	663152112	
509	DOSKA	204786800		529	PASTOROK A 120°	204912800		549	VYSIELAC KAPACIT CPT 1/AV	664051781	
510	STLPIK	244547000		530	KOLIK FE 4X10	663111484		550-X	NOSNIK	24454810X	text
511	KONDENZATOR MKP 353 2U2/K	663540275		531	OBJIMKA	244565100		551-X	PUZDRO	24454830X	text
512	MATICA FE M 8X1-ZN	663112289		532	SKRUTKA FE M 4X6-ZN	663111839		552	PRICHYTKA	244949400	
513	PUZDRO	244545000		533	MATICA RYHOVANA M6	204660000		553	DOSKA UPINACIA	204828700	
514	KOLESO PRENOSOVE	244545300		534	PODLOZKA TRECIA	204661200		554-X	STLPIK DISTANCNY IND.VYS	20477640X	text
515	PASTOROK S OSKOU C-120°	204913200		535	HRIADEL J.P-S	204709300		555	PODLOZKA FE 3,2-ZN	663111710	
516	SKRUTKA FE M 3X14-ZN	663111168		536	MATICA	204709400		556	PODLOZKA	204786300	
517	PODLOZKA FE 8,4	663111715		537	PODLOZKA DISTANCNA	244853900		557	NOSNIK SP 1-IND.VYS	204776100	
518-X	OZUBENE KOLO.	20478670X		538-X	PODLOZKA DISTANCNA	20470950X	text	558	DOSKA IZOLACNA SP-OVL.	204776200	
519-X	PUZDRO	24454660X		539-X	UZAVER JPS	20470970X	text	559	STLPIK DISTANCNY IND.VYS.	204776300	
520	KOLESO OZUBENE	244555700		540	TYCKA MSP	204709800		560	SKRUTKA FE M 2,5X8 ZN	663111156	
521	KOLIK FE 2X6	663111453		541	KOLESO /160°/	204715600		561	PODLOZKA FE 2,7-ZN	663112747	
522	DOSKA KOTEVNA	204786600		542-X	KOSTRA JPS	22471650X	text	562	DOSKA S PAJACIMI OKAMI	224747500	
523	CAP OZUB.KOLESA	244545902		543	SKRUTKA FE M 3X22-ZN	663111173		563	TRANSFOR MYRRA 1X18V	664031156	

004 Predlový prevod ES MPR Variant

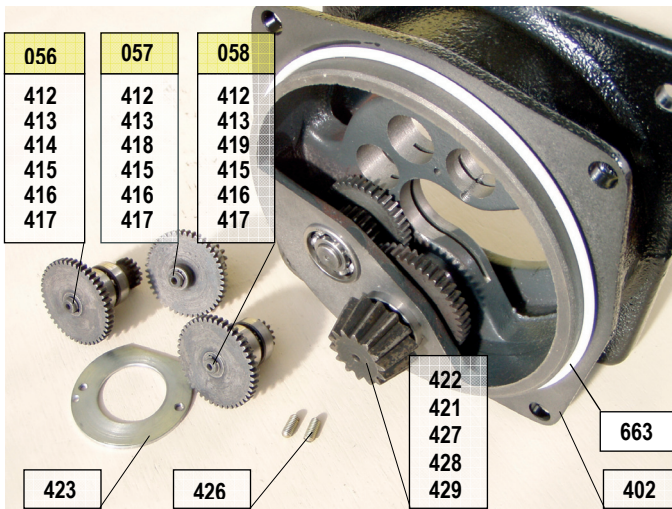
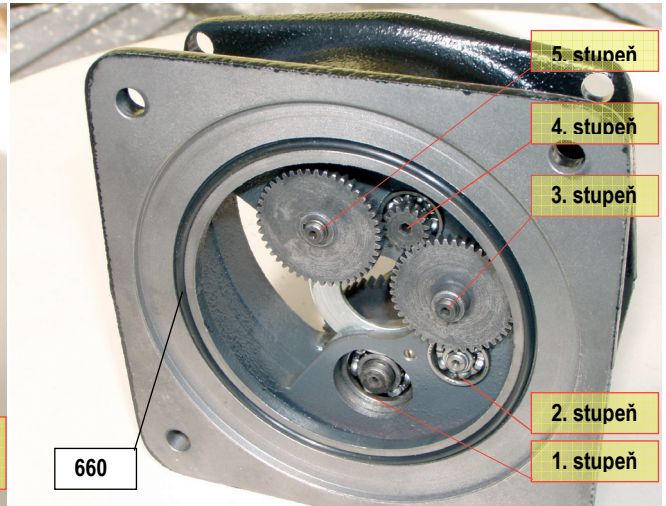
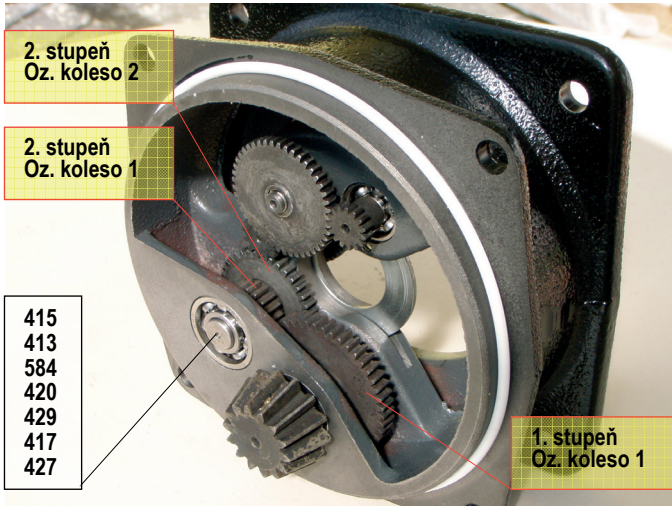

004	1.Stup/Oz.1	2.Stup/Oz.1	2.Stup/Oz.2	3,4,5 Stupeň
004-1	424	425	393	056, 057, 058
004-2	425	424		
004-3	662	661		
004-4	424	425		
004-5	425	424		
004-6	662	661		

Poz.	Názov	PNm	Poznámky
004-1	PREVOD PREDLOHOVÝ	224529301	N2 25-63 Nm
004-2	PREVOD PREDLOHOVÝ	224529302	T2 25-63 Nm
004-3	PREVOD PREDLOHOVÝ	224529303	N2 40-100Nm
004-4	PREVOD PREDLOHOVÝ	224529304	T2 40-100Nm
004-5	PREVOD PREDLOHOVÝ	224529305	N2 80-125Nm
004-6	PREVOD PREDLOHOVÝ	224529306	T2 80-125Nm
056	KOLESO OZUBENE A PASTOROK	224521400	5. Stupeň
057	KOLESO OZUBENE A PASTOROK	224521500	4. Stupeň
058	KOLESO OZUBENE A PASTOROK	224521600	3. Stupeň
393	KOLESO OZUBENE	204643900	
402-1	MEDZIPRIRUBA	244589701	02-T2
412	KOLESO OZUBENE	244570000	
413	KRUZOK DIST.	244571100	
414	PASTOROK	244946300	
415	KRUZOK FE 6	663112501	
416	PERO 2X2X8	663152093	
417	LOZISKO 626	663243016	
418	PASTOROK	244946400	
419	PASTOROK	204643800	
420	HRIADEL	244571000	
421	KRUZOK DIST.	244571200	
422	PASTOROK	244571400	
423	KRUZOK ZAISTOVACI	244571500	
424	KOLESO OZUBENE	244593100	
425	KOLESO OZUBENE	244593200	
426	SKRUTKA FE M 4X10	663112111	
427	KRUZOK FE 10	663112502	
428	PERO 3X3X12	663152092	
429	LOZISKO 6000	663243023	
584	PERO 3X3X22	663152091	
661	KOLESO OZUBENE	244593300	
662	KOLESO OZUBENE	244593400	
660	KRUZOK 100X3	662732117	
663	KRUZOK 125X3	662732115	

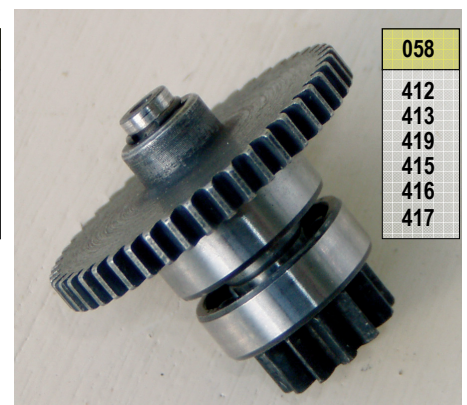
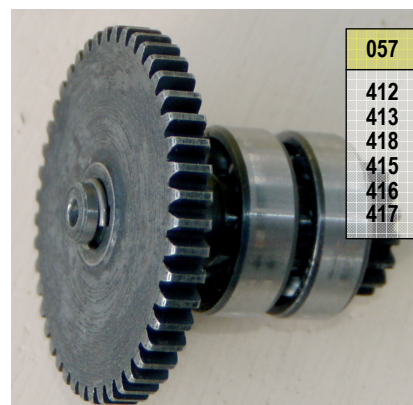
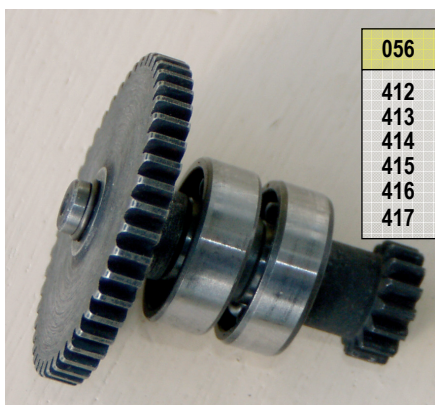

005-P Zostava riadiacej skrine MPR Variant

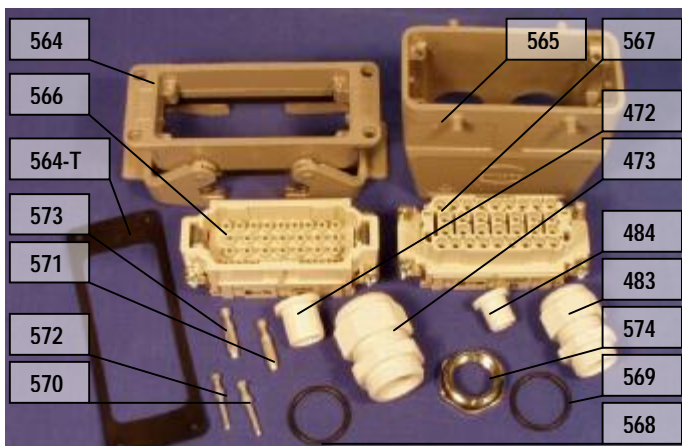
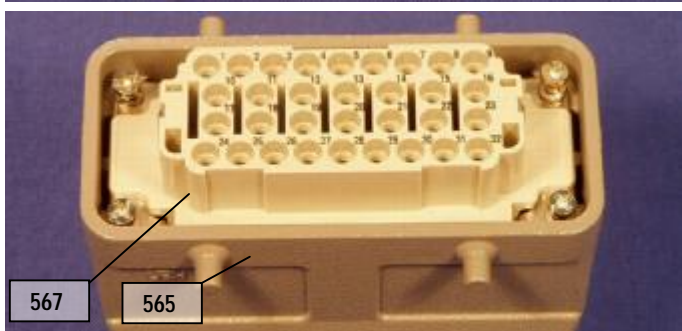
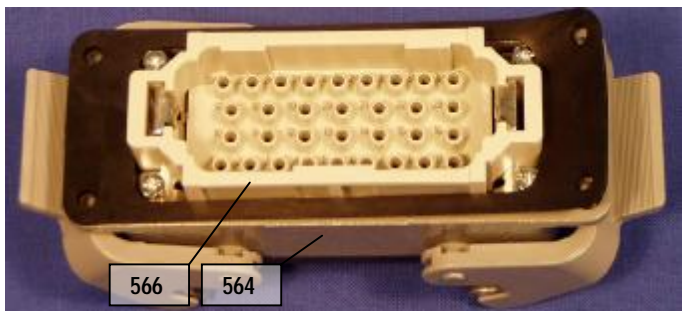
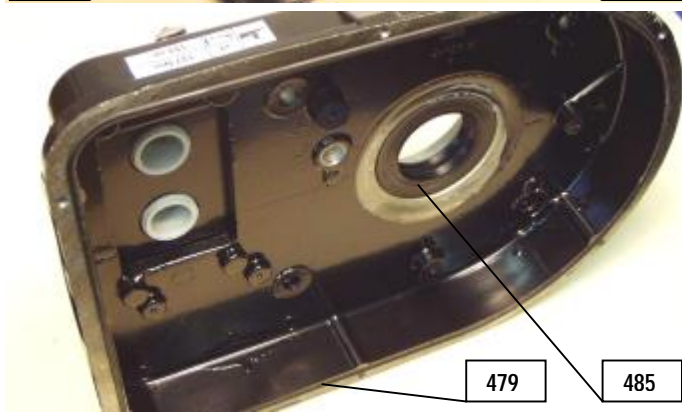
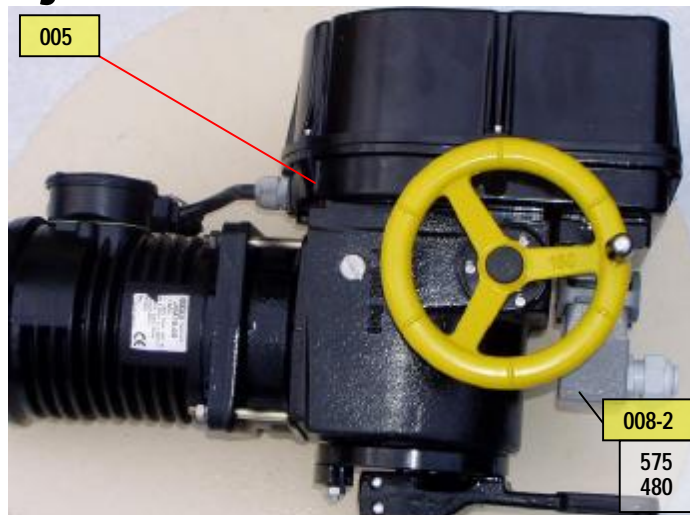
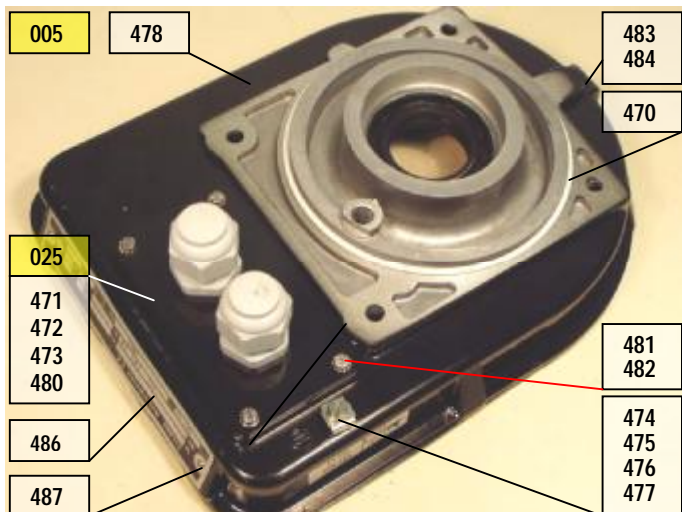

Poz	Názov	PNm	Poznámky
005-01	SKRINA RIADIACA-VYVODKY	224A21101	IP 65 MPR, MTR
005-04	SKRINA RIADIACA-KONEKTOR	224A21104	IP 65 MPR, MTR
005-22	SKRINA RIADIACA-VYVODKY	224A21122	IP 55 MPR, MTR
005-25	SKRINA RIADIACA-KONEKTOR	224A21125	IP 55 MPR, MTR
008-X	ZOSTAVA KONEKTOROV-HARTING	224A0020X	špec. textom
025-X	DOSKA S VYVODKAMI-CIERNA	224A2070X	špec. textom
041-X	SVORKOVNICA ZOSTAVA-S	224A0690X	špec. textom
470	KRUZOK 130X3	662732095	
471-2	DOSKA-OPRACOVANIE	204A01402	
472	OCHR.KRYTKA TESNIACA M25X1,5	663457028	
473	VYVODKA KÁBELOVÁ M 25X1,5	663457017	
474	PODLOZKA	244503400	
475	PODLOZKA	244532500	
476	PODLOZKA FE M 5	663117452	
477	SKRUTKA MS M 5X10	663118109	
478-12	SKRINA RIADIACA	204A78312	IP 65 KON-VYV
478-01	SKRINA RIADIACA	204A78301	IP 55 KON-VYV
479	TESNENIE RIADIACEJ SKRINE	604A05199	
480	TESNENIE	604A04799	
481	SKRUTKA FE M 4X12-A2	663117735	
482	PODLOZKA MS 4,3	663118624	
483	VYVODKA KÁBELOVÁ M 20X1,5	663457013	
484	OCHR.KRYTKA TESNIACA M20X1,5	663457025	
485	GUFERO GP 40X62X7	662735002	
486-2	STITOK	244536102	
487	RYH. KLINEC FE 2,49X4,76-NI	663111904	
564	KRYT PANELOVY HAN 16B	663456695	
564-T	KRYT PANELOVY HAN 16B	663456695	tesnenie súčasťou
565	TELESO KONEKT. M25 BOČNE	663456755	
566	ZASUVKA HAN 32 EE-M	663456713	
567	VIDLICA HAN 32 EE-F	663456712	
568	KRUZOK 22X2	662732046	
569	KRUZOK 20X2	662731034	
570	KOLIK 0.5 MM2	663456714	
571	DUTINKA 0.5 MM2	663456715	
572	KOLIK 1 MM	663456718	
573	DUTINKA 1 MM	663456719	
574	REDUKCIA RS-MSM25X1.5/M20X1.5	663457081	
575	SKRUTKA MS M 4X20	663118106	upevnenie konektora
576-X	STLPIK DISTANČNY MO-SVORKOVNCA	20495260X	03, 04
577	PLECH	204598400	
578-X	PLECH SVORKOVNICE	20495220X	01
579	SVORKOVNICA LTA 12-4 OP TXP310P	663456709	
580	MATICA FE M 4-ZN-8.8	663111542	
581	PODLOZKA FE 3,2-ZN	663111701	
582	SKRUTKA FE M 4X8	663111298	
583-12	STITOK SVORKOVNICE	204959612	
583-13	STITOK SVORKOVNICE	204959613	
583-14	STITOK SVORKOVNICE	204959614	
583-15	STITOK SVORKOVNICE	204959615	

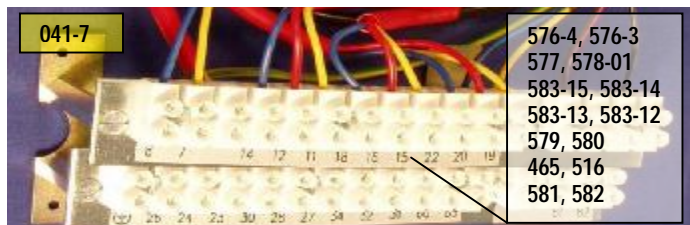

009-XX Zostava hriadeľa 224 5025 XX

10-XX Závitovka zostava 224 5026 XX

List 1/1

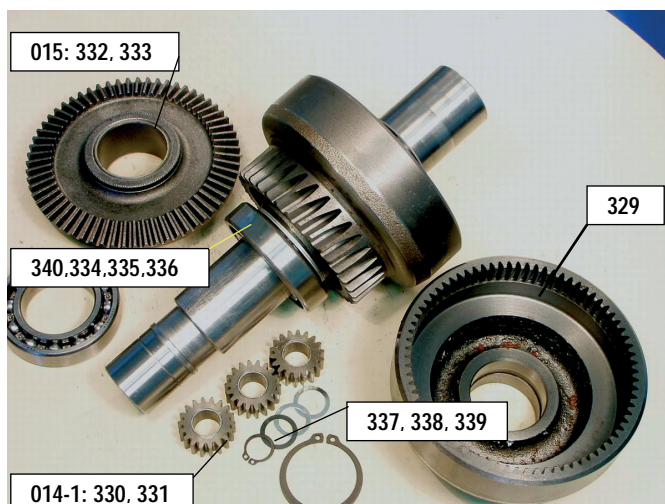
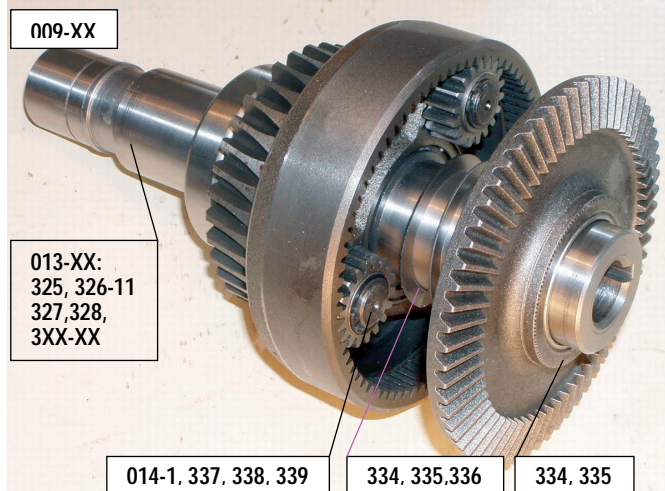

010-21 Závitovka zostava 224 5026 21(XX)

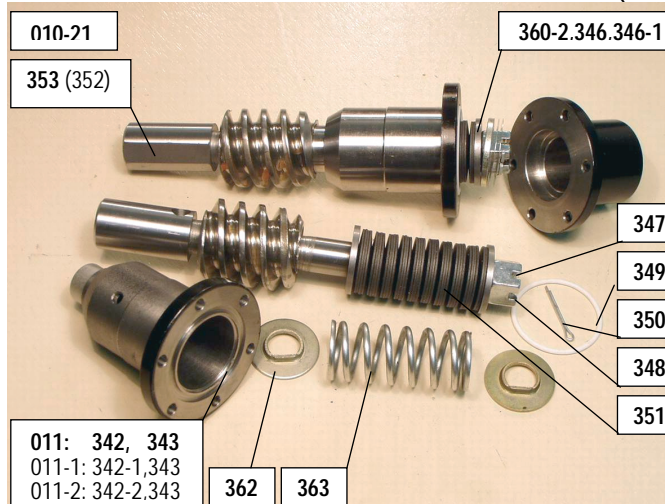

02	341-1,345,346,347,348,349,350,352,354,355,356,357,359
03	341-1,346,347,348,349,350,352,354,355,356,357,359
04	341-1,346,347,348,349,350,352,354,355,356,358,359
05	341-1,345,346,347,348,349,350,352,354,355,356,359
06	341-1,346,347,348,349,350,352,354,355,356,359
07	341-1,346,347,348,349,350,352,354,355,356,358,359
08	341-1,345,346,347,348,349,350,352,354,355,356,359
10	341-3,345,346,347,348,349,350,352,354,355,356,359
11	346,346-1,347,348,349,350,353,359,360-3,011
12	346,346-1,347,348,349,350,353,359,011,360-2
13	346,346-1,347,348,349,350,353,359,011,360-2
14	346,346-1,347,348,349,350,353,359,011,360-2
15	346,346-1,347,348,349,350,353,359,011-1,360-2
16	346,346-1,347,348,349,350,353,359,011,360-2
17	346,346-1,347,348,349,350,353,359,360-3,011
18	346,346-1,347,348,349,350,353,359,011,360-2,360-3
19	346,346-1,347,348,349,350,353,360-3,011,361
20	346,346-1,347,348,349,350,353,360-3,011,362,363
21	346,346-1,347,348,349,350,351,353,360-2,011
22	346,347,348,349,350,353,351,360-3,011
23	347,348,349,350,353,011,360-2,362,364
24	347,348,349,350,353,011,360-2,362,365
25	347,348,349,350,353,011,360-2,368
26	347,348,349,350,353,011,360-2,362,363,366
27	347,348,349,350,353,360-3,011,367,369
28	346,347,348,349,350,353,360-3,011
29	346,347,348,349,350,351,353,360-3,011-2
30	346,346-1,347,348,349,350,353,358,011-2

329	Veniec	244512700
330	Satelit	204843100
331	Puzdro KU 1412	663243150
332	Koleso kuželové	244512200
333	Ložisko KU 40x30	663249037
334	Podložka	244511600
335	Podložka dištančná	244517000
336	Podložka	244517300
337	Podložka	244868901
338	Podložka	244868902
339	Kružok poistný FE 14	663111943
340	Ložisko 6008	663243024
341	Puzdro	244513600
342-X	Puzdro	20462960X
343	Puzdro KU 14x15	663243160
344-2	Rozperka	244508902
345	Podložka	244513300
346	Podložka s=0,2	244513400
346-1	Podložka s=0,3	244513401
347	Matica	244513500
348	Podložka	244538900
349	Kružok 3167 32x2	662732097
350	Zavlačka	663111756
351	Pružina TF 25x12,2x0,96x1,6	663152158
352	Závitkový hriadeľ	244512800
353	Závitkový hriadeľ	204867600
354	Zátka	244513700
355	Podložka dištančná	244832700
356	Podložka dištančná	244832800
357	Podložka upch. P21x20	662731060
358	Podložka	244519200
359	Pružina TF 25X12,2X0,7X1,6	663152071
360-2	Rozperka	244506902
360-3	Rozperka	244506903
361	Pružina TF 23X12,2X1,0	663152075
362	Podložka pre valcové pružiny	244891800
363	Pružina	644867100
364	PRUŽINA TL 3150X232X0480	663152189
365	PRUŽINA TL 2500X225X0530	663152191
366	RURKA VYMEDZOVACIA	204721300
367	PRUŽINA TL 3150X192X0500	663152190
368	PRUŽINA TL 2000X180X0530	663152192
369	Pružina 28X12,2X1,25 GR2	663152156

009-XX	Zostava hriadeľa	2245025XX	špecifikovať textom
010-XX	Závitovka zostava	2245026XX	špecifikovať textom
011	Puzdro s vložkou	224581400	
011-1	Puzdro s vložkou	224581401	
011-2	Puzdro s vložkou	224581402	
013-XX	Hriadeľ s unášačom	2245024XX	viď 013-XX
014-1	Satelit	224502901	
015	Koleso kuželové	224503000	
3XX-XX	Výstupný hriadeľ	2XXXXXXX	viď 3XX-XX
325-13	Unášač 3 drážky	244511913	v 013-XX
326-11	Čap	244512011	v 013-XX
327	Kružok poistný FE 40	663111966	v 013-XX
328	Pero 8x7x20	663152070	v 013-XX

Poznámka: Dielce pre jednotlivé vyhotovenia závitovky sú rozpísané v hornej tabuľke ale nie sú všetky zobrazené.

013-xx Hriadel' s unášačom 224 5024 XX

List 1 z 3

XX	325-XX Unášač 244 5119 XX	326-11 Čap 244 5120 11	327 Kr. po 40	328 Pero 8x7x20	3XX-XX Výstupný hriadel'	Poznámky 1	Poznámky 2	
01	12	+	+	+	301	244 5393 00	L=243,5 2P 4zu30 ⁰	MO diera skrz Ø28
02	12	+	+	+	302	204 9243 00	L=180,6 2P, 2 zu14	T-C, koniec Ø30,3/17
03	12	+	+	+	303	244 5118 00	L=253,5 2P 4zu30 ⁰	MO diera skrz Ø28
04	-							
05	12	+	+	+	304	244 5371 00	L=181 2P 4zu30 ⁰	die skrz Ø28 koniec Ø30,3/17
06	12	+	+	+	305	244 5503 00	L=239,1 2P PØ25P8	MP plný
07	12	+	40,26, 32	+	306 307	244 6051 00 244 6052 00	L=247, MP-E L=262, Ø11 tyč	Základné vyhotovenie
08	-							
09	12	+	+	+	308	204 6140 00		Nemá výkres v systéme
10	-							
11	11	+	+	+	309	244 9468 00	L=243,5 4P 4zu30 ⁰	MO diera skrz Ø28
12	12	+	+	+	310	244 5392 00	L=253,5 2P, 2 zu14	MO-Ex T-C diera skrz Ø28
13	13	+	+	+	311-28	204 A013 28	L=250,5 3P DØ25P8	diera, plný kon MO 3.5, kr.je.
14	12	+	+	+	305-01	244 5503 01	L=239,1 2PPØ252P8	MP závora plný s M8 a 2P8
15	12	+	+	+	313	204 8578 00	L=234,6 2P PØ25P8	MP plný, závit M4 na konci
16	11	+	+	+	314-01	244 9942 01	L=253,5 4P, 4zu45 ⁰	MO-Ex T-C diera skrz Ø28
17	11	+	+	+	309-01	244 9468 01	L=253,5 4P 4zu30 ⁰	MO-Ex diera skrz Ø28
18	11	+	+	+	315	204 8551 00	L=243,5, 4P, T-C	01: L=253,5, 4P, T-C
19	12	+	+	+	316	204 9125 00	L=220,6 2P, Ø25P8	MP plný ,koniec Ø30,3/17
20	12	+	+	+	310-01	244 5392 01	L=243,5 2P, 2 zu14	MO T-C diera skrz Ø28
21	11	+	+	+	317	204 9306 00	L=296,5 4P, Ø20P6	P-1103/02
22	11	+	+	+	315-01	204 8551 01	L=253,5, 4P, T-C	03 L=180,7 4P T-C, Ø30/17 04 L=243,5 4P T-C MO
23	11	+	+	+	317-01	204 9306 01	L=233,7 4P, Ø20P6	P-1103/02, T-C, Ø30/17
24	11	+	+	+	315-04	204 8551 04	L=243,5 4P, Ø15P5	MO,T-C Ø15H8
25	11	+	+	+	302-01	204 9243 01	L=180,6 4P, 4xzub	MO, 4xzub, CPT, Ø30/17
26	11	+	+	+	315-03	204 8551 03	L=180,7 4P, Ø20P6	MO,P-1103/03T-E,CPTØ30/17
27								
28								
29								
30								
31	Tri drážky 13	+	+	+	311-00	204 A013 00	L=243,5 3P 4xzub	MO, 4x45 Rusko
32	Tri drážky 13	+	+	+	311-01	204 A013 01	L=253,5 3P 4xzub	MO-Ex, 4x45 Rusko
33	Tri drážky 13	+	+	+	311-02	204 A013 02	L=243,5 3P 4xzub	MO-MT, 4x30 Rusko
34	Tri drážky 13	+	+	+	311-03	204 A013 03	L=243,5 3P Ø20P6	MO Mapol
35	Tri drážky 13	+	+	+	311-04	204 A013 04	L=253,5 3P Ø20P6	MO-Ex Mapol
36	Tri drážky 13	+	+	+	311-05	204 A013 05	L=180,7 3P Ø20P6	MO, CPT Ø30,3/17
37	Tri drážky 13	+	+	+	311-06	204 A013 06	L=243,5 3P Ø15P5	MO
38	Tri drážky 13	+	+	+	311-09	204 A013 09	L=180,7 3P 2 zu14	MOCPT+Kotúč 204A64600
39	Tri drážky 13	+	+	+	311-10	204 A013 10	L=180,7 3P 4zu45 ⁰	MOCPT+Kotúč 204A64600
40	Tri drážky 13	+	+	+	311-11	204 A013 11	L=253,5 3P 4zu30 ⁰	MO,MT-Ex 4x30
41	Tri drážky 13	+	+	+	311-12	204 A013 12	L=239,1 3P PØ25P8	MP plný hriadel'
42	Tri drážky 13	+	+	+	311-13	204 A013 13	L=239,1 3P PØ20,9P8	MP plný hriadel' 2x pero P8
43	Tri drážky 13	+	+	+	311-14	204 A013 14	L=228,6 3P PØ25P8	MP, MPR CPT, c
44	Tri drážky 13	+	+	+	311-15	204 A013 15	L=180,7 3P 4zu30 ⁰	MO, MT CPT 4x30, Ø31/17
45	Tri drážky 13	+	+	+	311-16	204 A013 16	L=253,5 3P 2 zu14	MO-Ex drážka 14
46	Tri drážky 13	+	+	+	311-17	204 A013 17	L=243,5 3P 2 zu14	MO drážka 14
47	Tri drážky 13	+	+	+	311-18	204 A013 18	L=296,5 3P PØ20P6	Plný hriadel' 1103/02
48	Tri drážky 13	+	+	+	311-19	204 A013 19	L=233,7 3P PØ20P6	Plný hriael' 1103/02, Ø30,3/17
49	Tri drážky 13	+	+	+	311-20	204 A013 20	L=234,6 3P PØ25P8	Plný hr. MPR, OV
50	Tri drážky 13	+	+	+	311-21	204 A013 21	L=244,5 3P 4zu45 ⁰	MO 4x45 Rusko IP55
51	Tri drážky 13	+	+	+	311-22	204 A013 22	L=244,5 3P 4zu30 ⁰	MO MT 4x30 Rusko IP55
52	Tri drážky 13	+	+	+	311-25	204 A013 25	L=244,5 3P 2 zu14	MO drážka 14
53	Tri drážky 13	+	+	+	311-26	204 A013 26	L=240,5 3P DØ25P8	MO 3.5 D25 diera s perom 8
54	Tri drážky 13	+	+	+	311-27	204 A013 27	L=177,7 3P DØ25P8	MO3.5P,diera s P8, Ø30,3/17
55	Tri drážky 13	+	+	+	311-29	204 A013 29	L=180,7 3P D20x20	Diera 20x20, Ø30,3/17
56	Tri drážky 13	+	+	+	311-30	204 A013 30	L=253,5 3P D20x20	MO-Ex Diera 14x14
57	Tri drážky 13	+	+	+	311-31	204 A013 31	L=339,5 3P PØ30P8	MO Plný hriael'
58	Tri drážky 13	+	+	+	311-35	204 A013 35	Ø00-6,9-22,25-43	MO 25x25
59	Tri drážky 13	+	+	+	312	204 B093 00	L=214 3P DØ25P8	diera, plný kon MO 3.5, kr.je.
60	Tri drážky 13	+	+	+	311-36	204 A013 36	L=217,5 3P DØ20P6	Plný hr. MO 20/6 krok.j.
61	Tri drážky 13	+	+	+	311-42	204 A013 42	L=244,5 3P 2 zu14	MO vrtanie Ø29,2, dráž. 14
62	Tri drážky 13	+	+	+	311-43	204 A013 43	L=243,5 3P DØ22P6	MODiera ØD22, 2P6 Ma
63	Tri drážky 13	+	+	+	311-41	204 A013 41	L=293,5 3P 4zu30 ⁰	MO,MT 4x30, krok.j.
64	Tri drážky 13	+	+	+	311-40	204 A013 40	L=293,5 3P 4zu45 ⁰	MO,MT 4x45 krok.j.
99	Tri drážky 13	+	+	+	-	Bez hriadela		MO 3.3

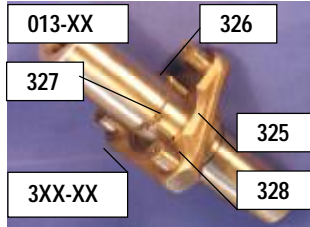

301 (L=243,5 2xP 4zu30°) 302 (L=180,6; 2xP; TVAR C) 303 (L=253,5 2xP 4zu30°)

--	--	--	--

304 (L=181 2P 4zu30°) 305 (L=239,1 2P PØ25P8) 306,307(L=247. MP-F. L=262. Ø11 tvč) 308(.....)

--	--	--	--

309 (L=243,5 4P 4zu30°) 310(L=253,5 2P, 2 zu14) 311-28 (L=250,5 3P DØ25P8) 305-01 (L=239,1 2PPØ252P8)

--	--	--	--

313 (L=234,6 2P PØ25P8) 314-01(L=253,5 4P, 4zu45°) 309-01(L=253,5 4P 4zu30°) 315 (L=243,5, 4P, T-C)

--	--	--	--

316 (L=220,6 2P, Ø25P8) 310-01(L=243,5 2P, 2 zu14) 317(L=296,5 4P, Ø20P6) 315-01 (L=253,5, 4P, T-C)



317-01 (L=233,7 4P, Ø20P6) 315-04 (L=243,5 4P, Ø15P5) 302-01 (L=180,6 4P, 4xzub) 315-03 (L=180,7 4P, Ø20P6)

--	--	--	--

311-00 (L=243,5 3P 4xzub) 311-01 (L=253,5 3P 4xzub) 311-02 (L=243,5 3P 4xzub) 311-03 (L=243,5 3P Ø20P6)

--	--	--	--

311-04 (L=253,5 3P Ø20P6) 311-05 (L=180,7 3P Ø20P6) 311-06 (L=243,5 3P Ø15P5) 311-09 (L=180,7 3P 2 zu14)

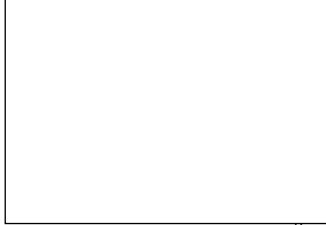
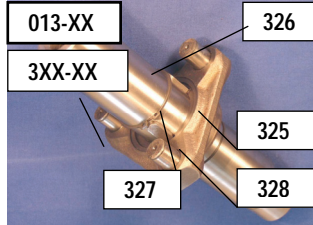

311-10 (L=180,7 3P 4zu45⁰) 311-11 (L=253,5 3P 4zu30⁰) 311-12 (L=239,1 3P PØ25P8)



311-13 (L=239,1 3P PØ20,9P8) 311-14 (L=228,6 3P PØ25P8) 311-15 (L=180,7 3P 4zu30⁰) 311-16 (L=253,5 3P 2 zu14)



311-17 (L=243,5 3P 2 zu14) 311-18(L=296,5 3P PØ20P6) 311-19(L=233,7 3P PØ20P6) 311-20 (L=234,6 3P PØ25P8)

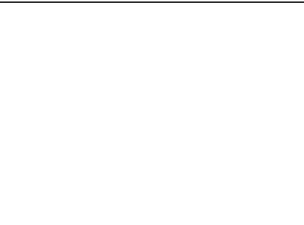
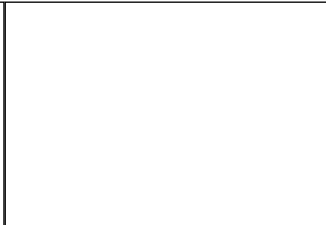

311-21 (L=244,5 3P 4zu45⁰) 311-22 (L=244,5 3P 4zu30⁰) 311-25(L=244,5 3P 2 zu14) 311-26 (L=240,5 3P DØ25P8)

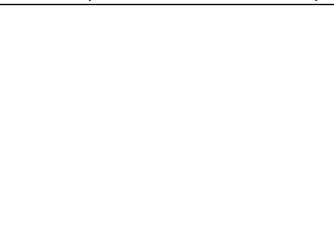
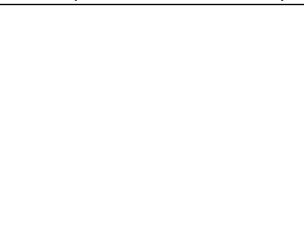

311-27 (L=177,7 3P DØ25P8) 311-29 (L=180,7 3P D20x20) 311-30(L=253,5 3P D20x20) 311-31 (L=339,5 3P PØ30P8)

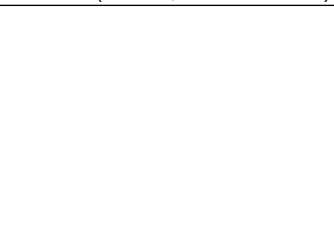
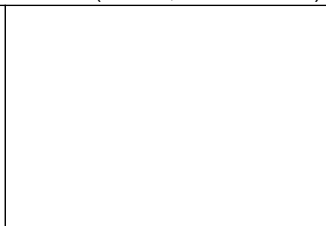
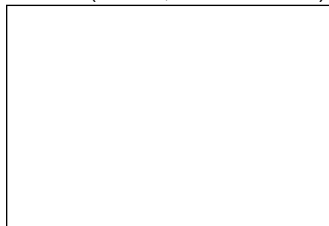

311-35 (MO 25x25) 312 (L=214 3P DØ25P8) 311-36(L=217,5 3P DØ20P6) 311-42 (L=244,5 3P 2 zu14)

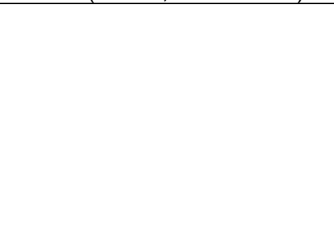
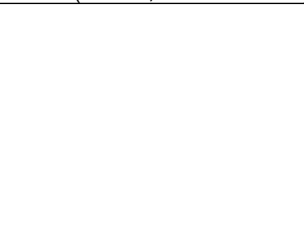
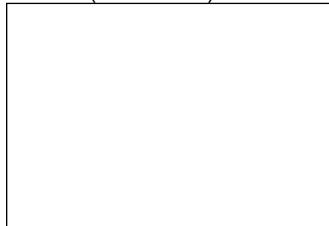

311-43 (L=243,5 3P DØ22P6) 311-41 (L=293,5 3P 4zu30⁰) 311-40 (L=293,5 3P 4zu45⁰) (.....)

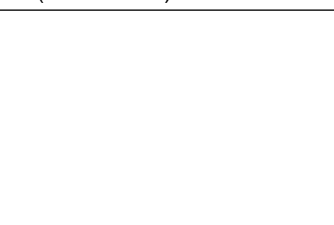
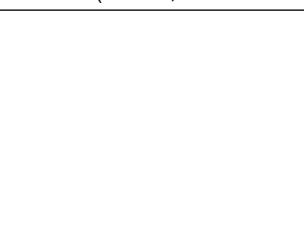
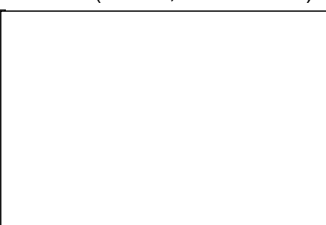
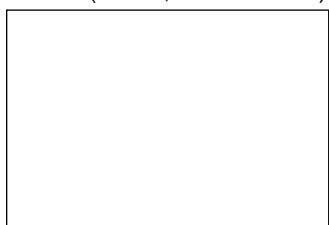

(.....)

(.....)

(.....)

(.....)