

**REGADA** s. r. o., Strojnícka 7, Prešov

## Katalóg náhradných dielov

Typ MO, t.č. 52 000

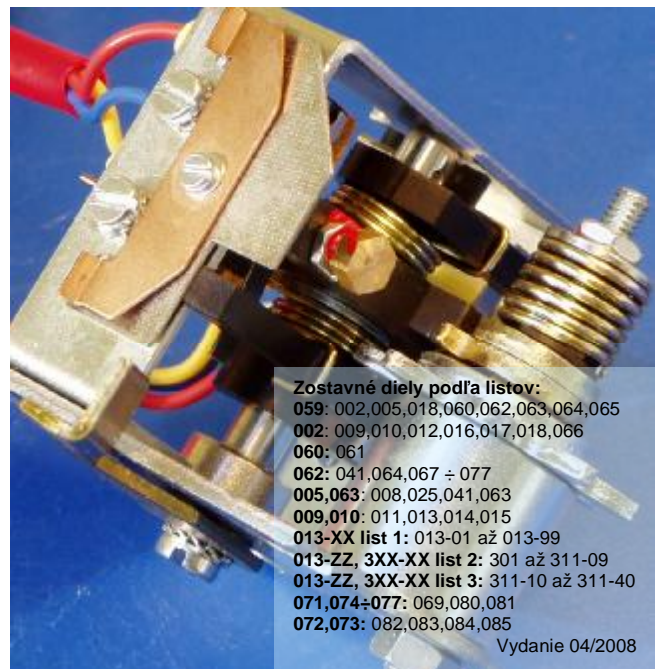
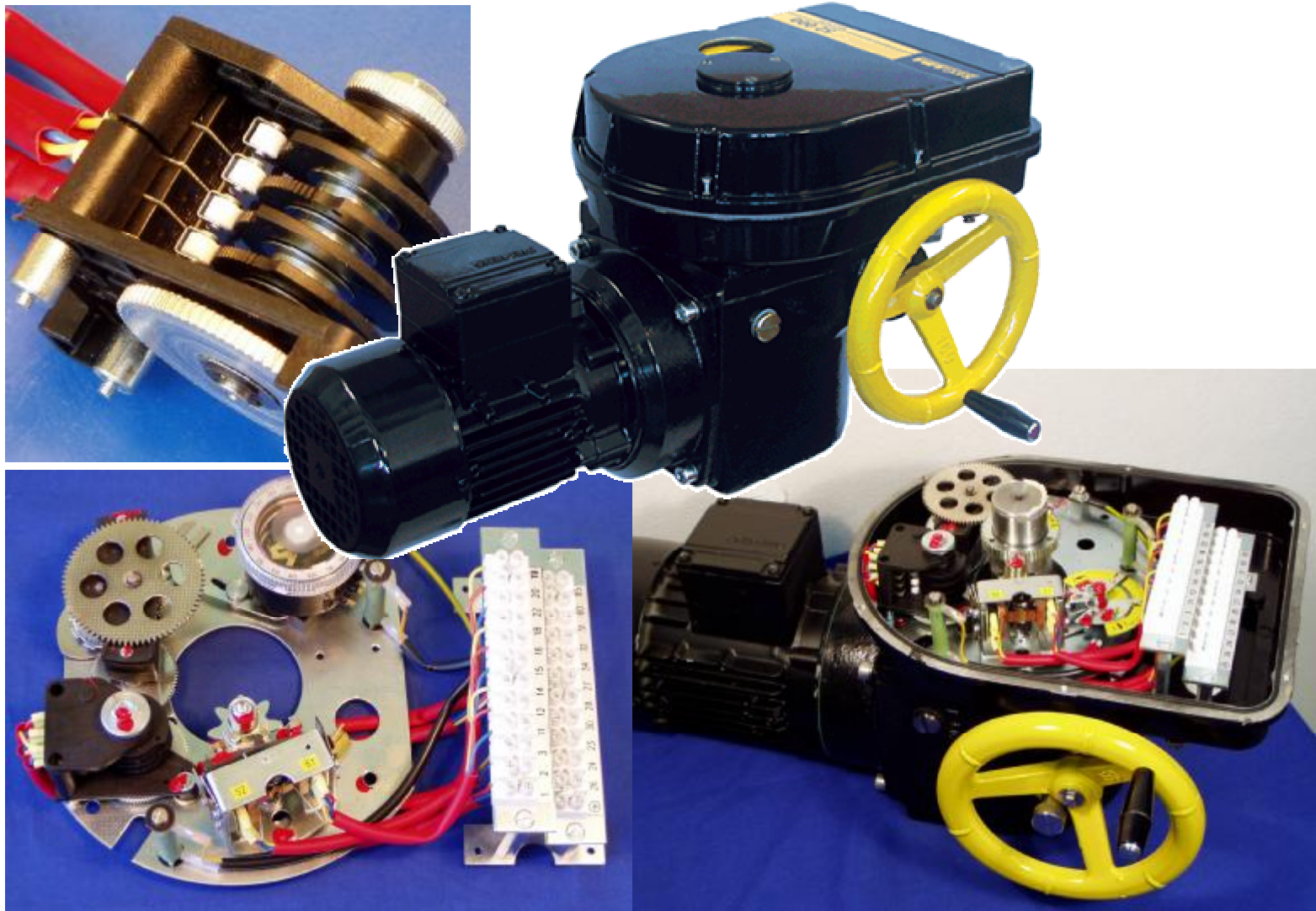

Zostavné diely podľa listov:  
059: 002,005,018,060,062,063,064,065  
002: 009,010,012,016,017,018,066  
060: 061  
062: 041,064,067 ÷ 077  
005,063: 008,025,041,063  
009,010: 011,013,014,015  
013-XX list 1: 013-01 až 013-99  
013-ZZ, 3XX-XX list 2: 301 až 311-09  
013-ZZ, 3XX-XX list 3: 311-10 až 311-40  
071,074÷077: 069,080,081  
072,073: 082,083,084,085

Vydanie 04/2008

# 002-O Silový prevod MO 52 000 plyn. náh.

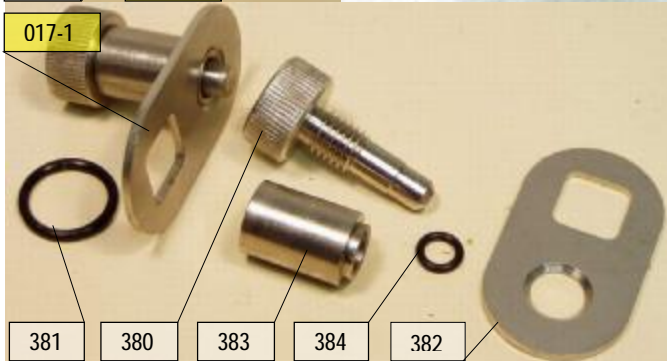
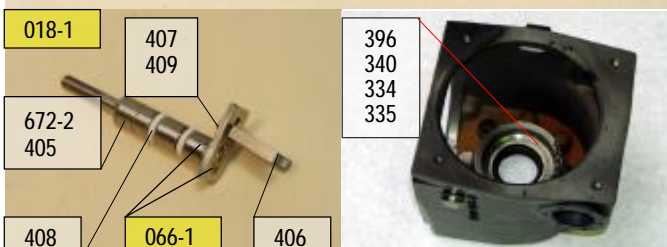
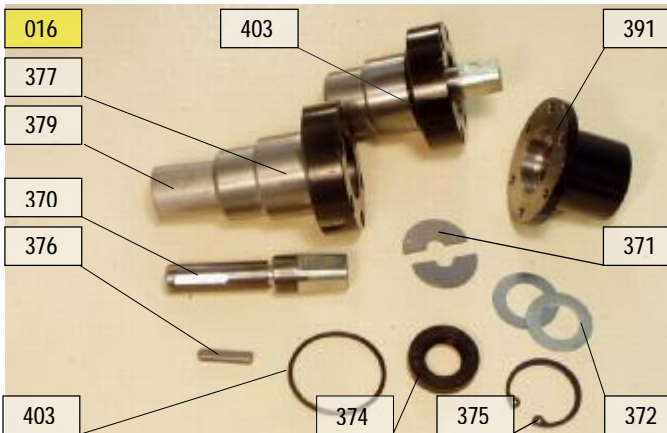
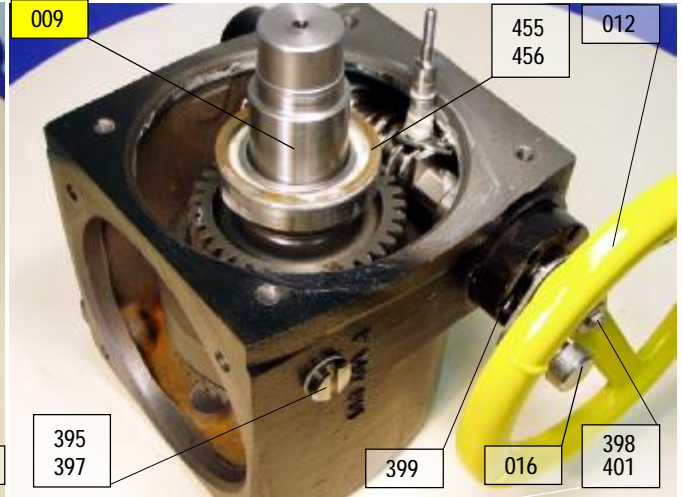
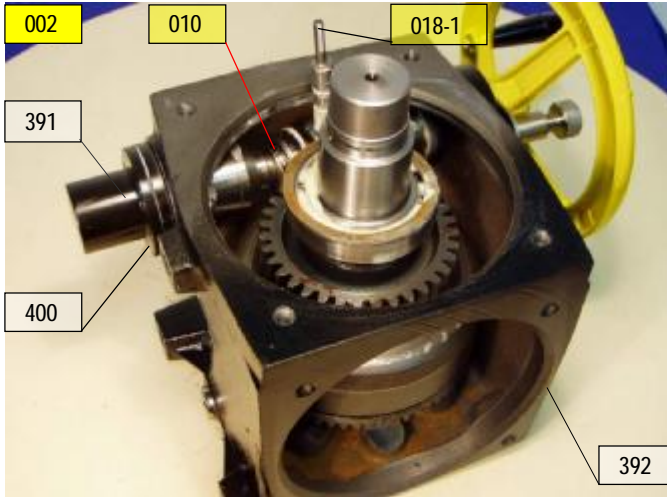

Poz.	Názov	PNm	Poznámky
002-72	PREVOD SILOVY Rusko	224564072	špec. text.
009-32	ZOSTAVA HRIADELA Rusko	224502532	špec. text.
010-XX	ZAVITOVKA ZOSTAVA	2245026XX	špec. text.
012-08	KOLESO RUCNE S VYREZO	224834608	
016-02	HRIADEL S ARETACIOU	224564202	
017-1	KLUKA ARETACIE	224A11101	
018-1	OVLADAC MOMENTOVY	224502701	
066-1	HRIADEL S PACKOU	224503101	
334	PODLOZKA	244511600	
335	PODLOZKA DISTANCNA	244517000	
340	LOZISKO 6008	663243024	
370-X	HRIADELKA	20463040X	špec. text.
371	SEGMENT	204630500	
372	PODLOZKA	204630600	
373	PUZDRO II S VLOZKOU-BEZOV	224581301	
374	KR_ZOKGUFERO 16X28X7	662735044	
375	KRUZOK POIST FE 28	663111801	
376	PERO 4X4X22	663152068	
377	PUZDRO II	204630302	
378	RUCNE KOLO /20DLO1010/	244731800	
379	PUZDRO KU 20X30	663243161	
380	SKRUTKA ARETACIE	204970600	
381	KRUZOK 20X16	662732063	
382	RAMENO ARETACIE	204970800	
383	MATICA ARETACIE	204970700	
384	KRUZOK 6.9X1.8	662732191	
385-X	KOLESO RUCNE	24473170X	špec. text.
386	CAP RUKOVATE	244732000	
387	KRUZOK FE 5	663112049	
388	RUKOVAT 8	663210015	
389	PODLOZKA DISTANCNA	244831900	
390	PODLOZKA DISTANCNA	244832000	
391	KRYTKA	204867700	
392-2	SKRINA MO D 102 Rusko	204764002	špec. text.
395-1	ZATKA	244833701	
396	KRUŽOK GUFERO 40X52X7 GP	662735043	
397	PODLOZKA BA 50 D 14X19X2	662732325	
398	SKRUTKA FE M 5X12-A2	663117040	
399	SKRUTKA FE M 4X12-A2	663117805	
400	SKRUTKA FE M 4X20-A2	663117809	
401	PODLOZKA FE M 5,5-A2	663117400	
403	KRUZOK 34X2	662732109	
405	PACKA	244514100	
406	UNASAC	244514300	
407	PODLOZKA	244840200	
408	KRUŽOK 10X6 MVQ	662732022	
409	KRUZOK FE 3,2	663111720	
455	PODLOZKA DISTANCNA	244831600	
456	PODLOZKA DISTANCNA	244831700	
672-2	HRIADEL M. J.	244514400	

# 005 Riadiaca skriňa a kryt riadiacej skrine

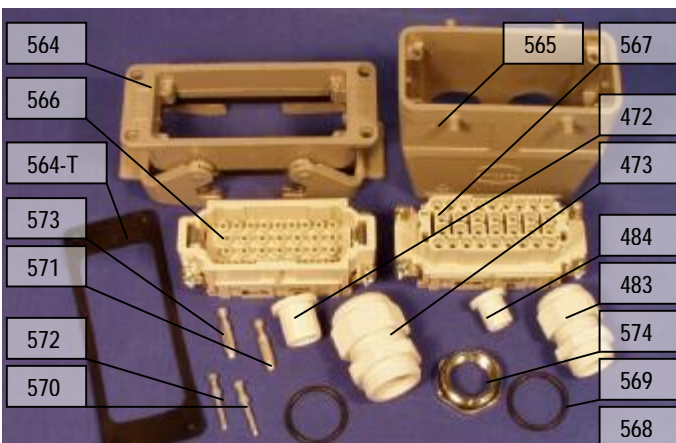
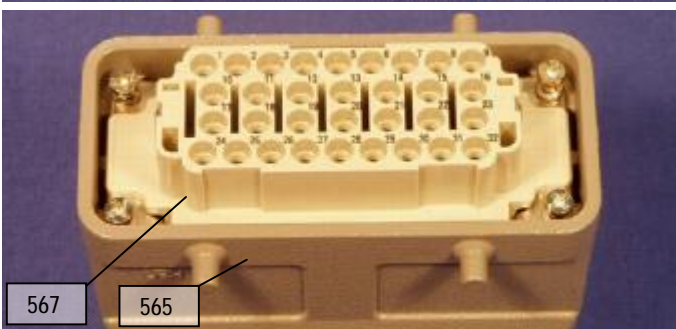
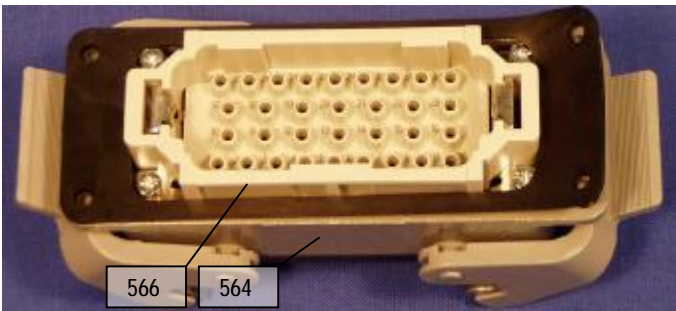
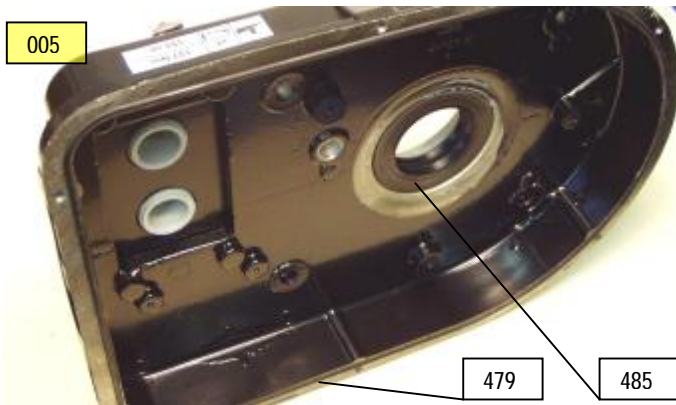
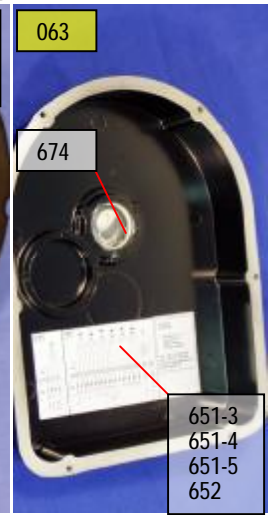
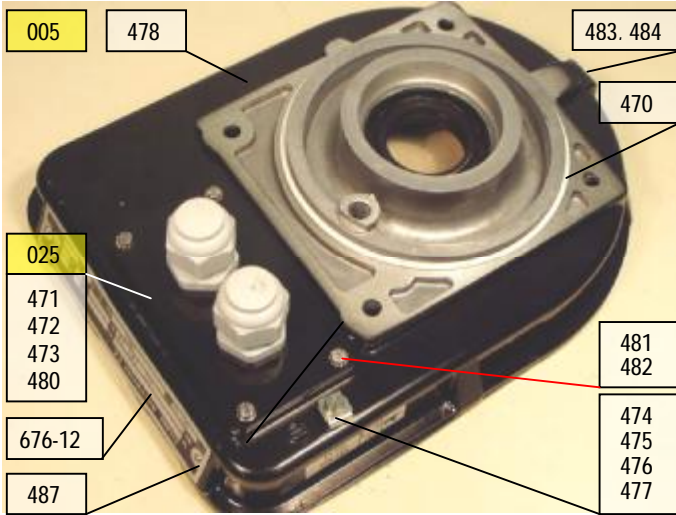

Poz	Názov	PNm	Poznámky
005-00	SKRINA RIADIACA-VYVODKY	224A21100	IP 65 52 000, 52 400.00
005-03	SKRINA RIADIACA-KONEKTOR	224A21103	IP 65 52 000, 52 400.00
005-21	SKRINA RIADIACA-VYVODKY	224A21121	IP 55 52 000, 52 400.00
005-24	SKRINA RIADIACA-KONEKTOR	224A21124	IP 55 52 000, 52 400.00
008-X	ZOSTAVA KONEKTOROV-HARTING	224A0020X	špec. textom
025-2	DOSKA S VYVODKAMI	224A20702	
041-X	SVORKOVNICA ZOSTAVA-S	224A0690X	špec. textom
063-2	KRYT RIADIACEJ SKRINE IP 65	224A21202	bez priezoru
470	KRUZOK 130X3	662732095	
471-2	DOSKA-OPRACOVANIE	204A01402	
472	OCHR.KRYTKA TESNIACA M25X1,5	663457028	
473	VYVODKA KÁBELOVÁ M 25X1,5	663457017	
474	PODLOZKA	244503400	
475	PODLOZKA	244532500	
476	PODLOZKA FE M 5	663117452	
477	SKRUTKA MS M 5X10	663118109	
478-00	SKRINA RIADIACA, 478-01 IP 55 KONEKT	204A78300,1	IP 55 VYVODKY
478-11	SKRINA RIADIACA	204A78312	IP 65 KONEKT-VYVO
479	TESNENIE RIADIACEJ SKRINE	604A05199	
480	TESNENIE DOSKY S VYVODKAMI	604A04799	ťaž pri konek. vyhot.
481	SKRUTKA FE M 4X12-A2	663117735	
482	PODLOZKA MS 4,3	663118624	
483	VYVODKA KÁBELOVÁ M 20X1,5	663457013	pri prepojení s motoro
484	OCHR.KRYTKA TESNIACA M20X1,5	663457025	pri prepojení s motoro
485	GUFERO GP 40X62X7	662735002	
487	RYH. KLINEC FE 2,49X4,76-NI	663111904	
564	KRYT PANELOVY HAN 16B	663456695	
564-T	KRYT PANELOVY HAN 16B	663456695	tesnenie súčasťou
565	TELESO KONEKT. M25 BOČNE	663456755	
566	ZASUVKA HAN 32 EE-M	663456713	
567	VIDLICA HAN 32 EE-F	663456712	
568	KRUZOK 22X2	662732046	
569	KRUZOK 20X2	662731034	
570	KOLIK 0.5 MM2	663456714	
571	DUTINKA 0.5 MM2	663456715	
572	KOLIK 1 MM	663456718	
573	DUTINKA 1 MM	663456719	
574	REDUKCIA RS-MSM25X1.5/M20X1.5	663457081	
575	SKRUTKA MS M 4X20	663118106	upevnenie konektora
576-X	STLPIK DISTANČNY MO-SVORKOVNICA	20495260X	03, 04
577	PLECH	204598400	
578-X	PLECH SVORKOVNICE	20495220X	01
579	SVORKOVNICA LTA 12-4 OP TXP310P	663456709	
580	MATICA FE M 4-ZN-8.8	663111542	
581	PODLOZKA FE 3,2-ZN	663111701	
582	SKRUTKA FE M 4X8	663111298	
583-12	STITOK SVORKOVNICE	204959612	
583-13	STITOK SVORKOVNICE	204959613	
583-14	STITOK SVORKOVNICE	204959614	
583-15	STITOK SVORKOVNICE	204959615	
651-3	SCHEMA ZAPOJENIA Z 298 spínače	244570403	651-4 Z 279A, -5 Z296
652	SCHEMA ZAPOJENIA Z 6A B2	204976400	
676-12	STITOK TYPOVY 52 000 (s naraz. údajmi)	244524112	nákup 644524112
656-3	VEKO-CIERNE	244532703	
657	TESNENIE	244532100	
658	SKRUTKA FE M 4X10-A2-70	663117804	
673	KRYT RIADIACEJ SKRINE BEZ PRIEZORU	244532000	
674	KRUZOK 43X35 MVQ	662732099	
675-1	STITOK REGADA 52 000	644540001	

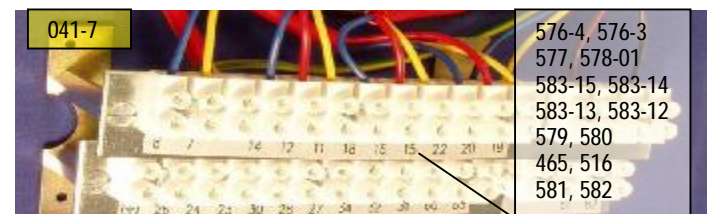

## 009-XX Zostava hriadeľa 224 5025 XX

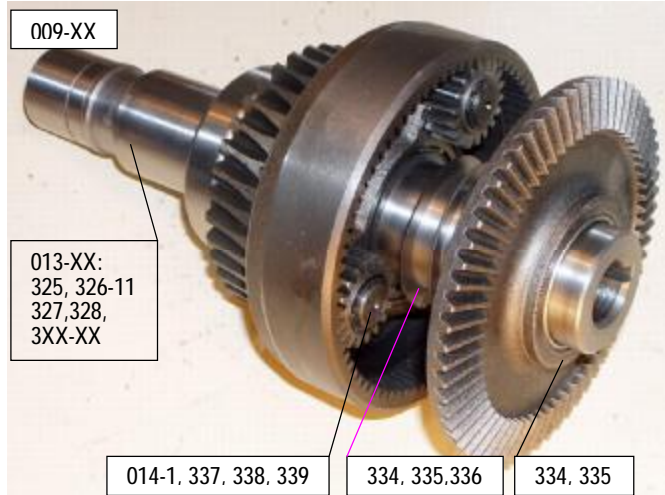

## 010-21 Závitovka zostava 224 5026 21(XX)

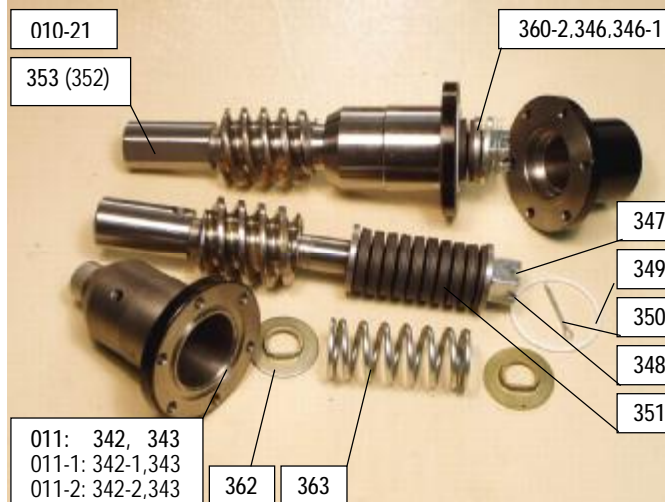

<b>009-XX</b>	Zostava hriadeľa	2245025XX	špecifikovať textom
<b>010-XX</b>	Závitovka zostava	2245026XX	špecifikovať textom
<b>011</b>	Puzdro s vložkou	224581400	
<b>011-1</b>	Puzdro s vložkou	224581401	
<b>011-2</b>	Puzdro s vložkou	224581402	
<b>013-XX</b>	Hriadeľ s unášačom	2245024XX	viď 013-XX
<b>014-1</b>	Satelit	224502901	
<b>015</b>	Koleso kuželové	224503000	
<b>3XX-XX</b>	Výstupný hriadeľ	2XXXXXX	viď 3XX-XX

<b>325-13</b>	Unášač 3 drážky	244511913	v 013-XX
<b>326-11</b>	Čap	244512011	v 013-XX
<b>327</b>	Kružok poistný FE 40	663111966	v 013-XX
<b>328</b>	Pero 8x7x20	663152070	v 013-XX

## 10-XX Závitovka zostava 224 5026 XX

List 1/1

<b>02</b>	341-1,345,346,347,348,349,350,352,354,355,356,357,359	
<b>03</b>	341-1,346,347,348,349,350,352,354,355,356,357,359	
<b>04</b>	341-1,346,347,348,349,350,352,354,355,356,358,359	
<b>05</b>	341-1,345,346,347,348,349,350,352,354,355,356,359	
<b>06</b>	341-1,346,347,348,349,350,352,354,355,356,359	
<b>07</b>	341-1,346,347,348,349,350,352,354,355,356,358,359	
<b>08</b>	341-1,345,346,347,348,349,350,352,354,355,356,359	
<b>10</b>	341-3,345,346,347,348,349,350,352,354,355,356,359	
<b>11</b>	346,346-1,347,348,349,350,353,359,360-3,011	
<b>12</b>	346,346-1,347,348,349,350,353,359,011,360-2	
<b>13</b>	346,346-1,347,348,349,350,353,359,011,360-2	
<b>14</b>	346,346-1,347,348,349,350,353,359,011,360-2	
<b>15</b>	346,346-1,347,348,349,350,353,359,011-1,360-2	
<b>16</b>	346,346-1,347,348,349,350,353,359,011,360-2	
<b>17</b>	346,346-1,347,348,349,350,353,359,360-3,011	
<b>18</b>	346,346-1,347,348,349,350,353,359,011,360-2,360-3	
<b>19</b>	346,346-1,347,348,349,350,353,360-3,011,361	
<b>20</b>	346,346-1,347,348,349,350,353,360-3,011,362,363	
<b>21</b>	346,346-1,347,348,349,350,351,353,360-2,011	
<b>22</b>	346,347,348,349,350,353,351,360-3,011	
<b>23</b>	347,348,349,350,353,011,360-2,362,364	
<b>24</b>	347,348,349,350,353,011,360-2,362,365	
<b>25</b>	347,348,349,350,353,011,360-2,368	
<b>26</b>	347,348,349,350,353,011,360-2,362,363,366	
<b>27</b>	347,348,349,350,353,360-3,011,367,369	
<b>28</b>	346,347,348,349,350,353,360-3,011	
<b>29</b>	346,347,348,349,350,351,353,360-3,011-2	
<b>30</b>	346,346-1,347,348,349,350,353,358,011-2	
<b>329</b>	Veniec	244512700
<b>330</b>	Satelit	204843100
<b>331</b>	Puzdro KU 1412	663243150
<b>332</b>	Koleso kuželové	244512200
<b>333</b>	Ložisko KU 40x30	663249037
<b>334</b>	Podložka	244511600
<b>335</b>	Podložka dištančná	244517000
<b>336</b>	Podložka	244517300
<b>337</b>	Podložka	244868901
<b>338</b>	Podložka	244868902
<b>339</b>	Kružok poistný FE 14	663111943
<b>340</b>	Ložisko 6008	663243024
<b>341</b>	Puzdro	244513600
<b>342-X</b>	Puzdro	20462960X
<b>343</b>	Puzdro KU 14x15	663243160
<b>344-2</b>	Rozperka	244508902
<b>345</b>	Podložka	244513300
<b>346</b>	Podložka s=0,2	244513400
<b>346-1</b>	Podložka s=0,3	244513401
<b>347</b>	Matica	244513500
<b>348</b>	Podložka	244538900
<b>349</b>	Kružok 3167 32x2	662732097
<b>350</b>	Zavlačka	663111756
<b>351</b>	Pružina TF 25x12,2x0,96x1,6	663152158
<b>352</b>	Závitkový hriadeľ	244512800
<b>353</b>	Závitkový hriadeľ	204867600
<b>354</b>	Zátka	244513700
<b>355</b>	Podložka dištančná	244832700
<b>356</b>	Podložka dištančná	244832800
<b>357</b>	Podložka upch. P21x20	662731060
<b>358</b>	Podložka	244519200
<b>359</b>	Pružina TF 25X12,2X0,7X1,6	663152071
<b>360-2</b>	Rozperka	244506902
<b>360-3</b>	Rozperka	244506903
<b>361</b>	Pružina TF 23X12,2X1,0	663152075
<b>362</b>	Podložka pre valcové pružiny	244891800
<b>363</b>	Pružina	644867100
<b>364</b>	PRUŽINA TL 3150X232X0480	663152189
<b>365</b>	PRUŽINA TL 2500X225X0530	663152191
<b>366</b>	RURKA VYMEDZOVACIA	204721300
<b>367</b>	PRUŽINA TL 3150X192X0500	663152190
<b>368</b>	PRUŽINA TL 2000X180X0530	663152192
<b>369</b>	Pružina 28X12,2X1,25 GR2	663152156

**Poznámka:** Dielce pre jednotlivé vyhotovenia závitovky sú rozpísané v hornej tabuľke ale nie sú všetky zobrazené.

XX	325-XX Unášač 244 5119 XX	326-11 Čap 244 5120 11	327 Kr. po 40	328 Pero 8x7x20	3XX-XX Výstupný hriadel'		Poznámky 1	Poznámky 2
01	12	+	+	+	301	244 5393 00	L=243,5 2P 4zu30 <sup>0</sup>	MO diera skrz Ø28
02	12	+	+	+	302	204 9243 00	L=180,6 2P, 2 zu14	T-C, koniec Ø30,3/17
03	12	+	+	+	303	244 5118 00	L=253,5 2P 4zu30 <sup>0</sup>	MO diera skrz Ø28
04	-							
05	12	+	+	+	304	244 5371 00	L=181 2P 4zu30 <sup>0</sup>	die skrz Ø28 koniec Ø30,3/17
06	12	+	+	+	305	244 5503 00	L=239,1 2P PØ25P8	MP plný
07	12	+	40,26, 32	+	306 307	244 6051 00 244 6052 00	L=247, MP-E L=262, Ø11 tyč	Základné vyhotovenie
08	-							
09	12	+	+	+	308	204 6140 00		Nemá výkres v systéme
10	-							
11	11	+	+	+	309	244 9468 00	L=243,5 4P 4zu30 <sup>0</sup>	MO diera skrz Ø28
12	12	+	+	+	310	244 5392 00	L=253,5 2P, 2 zu14	MO-Ex T-C diera skrz Ø28
13	13	+	+	+	311-28	204 A013 28	L=250,5 3P DØ25P8	diera, plný kon MO 3.5, kr.je.
14	12	+	+	+	305-01	244 5503 01	L=239,1 2PPØ252P8	MP závora plný s M8 a 2P8
15	12	+	+	+	313	204 8578 00	L=234,6 2P PØ25P8	MP plný, závit M4 na konci
16	11	+	+	+	314-01	244 9942 01	L=253,5 4P, 4zu45 <sup>0</sup>	MO-Ex T-C diera skrz Ø28
17	11	+	+	+	309-01	244 9468 01	L=253,5 4P 4zu30 <sup>0</sup>	MO-Ex diera skrz Ø28
18	11	+	+	+	315	204 8551 00	L=243,5, 4P, T-C	01: L=253,5, 4P, T-C
19	12	+	+	+	316	204 9125 00	L=220,6 2P, Ø25P8	MP plný ,koniec Ø30,3/17
20	12	+	+	+	310-01	244 5392 01	L=243,5 2P, 2 zu14	MO T-C diera skrz Ø28
21	11	+	+	+	317	204 9306 00	L=296,5 4P, Ø20P6	P-1103/02
22	11	+	+	+	315-01	204 8551 01	L=253,5, 4P, T-C	03 L=180,7 4P T-C, Ø30/17 04 L=243,5 4P T-C MO
23	11	+	+	+	317-01	204 9306 01	L=233,7 4P, Ø20P6	P-1103/02, T-C, Ø30/17
24	11	+	+	+	315-04	204 8551 04	L=243,5 4P, Ø15P5	MO,T-C Ø15H8
25	11	+	+	+	302-01	204 9243 01	L=180,6 4P, 4xzub	MO, 4xzub, CPT, Ø30/17
26	11	+	+	+	315-03	204 8551 03	L=180,7 4P, Ø20P6	MO,P-1103/03T-E,CPTØ30/17
27								
28								
29								
30								
31	Tri drážky 13	+	+	+	311-00	204 A013 00	L=243,5 3P 4xzub	MO, 4x45 Rusko
32	Tri drážky 13	+	+	+	311-01	204 A013 01	L=253,5 3P 4xzub	MO-Ex, 4x45 Rusko
33	Tri drážky 13	+	+	+	311-02	204 A013 02	L=243,5 3P 4xzub	MO-MT, 4x30 Rusko
34	Tri drážky 13	+	+	+	311-03	204 A013 03	L=243,5 3P Ø20P6	MO Mapol
35	Tri drážky 13	+	+	+	311-04	204 A013 04	L=253,5 3P Ø20P6	MO-Ex Mapol
36	Tri drážky 13	+	+	+	311-05	204 A013 05	L=180,7 3P Ø20P6	MO, CPT Ø30,3/17
37	Tri drážky 13	+	+	+	311-06	204 A013 06	L=243,5 3P Ø15P5	MO
38	Tri drážky 13	+	+	+	311-09	204 A013 09	L=180,7 3P 2 zu14	MOCPT+Kotúč 204A64600
39	Tri drážky 13	+	+	+	311-10	204 A013 10	L=180,7 3P 4zu45 <sup>0</sup>	MOCPT+Kotúč 204A64600
40	Tri drážky 13	+	+	+	311-11	204 A013 11	L=253,5 3P 4zu30 <sup>0</sup>	MO,MT-Ex 4x30
41	Tri drážky 13	+	+	+	311-12	204 A013 12	L=239,1 3P PØ25P8	MP plný hriadel'
42	Tri drážky 13	+	+	+	311-13	204 A013 13	L=239,1 3P PØ20,9P8	MP plný hriadel' 2x pero P8
43	Tri drážky 13	+	+	+	311-14	204 A013 14	L=228,6 3P PØ25P8	MP, MPR CPT, c
44	Tri drážky 13	+	+	+	311-15	204 A013 15	L=180,7 3P 4zu30 <sup>0</sup>	MO, MT CPT 4x30, Ø31/17
45	Tri drážky 13	+	+	+	311-16	204 A013 16	L=253,5 3P 2 zu14	MO-Ex drážka 14
46	Tri drážky 13	+	+	+	311-17	204 A013 17	L=243,5 3P 2 zu14	MO drážka 14
47	Tri drážky 13	+	+	+	311-18	204 A013 18	L=296,5 3P PØ20P6	Plný hriadel' 1103/02
48	Tri drážky 13	+	+	+	311-19	204 A013 19	L=233,7 3P PØ20P6	Plný hriadel' 1103/02, Ø30,3/17
49	Tri drážky 13	+	+	+	311-20	204 A013 20	L=234,6 3P PØ25P8	Plný hr. MPR, OV
50	Tri drážky 13	+	+	+	311-21	204 A013 21	L=244,5 3P 4zu45 <sup>0</sup>	MO 4x45 Rusko IP55
51	Tri drážky 13	+	+	+	311-22	204 A013 22	L=244,5 3P 4zu30 <sup>0</sup>	MO MT 4x30 Rusko IP55
52	Tri drážky 13	+	+	+	311-25	204 A013 25	L=244,5 3P 2 zu14	MO drážka 14
53	Tri drážky 13	+	+	+	311-26	204 A013 26	L=240,5 3P DØ25P8	MO 3.5 D25 diera s perom 8
54	Tri drážky 13	+	+	+	311-27	204 A013 27	L=177,7 3P DØ25P8	MO3.5P,diera s P8, Ø30,3/17
55	Tri drážky 13	+	+	+	311-29	204 A013 29	L=180,7 3P D20x20	Diera 20x20, Ø30,3/17
56	Tri drážky 13	+	+	+	311-30	204 A013 30	L=253,5 3P D20x20	MO-Ex Diera 14x14
57	Tri drážky 13	+	+	+	311-31	204 A013 31	L=339,5 3P PØ30P8	MO Plný hriadel'
58	Tri drážky 13	+	+	+	311-35	204 A013 35	Ø00-6,9-22,25-43	MO 25x25
59	Tri drážky 13	+	+	+	312	204 B093 00	L=214 3P DØ25P8	diera, plný kon MO 3.5, kr.je.
60	Tri drážky 13	+	+	+	311-36	204 A013 36	L=217,5 3P DØ20P6	Plný hr. MO 20/6 krok.j.
61	Tri drážky 13	+	+	+	311-42	204 A013 42	L=244,5 3P 2 zu14	MO vrtanie Ø29,2, dráž. 14
62	Tri drážky 13	+	+	+	311-43	204 A013 43	L=243,5 3P DØ22P6	MODiera ØD22, 2P6 Ma
63	Tri drážky 13	+	+	+	311-41	204 A013 41	L=293,5 3P 4zu30 <sup>0</sup>	MO,MT 4x30, krok.j.
64	Tri drážky 13	+	+	+	311-40	204 A013 40	L=293,5 3P 4zu45 <sup>0</sup>	MO,MT 4x45 krok.j.
99	Tri drážky 13	+	+	+	-	Bez hriadela		MO 3.3

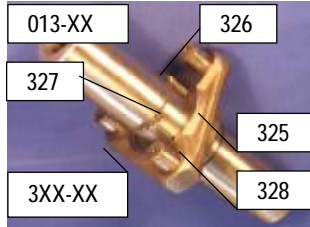

301 (L=243,5 2xP 4zu30°) 302 (L=180,6; 2xP; TVAR C) 303 (L=253,5 2xP 4zu30°)

--	--	--	--

304 (L=181 2P 4zu30°) 305 (L=239,1 2P PØ25P8) 306,307(L=247. MP-F. L=262. Ø11 tvč) 308(.....)

--	--	--	--

309 (L=243,5 4P 4zu30°) 310(L=253,5 2P, 2 zu14) 311-28 (L=250,5 3P DØ25P8) 305-01 (L=239,1 2PPØ252P8)

--	--	--	--

313 (L=234,6 2P PØ25P8) 314-01(L=253,5 4P, 4zu45°) 309-01(L=253,5 4P 4zu30°) 315 (L=243,5, 4P, T-C)

--	--	--	--

316 (L=220,6 2P, Ø25P8) 310-01(L=243,5 2P, 2 zu14) 317(L=296,5 4P, Ø20P6) 315-01 (L=253,5, 4P, T-C)



317-01 (L=233,7 4P, Ø20P6) 315-04 (L=243,5 4P, Ø15P5) 302-01 (L=180,6 4P, 4xzub) 315-03 (L=180,7 4P, Ø20P6)

			
--	--	--	---

311-00 (L=243,5 3P 4xzub) 311-01 (L=253,5 3P 4xzub) 311-02 (L=243,5 3P 4xzub) 311-03 (L=243,5 3P Ø20P6)

--	--	--	--

311-04 (L=253,5 3P Ø20P6) 311-05 (L=180,7 3P Ø20P6) 311-06 (L=243,5 3P Ø15P5) 311-09 (L=180,7 3P 2 zu14)

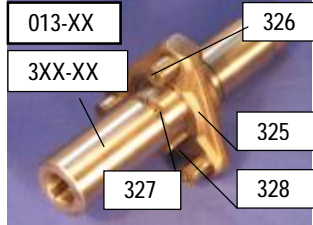

311-10 (L=180,7 3P 4zu45<sup>0</sup>) 311-11 (L=253,5 3P 4zu30<sup>0</sup>) 311-12 (L=239,1 3P PØ25P8)

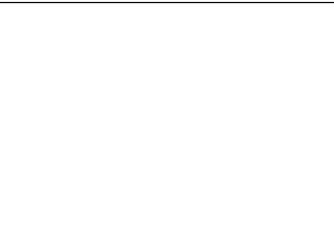
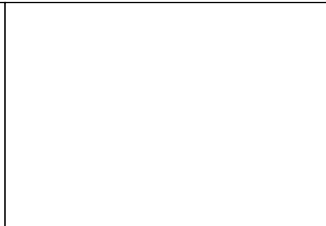
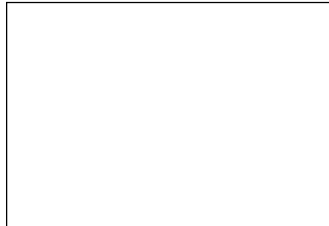

311-13 (L=239,1 3P PØ20,9P8) 311-14 (L=228,6 3P PØ25P8) 311-15 (L=180,7 3P 4zu30<sup>0</sup>) 311-16 (L=253,5 3P 2 zu14)



311-17 (L=243,5 3P 2 zu14) 311-18(L=296,5 3P PØ20P6) 311-19(L=233,7 3P PØ20P6) 311-20 (L=234,6 3P PØ25P8)

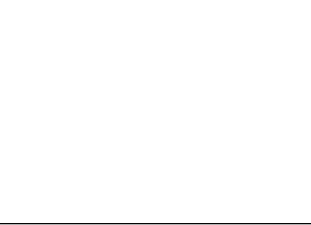
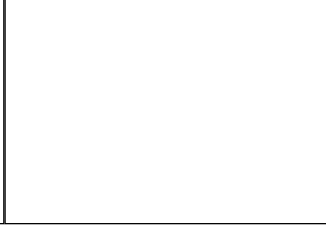

311-21 (L=244,5 3P 4zu45<sup>0</sup>) 311-22 (L=244,5 3P 4zu30<sup>0</sup>) 311-25(L=244,5 3P 2 zu14) 311-26 (L=240,5 3P DØ25P8)

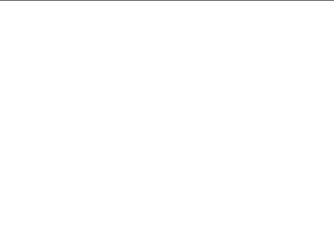
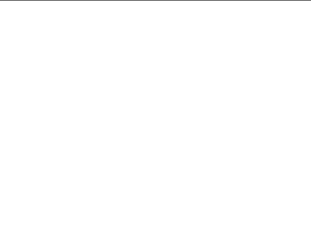

311-27 (L=177,7 3P DØ25P8) 311-29 (L=180,7 3P D20x20) 311-30(L=253,5 3P D20x20) 311-31 (L=339,5 3P PØ30P8)



311-35 (MO 25x25) 312 (L=214 3P DØ25P8) 311-36(L=217,5 3P DØ20P6) 311-42 (L=244,5 3P 2 zu14)

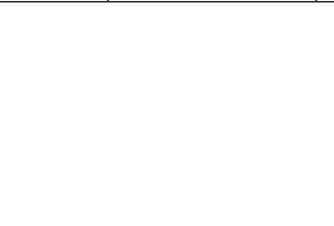
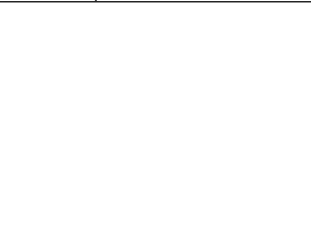
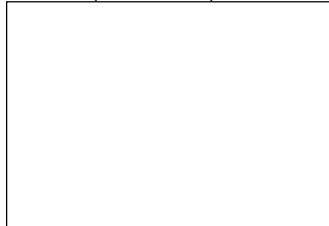

311-43 (L=243,5 3P DØ22P6) 311-41 (L=293,5 3P 4zu30<sup>0</sup>) 311-40 (L=293,5 3P 4zu45<sup>0</sup>) (.....)

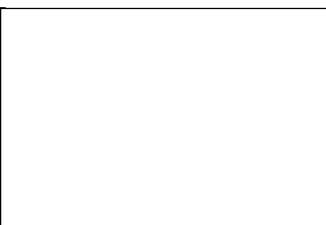

# 059 Elektrický servopohon MO 52 000

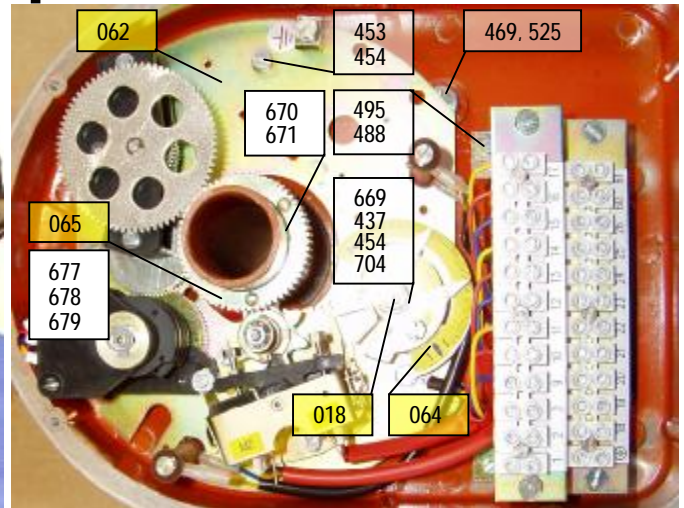
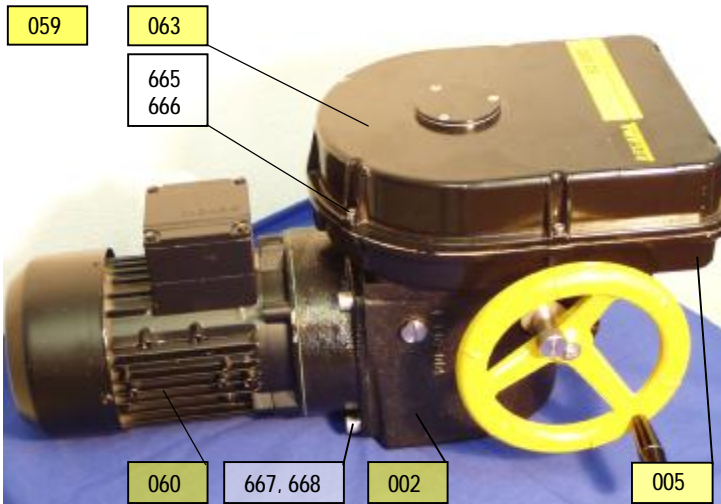

Poz	Názov	PNm	Poznámky
002-XX	SILOVY PŘEVOD	2245640XX	špec. text.
005-X	SKRINA RIADIACA	224A2110X	špec. text.
018-X	MOMENTOVY OVLADAC	22450270X	špec. text.
059-XX	EL. SERVOPOHON MO 52 000 s plyn.	2248715XX	špec. text.
060-XX	ELEKTROMOTOR-ZOSTAVA+ZDRZ	2245037XX	špec. text.
062-XX	OVLADACIA DOSKA s plynulým náhon.	2247439XX	špec. text.
063-X	KRYT RIADIACEJ SKRINE	224A2120X	špec. text.
064	MOMENTOVY VYPINACI KOTUC	224783600	
065	KOLESO OZUBENE	224506200	
437	PODLOZKA FE 5,3-ZN	663111691	
453	SKRUTKA FE M 5X10-ZN	663111207	
454	PODLOZKA FE 5-ZN	663111732	
469	SKRUTKA FE M 8X20-ZN-8.8	663111085	
488	PODLOZKA FE 3-ZN	663111729	
495	SKRUTKA FE M 3X8-ZN	663111163	
525	PODLOZKA FE 8-ZN	663111734	
665	SKRUTKA FEM 4x20-A2	663117130	
666	PODLOZKA M 4-A2	663117451	
667	SKRUTKA FEM 8x20-A2	663117170	
668	PODLOZKA M 4-A2	663117454	
669	MATICA FEM 5	663111545	
670	POISTNY KRUIZOK	644834100	
671	PERO 3H9x3x6	663152038	
677	KOLESO OZUBENE	244512500	
678	IHLOV. VALCEK 4X23,8 B5	663249104	
679	ŠTIFOK O - Z	604A10500	
704	MATICA FEM 5-YN-8.8	663111544	
705	VLOZKA	204952700	
XXX	OLEJ PŘEVODOVY PP 80	661112034	
XXX	MAZACI TUK GLEIT HP 571-2	661112055	
XXX	MAZACI TUK GLEIT HF 401/0	661112055	

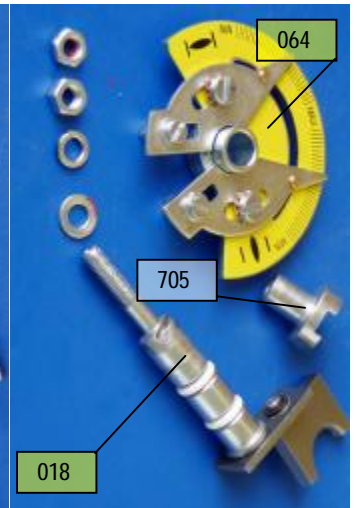
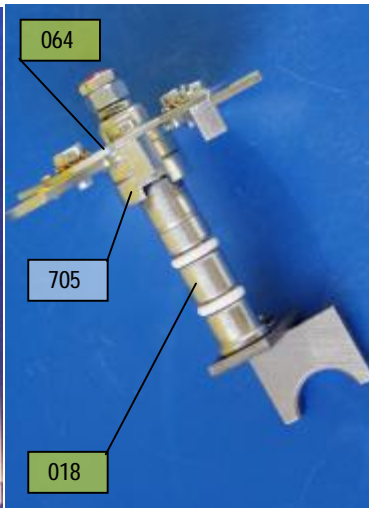
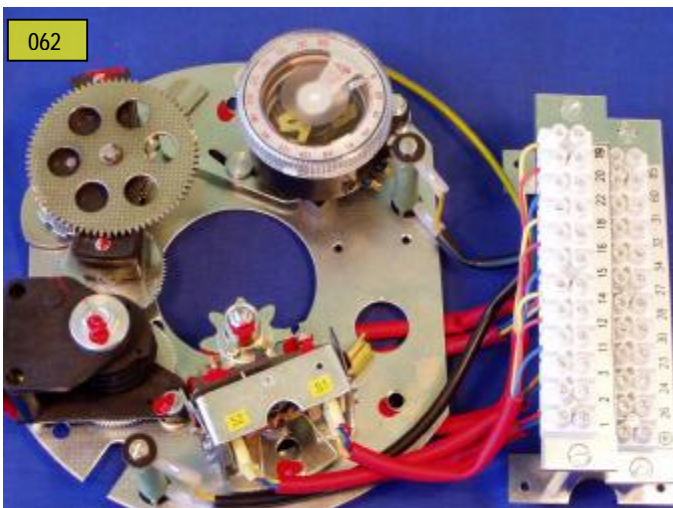



# 060 Otočná zdrž + Elektromotor ES 52 000

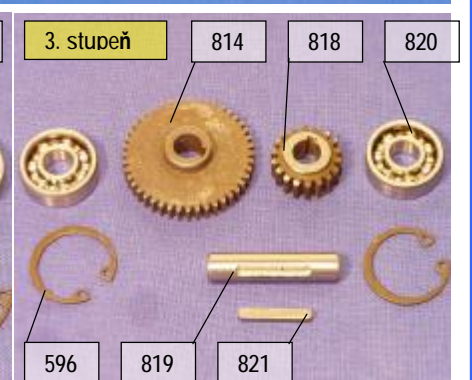
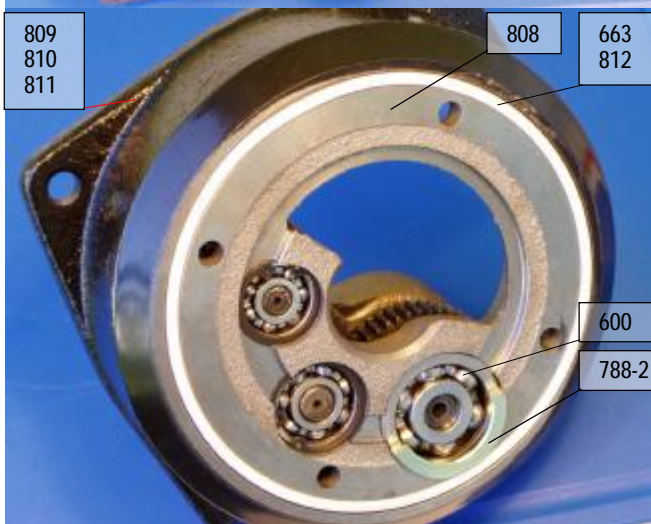
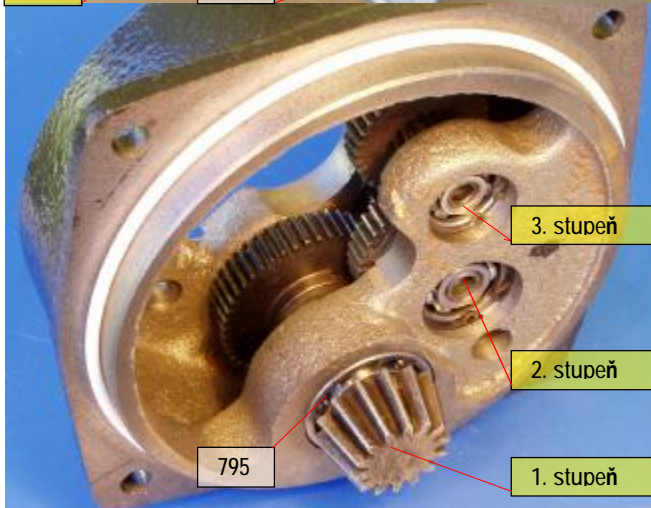
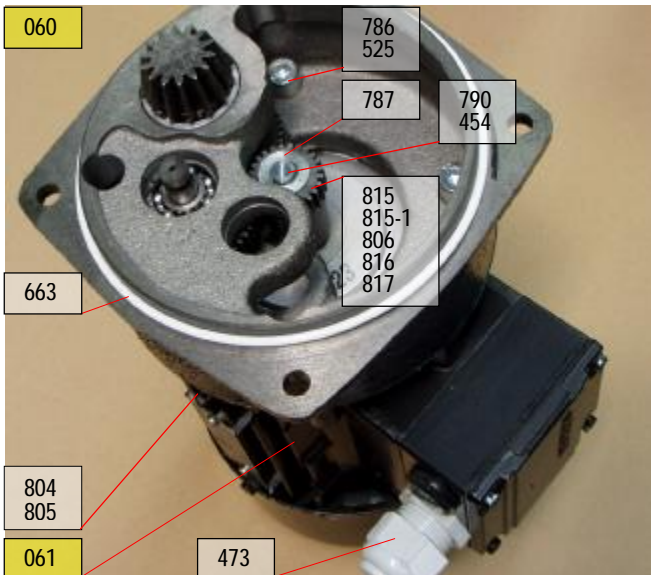

Poz.	Názov	PNm	Poznámky
060-72	OTOČNÁ ZDRŽ + ELEKTROMOTOR	224503772	R: 25 ot/min
060-XX	OTOČNÁ ZDRŽ + ELEKTROMOTOR	2245037XX	Špec. textom
061-XX	MOTOR	2245096XX	Špec. textom
061-64	MOTOR 380/220, 250W	224509664	pre RUSKO
429	LOZISKO 6000	663243023	
473	VYVODKA KÁBELOVÁ M 25X1,5	663457017	
525	PODLOŽKA FE 8-ZN	663111734	
663	KRUŽOK 125X3	662732115	pre MEDZIP.810
785	KOLESO OZUBENÉ	244515900	R: 25 ot/min
786	SKRUTKA FE M8X25-ZN-8.8	663111395	
787	PODLOŽKA	244516300	
788	PODLOŽKA	244515100	
789	KOLESO OZUBENÉ	244516600	
790	SKRUTKA FE M5X18-ZN	663111213	
791	PASTOROK KUŽELOVÝ	244515000	
792	PERO 4X4X16	663152056	
793	KRUŽOK	244515200	
794	VYRAŽAC	244515300	
795	LOZISKO 6300	663249039	
796	KLUČ	224515400	
797	VALCEK	224515500	
798	PRUŽINA	224515600	
799	PUZDRO PRUŽINY	224515700	
800	ČAP	224516900	
801	PERO 3X3X28	663152069	
802	KRUŽOK POISTNÝ FE 26	663111773	
803	KOLESO OZUBENÉ	244515800	R: 10,16,63 ot/min
804	PODLOŽKA D 10/D 6,2	204954302	pod upev.sk.priř. M
805-27	MOTOR 1LA7070-4AB93-Z.380/220,250W	663592427	pre RUSKO
805-XX	MOTOR (typ, napätie, výkon špecifikovať text.)	XXXXXXX	Špec. textom
806	PASTOROK	244946200	25 ot/min
807	PASTOROK	244516800	pre 16,25,40 ot/min
808	TESNENIE (nezobrazené)	604964700	pre MEDZIP.811
809-X	MEDZIPRIRUBA	24451460X	pre 16,25 ot/min
810-X	MEDZIPRIRUBA	24451470X	pre 10,40,63 ot/min
811-10	MEDZIPRIRUBA-PLOCHE TESNENIE (nezobr.)	244514710	pre RUSKO
812	KRUŽOK 3167 110X3 MVO	662732128	pre MEDZIP.809
813	PASTOROK	244518000	R: 10,16 ot/min
814	KOLESO OZUBENÉ	244516700	40 ot/min
815-X	PASTOROK 815-1 pre R:16 ot/mi	24451830X	10 ot/min
816	PASTOROK	244931600	40 ot/min
817	PASTOROK	244514800	63 ot/min
818	PASTOROK	244518100	
819	ČAP	244518200	
820	LOZISKO 608	663243030	
821	PERO	204966901	

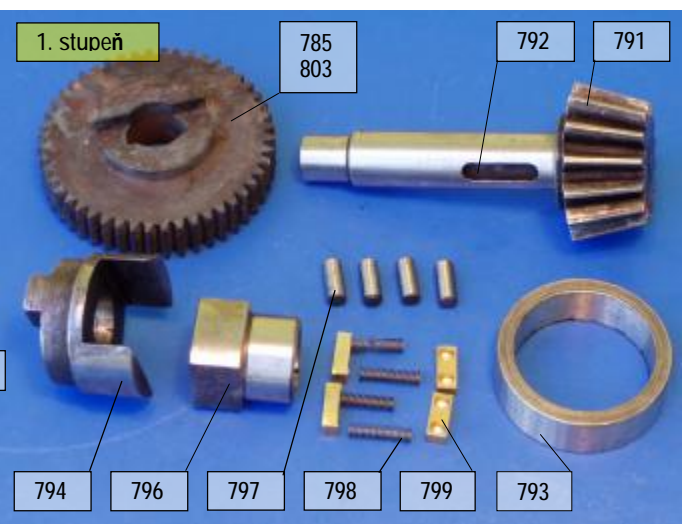

# 062 Ovládací doska MO s plyn. náhonom

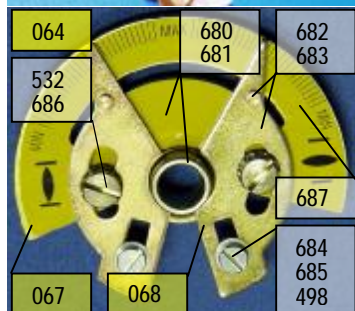
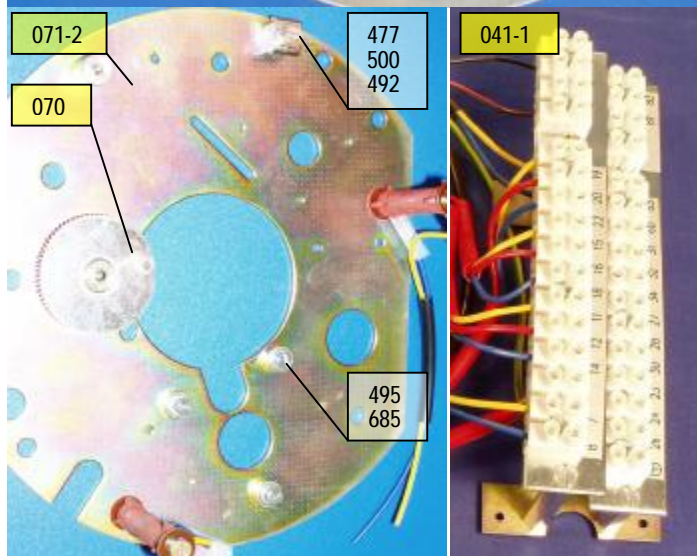
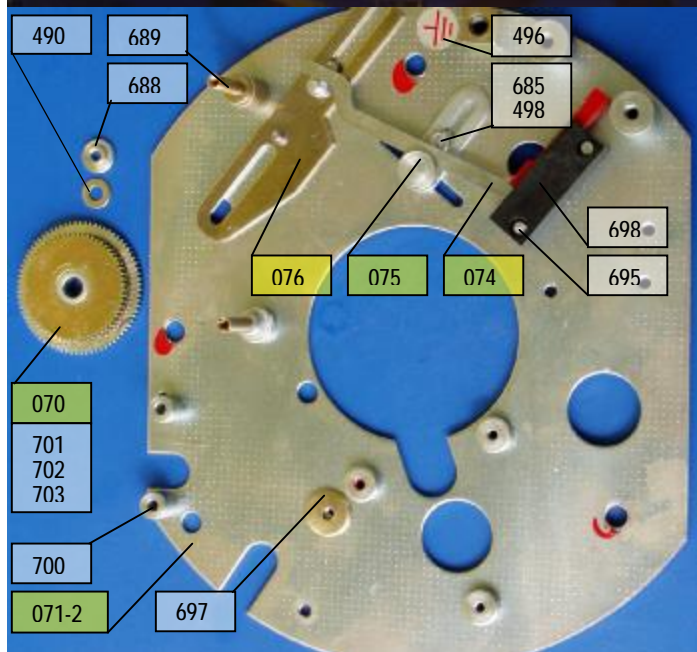
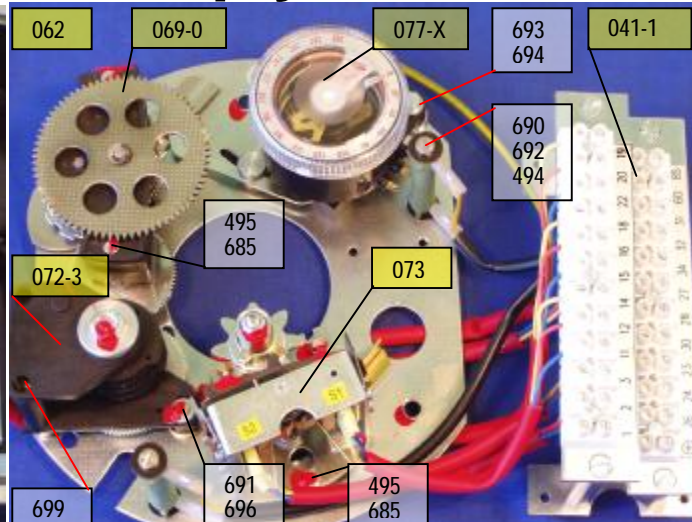

Poz	Názov	PNm	Poznámky
041-1	SVORKOVNICA ZOSTAVA	224A06901	
062-XX	OVĽADACIA DOSKA s plynulým náhon.	2247439XX	špec. text.
064	MOMENTOVÝ VYPINACÍ KOTUČ	224783600	
067	DOSKA S PUZDROM	224783700	
068	DORAZ S KOLIKOM	224783800	
069-0	PREVODOVKA	224544801	s vysielateľom
070	PUZDRO S KOLESAMI	224741700	
071-2	DOSKA OVĽADACIA S CAPMI	224741802	
072-3	JEDNOTKA P-S	224743603	
073	MOMENTOVA JEDNOTKA	224743700	
074	PAČKA	224501700	
075	DRŽIAK ČAPU	224501100	
076	TIAHLO	224501400	
077-X	VYSIELAČ ZOSTAVA	22450380X	špec. text.
477	SKRUTKA MS M 5X10	663118109	
490	PODLOZKA FE 3,2-ZN	663112310	
492	PODLOZKA	204784200	pod zem. skrutku
494	PODLOZKA IZOLACNA	244805600	
495	SKRUTKA FE M 3X8-ZN	663111163	
496	STITOK	644601262	
498	SKRUTKA FE M 3X6 ZN TVAR A	663111160	
500	PODLOZKA FE 5,3	663111704	
532	SKRUTKA FE M 4X6-ZN	663111839	
680	DOSKA	204899300	
681-1	PUZDRO	244506301	
682	DORAZ	204899400	
683-2	CAP	204955602	
684	DORAZ	244506200	
685	PODLOZKA B FE 3,2 ZN	663111688	
686	PODLOZKA FE 4,3 ZN	663111712	
687	NALEPKA MJ	604951200	
688	CAP	244508200	
689	STLPOK	244510100	
690	SKRUTKA M4X50-A2-70	663117020	
691	SKRUTKA FE M3X16-ZN	663111170	
692	ODPOR TR 616 12 k Ohm	663711007	
693	SKRUTKA FE M4X14-ZN	663111192	
694	PODLOZKA B FE 4,3 ZN	663111690	
695	SKRUTKA FE M2X12-ZN	663112357	
696	PODLOZKA 3,2 A2	663118600	
697	PODLOZKA	204956300	
698	LOZISKO	244506500	
699	SKRUTKA FE M3X35 - ZN	663111179	
700	DISTANČNÝ STLPIK	204950100	
701	PUZDRO MO	204777602	
702	KOLESO OZUBENE MO	204777700	
703	KOLESO OZUBENE MO	204777800	

# 041,069, 071, 074÷077 Jednotky ovl. dosky

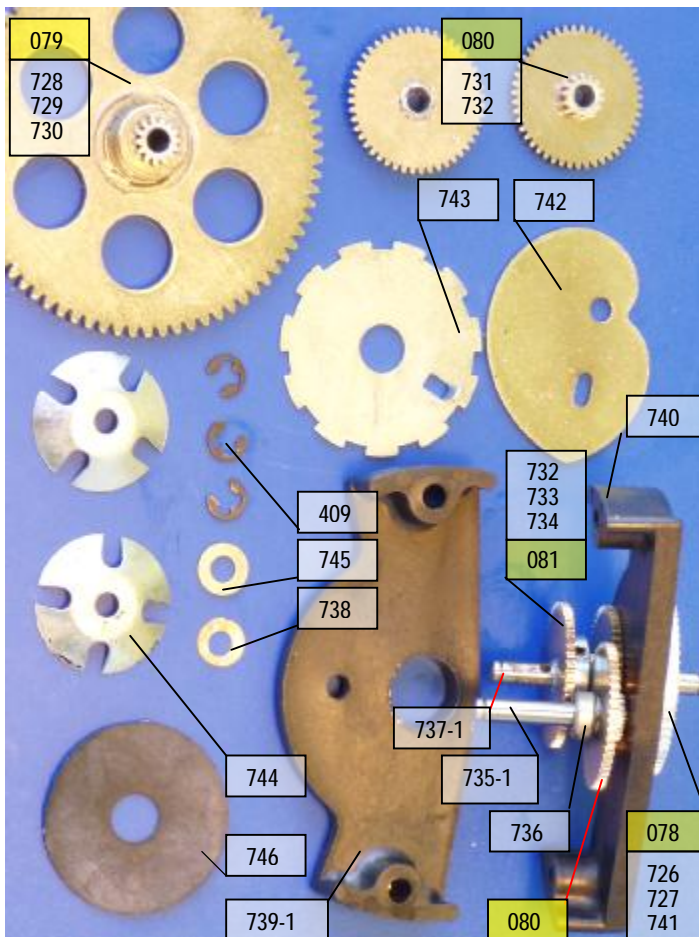
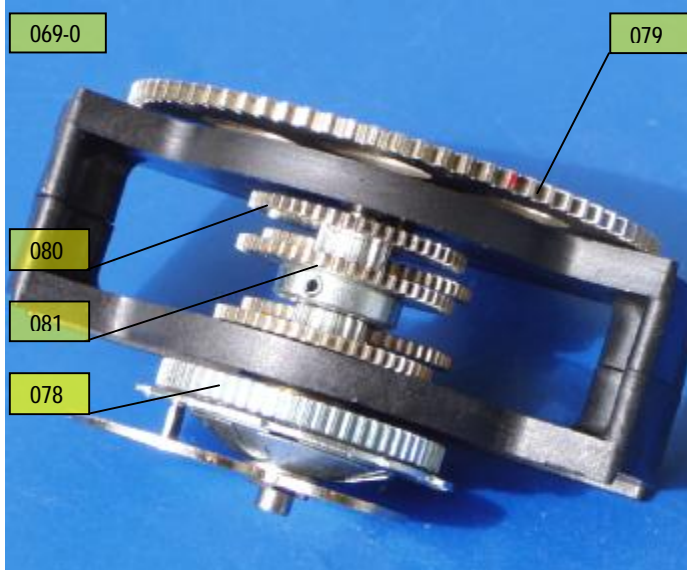
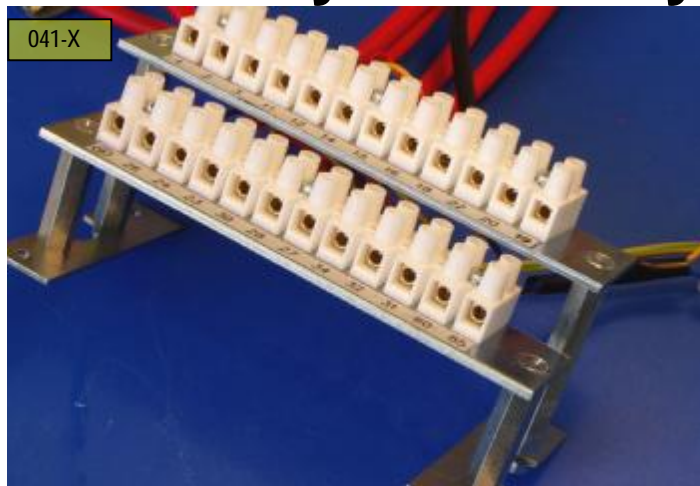
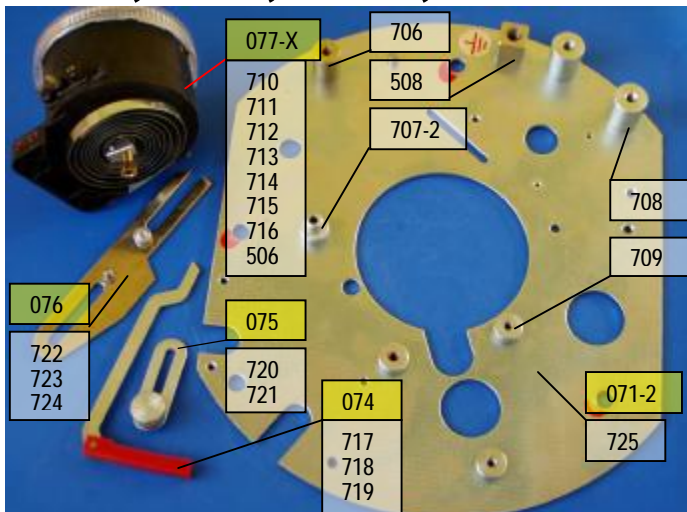

Poz	Názov	PNm	Poznámky
041-X	SVORKOVNICA ZOSTAVA	224A0690X	Spec. textom
069-0	PREVODOVKA	224544800	s vysielacom
069-1	PREVODOVKA	224544801	bez vysielaca
071-2	DOSKA OVLADACIA S CAPMI	224741802	
074	PAČKA	224501700	
075	DRŽIAK ČAPU	224501100	
076	TIAHLO	224501400	
077-X	VYSIELAČ ZOSTAVA	22450380X	Spec. textom
078	KOLESO ZOSTAVNÉ	224501900	
079	KOLESO NAHONOVÉ	224502000	
080	DVOJKOLESO	224544500	
081	KOLESO PRESTAVNÉ	224544600	
409	KRUŽOK FE 3,2	663111720	
506	PODLOŽKA B FE 2,2	663111686	
508	STLPIK ZEMNENIA	204784100	
706	ČAP	244508400	
706	ČAP	244508400	
707-2	ČAP	204777402	
708	ČAP	244509200	
709	ČAP	244509000	
710-1	VYSIELAČ SO STUP. 1X100 Ohm T2	244518701	664051048
710-2	VYSIELAČ SO STUP. 2X100 Ohm T2	244518702	664051047
710-3	VYSIELAČ SO STUP. 1X100 Ohm TH2	244518703	664051048
710-4	VYSIELAČ SO STUP. 2X100 Ohm TH2	244518704	664051047
710-5	VYSIELAČ SO STUPNICOU	244518705	664051045
711	SKRÚTKA B FE M 2X5	663111148	
712	PRUZINA	644517900	
713	SKRÚTKA B FE M 2X6	663111149	
714	KOTVA	244510200	
715	PASTOROK	244510600	
716	PODLOŽKA	244531200	
717	PAKA	244508000	
718	TYČKA HREBEŇOVÁ	644506400	
719	KOLIK	663111453	
720	DRŽIAK	244507100	
721	ČAP	244507200	
722	TIAHLO VYSIELAČA	244507900	
723	KOLIK	244508500	
724	KOLIK	244508900	
725	OVLADACIA DOSKA	244529300	
726	KOLESO OZUBENÉ	244509500	
727	PUZDRO	244510900	
728	PASTOROK	244509800	
729	PUZDRO	244510300	
730	KOLESO OZUBENÉ	244529500	
731	PASTOROK	244534500	
732	KOLESO OZUBENÉ	244841700	
733	NABOJ	244534700	
734	KOLIK FE 2X14	663112430	
735-1	OSKA	244509701	
736	KRUŽOK ROZPERNÝ	244510400	
737-1	OSKA	244511001	
738	PODLOŽKA	244511100	
739-1	ČELO VRCHNE	244518501	
740	ČELO SPODNE	244518600	
741	KOLIK FE 2X10	663111951	
742	EXCENTER	244508800	
743	KOTÚČ VAČKOVÝ	244509300	
744	PERO DISKOVÉ	244509900	
745	PODLOŽKA	244510500	
746	PODLOŽKA	244530200	

# 072÷073 Polohová a momentová jednotka

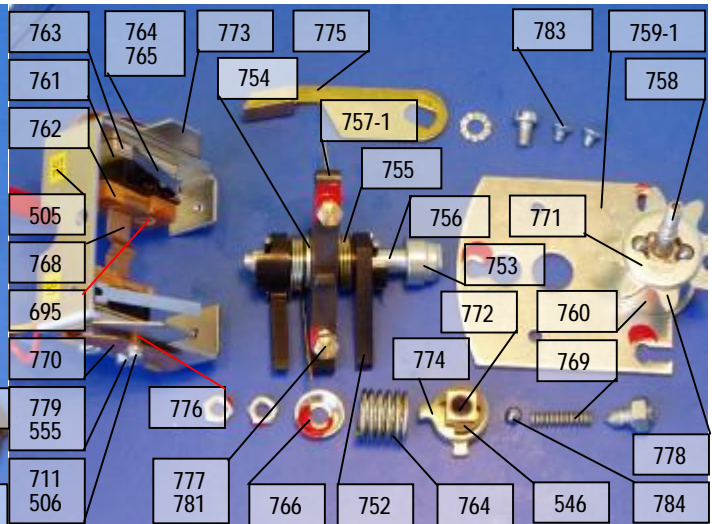
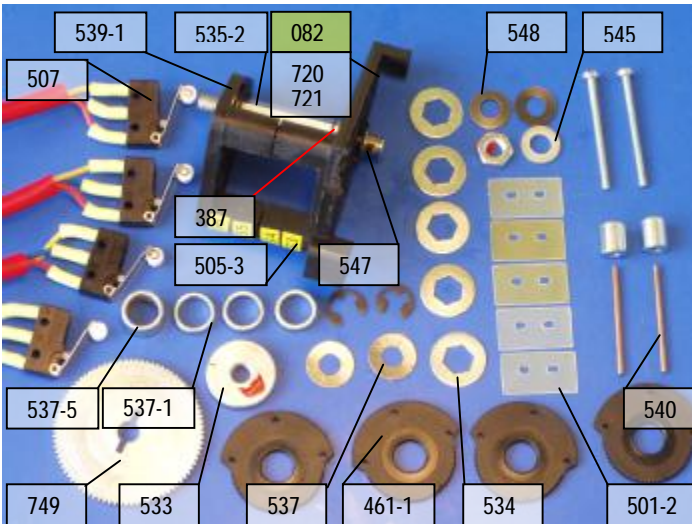
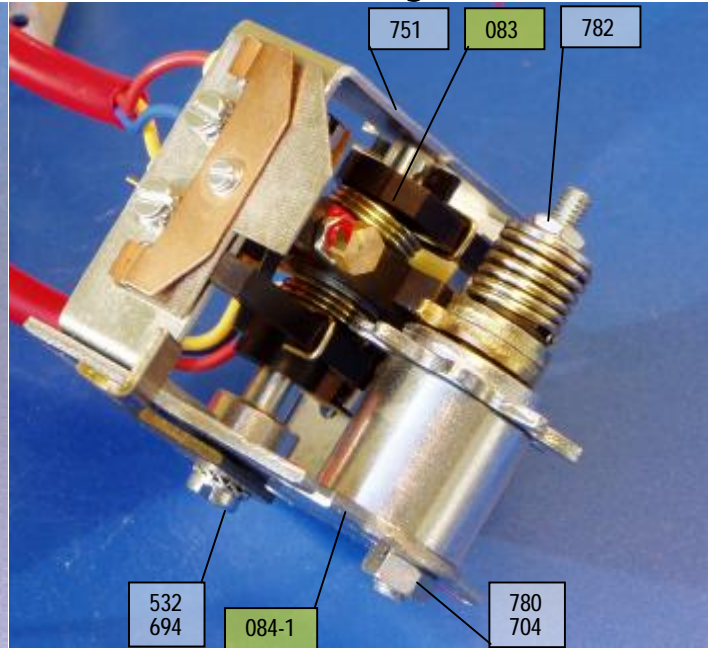
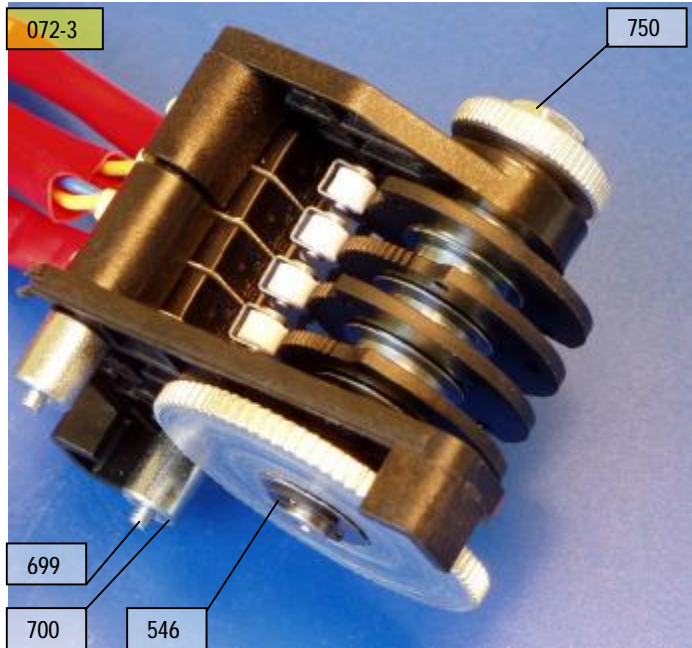

Poz.	Názov	PNm	Poznámky
072-3	JEDNOTKA P-S	224743603	
082	KOSTRA JPS	224742000	
387	KRUZOK FE 5	663112049	
461-1	VACKA	604746101	
505-3	STITOK OZNAC. MSP S3, S4: 505-4	60468090X	S5: 505-5, S6: 505-6
507	MIKROSPINAC DB 6G-B1 RB	664051220	
533	MATICA RYHOVANA M6	204660000	
534	PODLOZKA TRECIA	204661200	
535-2	HRIADEL J.P-S	204709302	
537	PODLOZKA DISTANCNA	244853900	
537-1	PODLOZKA DISTANCNA	244853901	
537-5	PODLOZKA DISTANCNA	244853905	
539-1	UZAVER JPS	204709701	
540	TYCKA MSP	204709800	
545	PODLOZKA FE 6,4-ZN	663111692	
546	KRUZOK FE 6	663111723	
547	KOLIK FE 2X12	663111967	
548	PRUZINA 12.5X6.2X0.5X0.85	663152112	
699	SKRUTKA FE M3X35 - ZN	663111179	
700	DIŠTANČNÝ STLPIK	204950100	
747	KOSTRA JPS MO	204779900	
748	PUZDRO KU 8X6X8	663243118	
749	KOLESO (360)	204715700	
750	MATICA FE M6	663111550	
073	MOMENTOVA JEDNOTKA	224743700	
083	ZOSTAVA PAČKY	224500600	
084-1	DOSKA MOMENTOVEJ JEDNOTKY	224500700	
085	ZOSTAVA SPINAČOV	224744000	
505-1	STITOK OZNAC. MSP	604680901	
506	PODLOZKA B FE 2,2	663111686	
532	SKRUTKA FE M 4X6-ZN	663111839	
546	KRUZOK FE 6	663111723	
555	PODLOZKA FE 3,2-ZN	663111710	
686	PODLOZKA FE 4,3 ZN	663111712	
694	PODLOZKA B FE 4,3 ZN	663111690	

Poz.	Názov	PNm	Poznámky
704	MATICA FEM 5-YN-8.8	663111544	
711	SKRUTKA B FE M 2X5	663111148	
751	NOSNIK VYPINAČOV	204541900	
752	PAKA VYPINACIA	244504200	
753	HRIADELKA	244504300	
754	PODLOZKA	244529700	
755	PRUZINA	644503600	
756	KOLIK FE 2X10	663111455	
757	PAČKA	204540700	
758	OS	244503900	
759	DOSKA MOMENTOVEJ JEDNOTKY	244504400	
760	ROZPIERKA	244503700	
761	DOSKA IZOLAČNA MO	204778100	
762	DOSKA MO	204778200	
763	PLECH MO	204778300	
764	MIKROSPINAC DB 6G-B1 BA BEZ PAČKY	664051219	
765	ZUSATZBETATIGER 6141273 PAČKA	664051415	
766	PODLOZKA	244503800	
767	PRUZINA	644504500	
768	PERO	244504600	
769	PRUZINA	644504700	
770	PERO	244504800	
771	VODITKO	244504900	
772	LOŽISKO	244505200	
773	ZARÁŽKA	244505300	
774	VACKA	244505400	
775	PAČKA	244505500	
776	ROZPIERKA	244505600	
777	SKRUTKA	244917800	
778	PASTOROK	244946600	
779	SKRUTKA FE M3X5	663111159	
780	SKRUTKA FE M5X12-ZN	663111882	
781	MATICA FE M3-ZN	663111538	
782	MATICA FE M4-ZN	663111543	
783	SKRUTKA FE M3X4-ZN	663111959	
784	GULIČKA	663249013	