

# ***DMS3***

**Setup of parameters  
using buttons control unit**

**Menu LED**

**Register errors and warnings**

**Appendix  
74 1053 02**

## 1. Table of contents

1.	TABLE OF CONTENTS .....	2
2.	PARAMETERS SETUP .....	3
3.	SETUP OF PARAMETERS USING BUTTONS CONTROL UNIT .....	4
3.1.	USED SYMBOLS FOR LED INDICATION .....	5
3.2.	MENU LED - ENTER THE MENU AVAILABLE WITHOUT PASSWORD .....	5
3.3.	MENU LED - ENTER THE MENU PROTECTED PASSWORD .....	5
3.4.	MENU LED - OPTION MENU AND PARAMETERS .....	6
3.5.	MENU LED - CHANGE AND RECORD OF PARAMETERS .....	7
3.6.	MENU LED – INACCESSIBLE PARAMETER .....	8
3.7.	MENU LED – TEMPORARY INACCESSIBLE PARAMETER .....	8
3.8.	MENU LED - MENU EXIT .....	8
3.9.	PARTICULAR PARAMETERS SETUP .....	9
3.9.1.	<i>Limit position C setup</i> .....	9
3.9.2.	<i>Limit position "O" setup</i> .....	9
3.10.	REGULATOR CALIBRATION .....	10
3.11.	MENU .....	11
3.11.1.	<i>MENU 1 – Torque</i> .....	11
3.11.1.1.	MENU 1 – Torque C .....	11
3.11.1.2.	MENU 1 – Torque O .....	12
3.11.2.	<i>MENU 2 – End position</i> .....	13
3.11.3.	<i>MENU 3 – Torque blockage</i> .....	14
3.11.3.1.	MENU 3 – Time setup for torque blockage .....	14
3.11.3.2.	MENU 3 – Setup position for torque O blockage .....	15
3.11.3.3.	MENU 3 – Setup position for torque C blockage .....	15
3.11.4.	<i>MENU 4 – Relay READY</i> .....	16
3.11.5.	<i>MENU 5 – Relay 1 .. 5</i> .....	17
3.11.5.1.	MENU 5 – Relay 1..5 .....	17
3.11.5.2.	MENU 5 – Position Relay 1..5 .....	18
3.11.6.	<i>MENU 6 – CPT</i> .....	19
3.11.7.	<i>MENU 7 - Regulation, Analog control signal</i> .....	20
3.11.7.1.	MENU 7 – Regulation .....	20
3.11.7.2.	MENU 7 – Analog control signal .....	21
3.11.8.	<i>MENU 8 – Dead zone</i> .....	22
3.11.9.	<i>MENU 9 – Failure</i> .....	23
3.11.9.1.	MENU 9 - Failure reaction .....	23
3.11.9.2.	MENU 9 – Safe position .....	24
4.	REGISTER ERRORS AND WARNINGS .....	25
5.	SYSTEM DMS3 - ELECTRONIC CONTROL SYSTEM FOR CONTROLLING THE ELECTRIC ACTUATORS (NEXT EA) - THE BASIC FEATURES AND OPTIONS .....	28

## 2. Parameters setup

Menu	Parameter	Button	Blink		Parameters value	
			PAR	SEL		
	Position C	C			Setup the actual position as the C limit position	
	Position O	O			Setup the actual position as the O limit position	
	Calibration controller	P			Start the calibration controller	
1	Torque	C		1	Torque C	
		O		2	Torque O	
		P	5-10		50-100 % (by 10 %),(50 and 60% depend on par. Torque min.)	
2	End position	P	1		Torque O + Torque C	
			2		Torque C + Position O	
			3		Position C + Torque O	
			4		Position O + Position C	
3	Torque blockage	C			Setup the actual position for torque C blockage	
		O			Setup the actual position for torque O blockage	
		P	0-20		Time set-up for Torque blockage	
		C+O			Default setup of time and position blockage	
4	Relay ready	P	1		Errors	
			2		Errors or warning	
			3		Errors or not remote control	
			4		Errors or warning or not remote control	
5	Relay 1 - 5	C,O		1-5	Relay 1 - 5 selection, setup the actual position in parameter position Relyay 1..5	
		C+O			Default setup of Relay 1 - 5 functions and positions	
		P	1		Disabled	
			2		Position O	
			3		Position C	
			4		Torque O	
			5		Torque C	
			6		Torque O or Torque C	
			7		Torque O or Position O	
			8		Torque C or Position C	
			9		Open	
			10		Close	
			11		Move	
			12		Move – blink / Move - twinkler	
			13		To position	
			14		From position	
			15		Warning	
			16		Control – remote	
17			Control – local			
18		Control – off				
6	CPT transmitter	P	1		4-20 mA	
			2		20-4 mA	
7	Control, Analog control signal	C		1	Control	
		P	1	1	2P	
			2	1	3P	
			3	1	3P/2P I2	
		O		2	Analog control signal	
		P	1	2	4-20 mA	2-10 V
			2	2	20-4 mA	10-2 V
			3	2	0-20 mA	0-10 V
			4	2	20-0 mA	10-0 V
			5	2	4...12 mA	-
6	2		12...20 mA	-		
7	2		20...12 mA	-		
8	2		12...4 mA	-		
8	Dead zone	P			1 % to 10 % (by 1 %)	
9	Failure reaction	C,O			Setup the actual position (Open, Close)	
		P	1		Open	
			2		Close	
			3		Stop	
4			Safe position			

### 3. Setup of parameters using buttons control unit

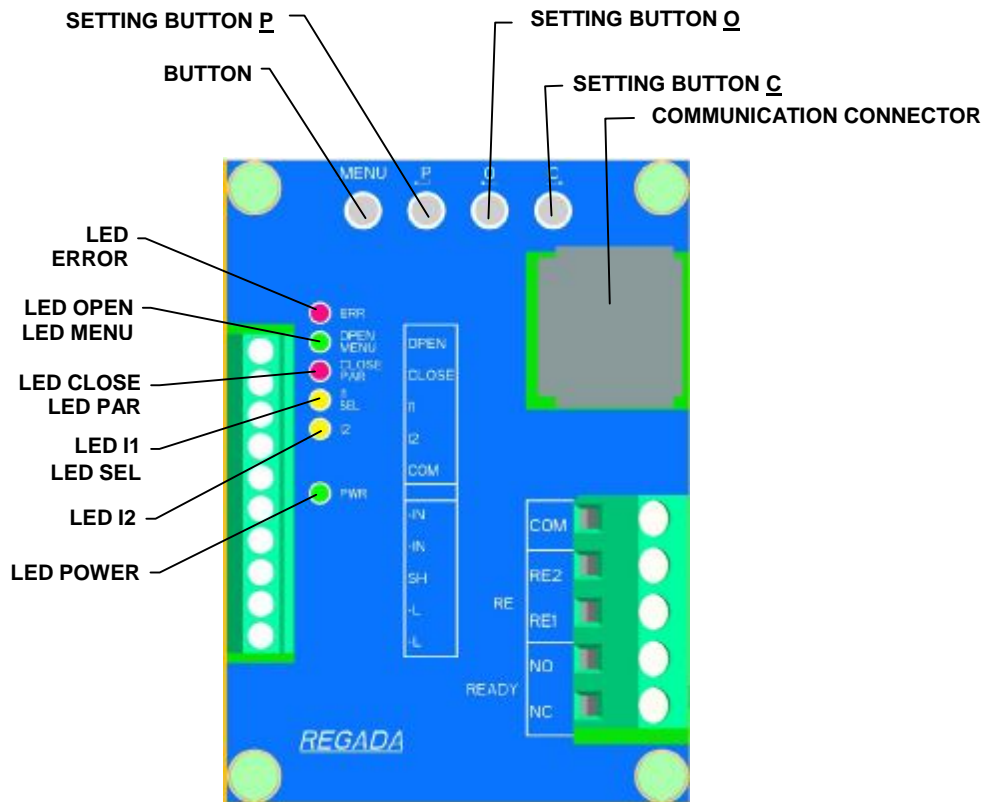

**Control unit with setup buttons**

#### MENU LED



- Menu will prevent EA normal operation.
- If any button is not pressed during 4 minutes and communication through the serial line is absent, the menu is automatically terminated and the system returns to normal operation.



- Menu can be made protected by the password (parameter *Password*) - access to the menu is protected by the password.
- The menu is modified by current configuration of the system; some parameters are temporarily unavailable - inaccessible parameter.

Entry of parameters can be limited by the access permission (parameter *Access*), parameters are unavailable - temporarily unavailable parameters.

#### LED

- § ERR - errors signaling
- § OPEN, MENU
  - OPEN - active signal on the input OPEN
  - MENU - option in MENU LED
- § CLOSE, PAR
  - CLOSE - active signal on the input CLOSE
  - PAR - active signal on the input I1
- § I1, SEL
  - I1 - active signal on the input I1
  - SEL - option in MENU LED
- § I2 - active signal on the input I2
- § PWR - enabled power supply +5V

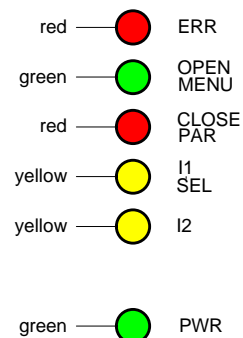

### 3.1. Used symbols for LED indication

Red	●	ERR	●	Light on
Green	●	MENU	②	Flashing (2 flashes)
Red	●	PAR	⊗	Light off
Yellow	●	SEL		

### 3.2. MENU LED - enter the MENU available without password

Press and hold MENU button.

Message MENU appears and LED ERR and MENU lights.

Release the button.

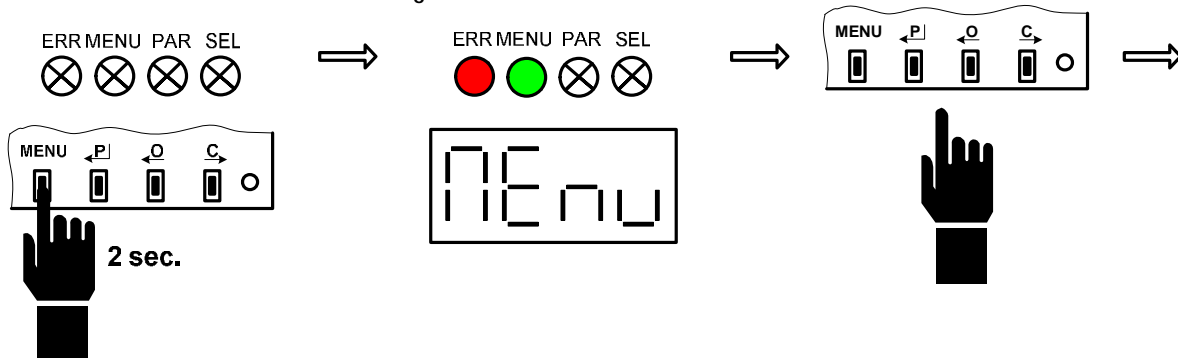

### 3.3. MENU LED - enter the MENU protected password

Press and hold MENU button.

Displayed writing BLOC. Currency is protects password is accesible only through PC or LCD.

Release the button.

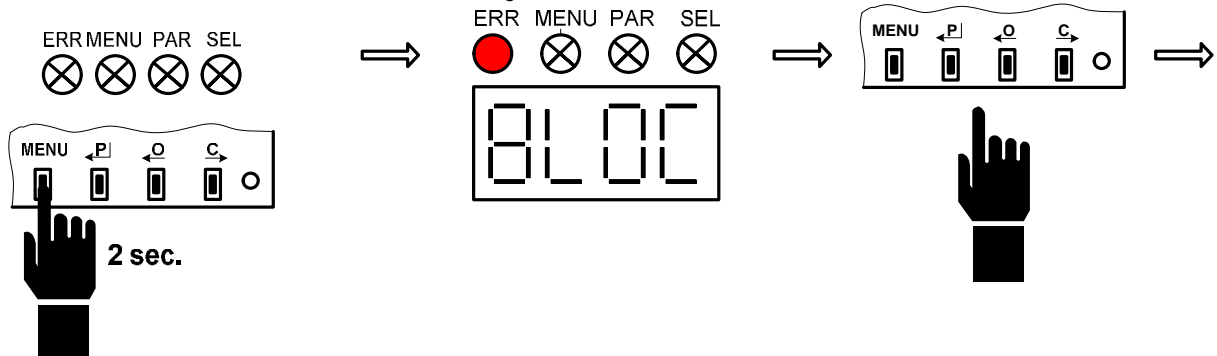

Message 1M appears. ERR LED lights and MENU LED blinks 1x.

ERR LED lights through presence in the MENU.

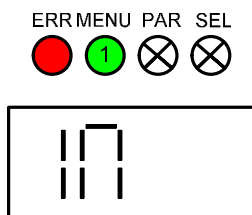

### 3.4. MENU LED - option MENU and parameters

Repeatedly press the button MENU in the short intervals

Green LED menu increases blinking or messages are displayed with another numbers

By the some menu Shortly press the button O or C and chosen parameter

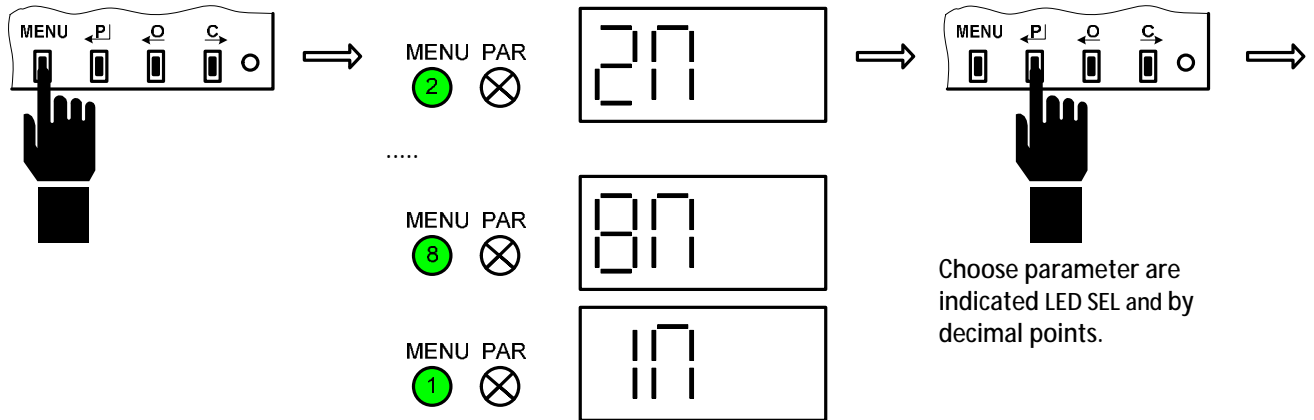

Parameter value is expressed by Red LED RAR - number of blinks or by message showed on display

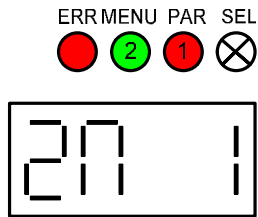

### 3.5. MENU LED - change and record of parameters

Repeatedly press the button P in the short intervals.

MENU LED MENU (green) blinks a menu number and LED PAR (red) blinks parameters value or message with parameter value is appeared.

Record a new value by pressing and holding P button.

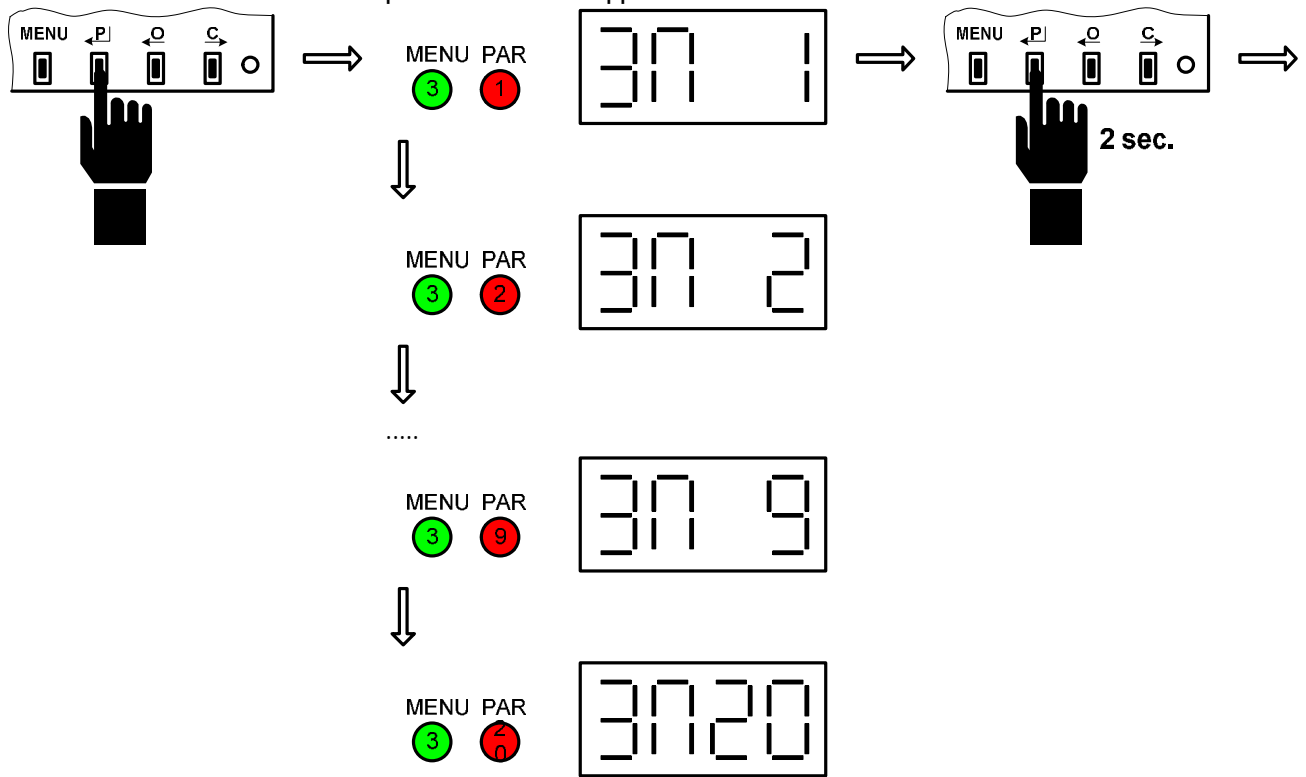

Hold the button until the PAR LEDs (red) or decimal points lighting.

Release the button.

Recorded value is displayed.

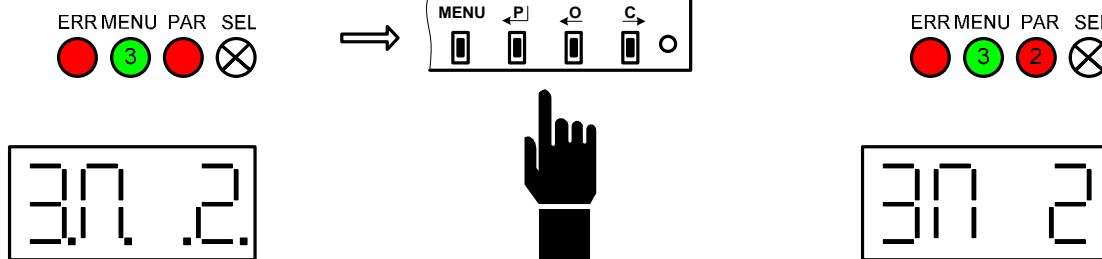

### 3.6. MENU LED – inaccessible parameter

§ Unless are in the menu on display displayed 2 dash, parameter it's no use for actual system configuration, is temporary inaccessible

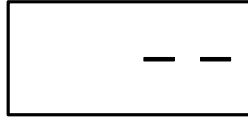

### 3.7. MENU LED – temporary inaccessible parameter

§ Unless are they by the record parameters in the menu on display displayed 2 dash, parameter is inaccessible to record

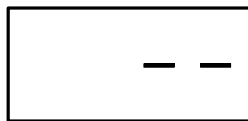

§ Accessing parameter is possible to change parameter access by program EHL Explorer with corresponding legitimate (HW key).

### 3.8. MENU LED - MENU exit

Press and hold MENU button.

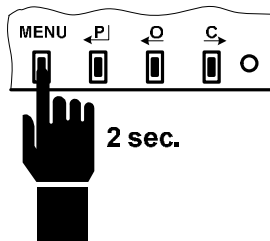

Record is confirmed by MENU LED (green) or following message.

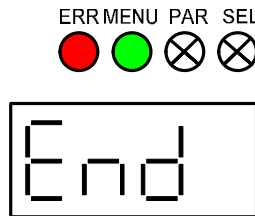

Release the button.

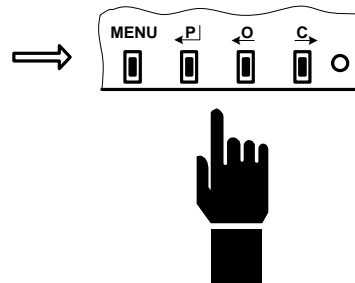



### 3.9. Particular parameters setup

#### 3.9.1. Limit position C setup

Setup a new position manually or by local control.

Record a new value by pressing and holding C button.

Hold the button until the MENU and PAR LEDs light or following message appeared.

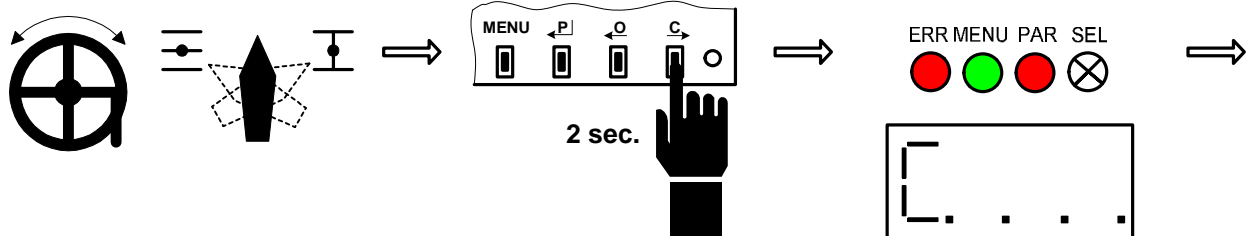

Release the button.

Position C is set up.

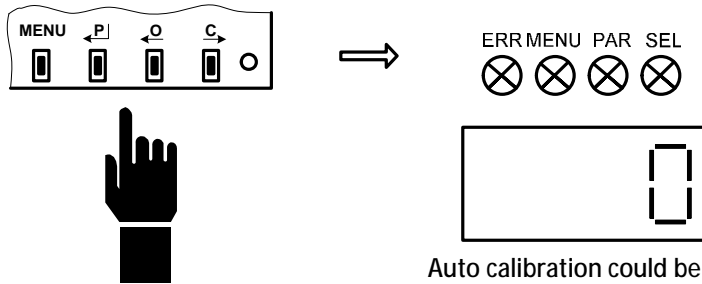

Auto calibration could be required - error 17

#### 3.9.2. Limit position "O" setup

Setup a new position manually or by local control.

Record a new value by pressing and holding O button.

Hold the button until the MENU and PAR LEDs light or following message appeared.

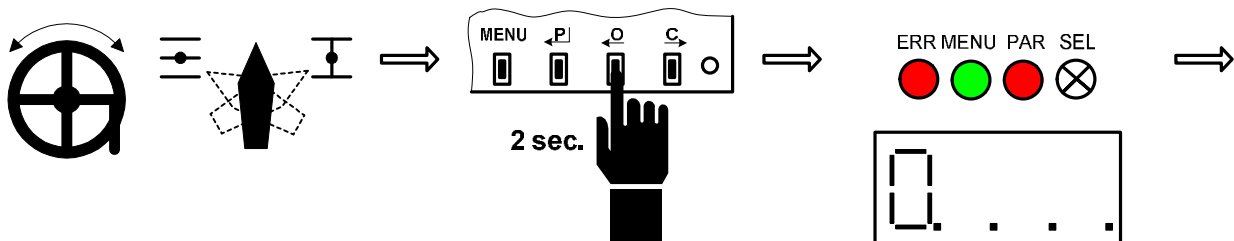

Release the button.

Position O is set up.  
Calibration could be required - error 17

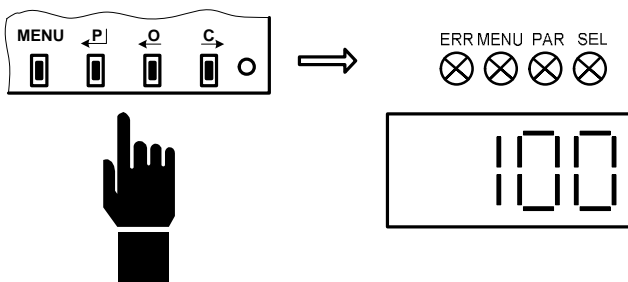



### 3.10. Regulator calibration

§ During calibration regulator arrive to near turning actuator at two directions.  
 § Be needed provide conditions for free turning actuator.

Press and hold P button.

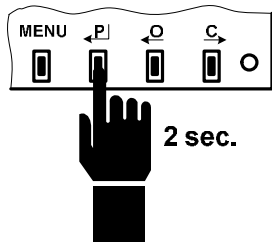

Hold the button until the LED ERR, LED MENU, LED PAR or decimal points light.

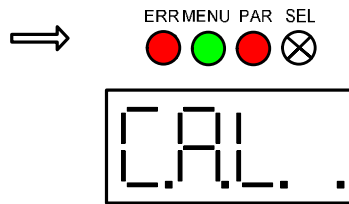

Release the button.

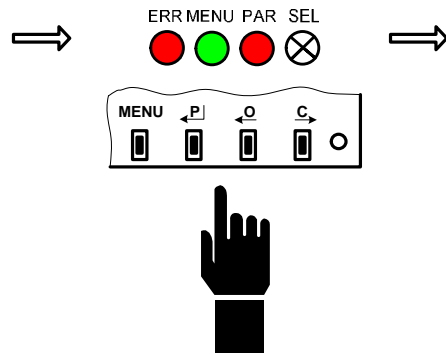

Wait!

The actuator is moving when the regulation is turned on.

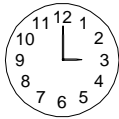

The successful calibration is confirmed by following message. Signalization 3 sec.

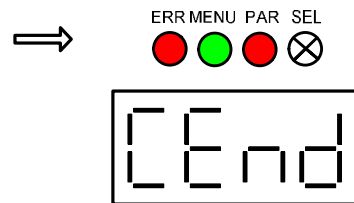

Position and errors display.

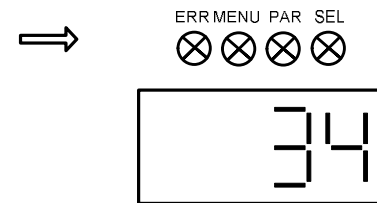

Faulty calibration is indicated by following message. Signalization 3 sec.

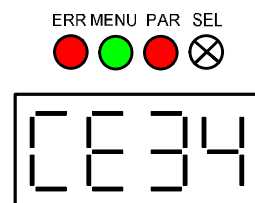

CE (calibration error)  
34=error number

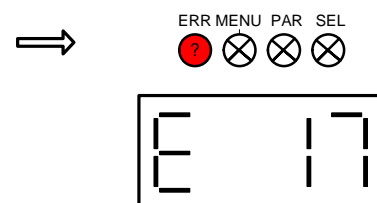

E17 = calibration error

!!! Notice: Explanation for each mistake is mentioned in caption Register errors.

### 3.11. MENU

#### 3.11.1. MENU 1 – Torque

##### 3.11.1.1. MENU 1 – Torque C

Display shows MENU 1.

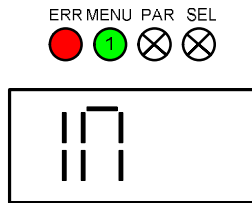

Select Torque "C" by pressing C button.

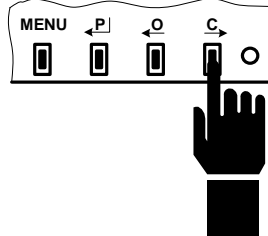

Min. Value of the torque "C" is displayed.

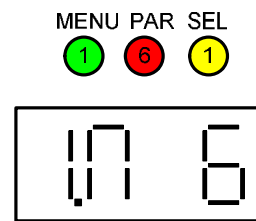

5= 50%  
6= 60%  
7= 70%  
8= 80%  
9= 90%  
10= 100%  
(Selection 50 and 60 % depend on min. Torque parameter.)

Change the Torque value by pressing P button.

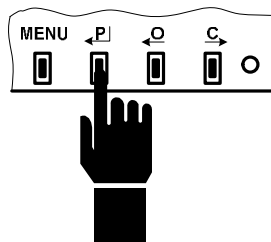

New value is displayed.

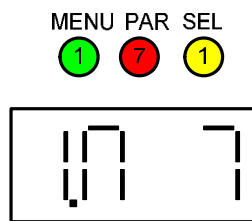

Record a new value by pressing and holding P button.

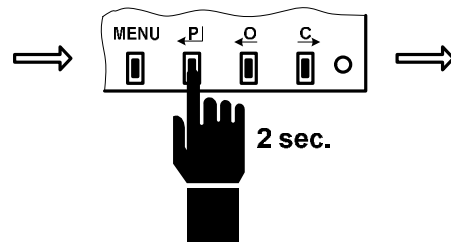

Record is confirmed by PAR LED (red) or decimal points lighting.

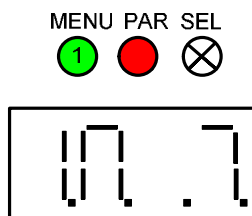

Release the button.

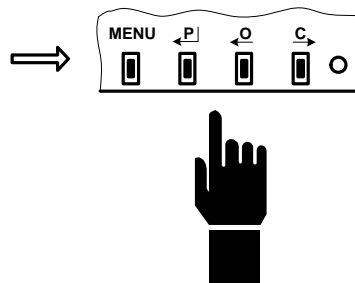

Recorded value is displayed.

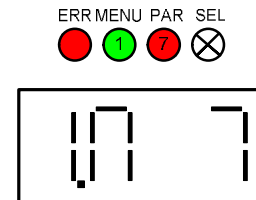

### 3.11.1.2. MENU 1 – Torque 0

Display shows MENU 1.

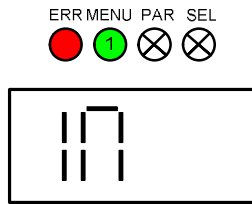

Select Torque "0" by pressing O button.

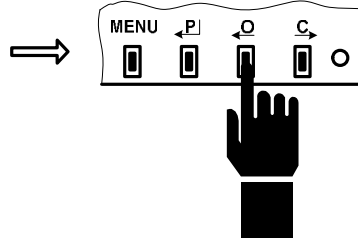

Min. value of the Torque "0" is displayed.

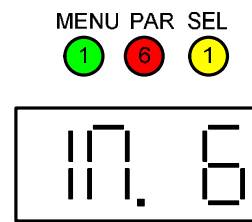

5= 50%  
 6= 60%  
 7= 70%  
 8= 80%  
 9= 90%  
 10= 100%  
 (Selection 50 and 60 % depend on min. Torque parameter.)

Change the Torque value by pressing P button.

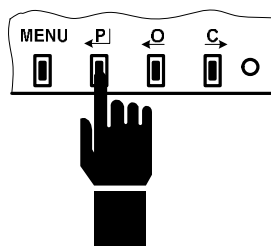

New value is displayed.

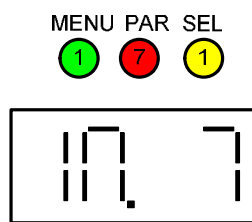

Record a new value by pressing and holding P button.

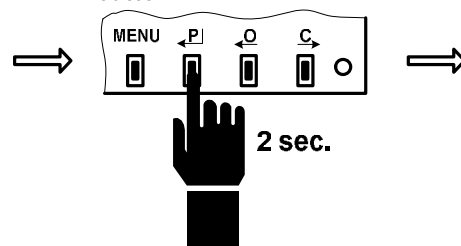

Record is confirmed by PAR LED (red) or decimal points lighting.

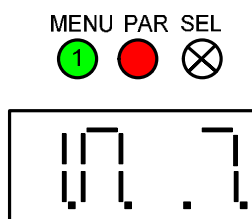

Release the button.

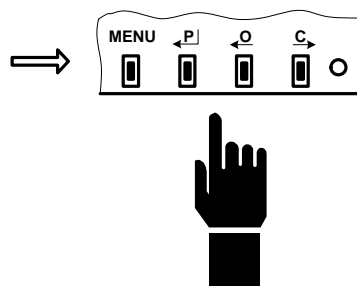

Recorded value is displayed.

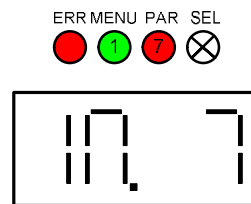

### 3.11.2. MENU 2 – End position

Display shows MENU 2.

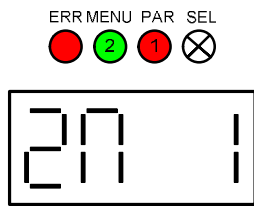

- 1= Torque O + Torque C
- 2= Torque C + Position O
- 3= Position C + Torque O
- 4= Position O + Position C

Change Shut-off value by pressing P button.

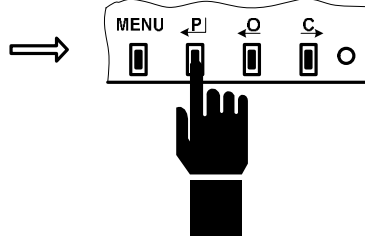

New value is displayed.

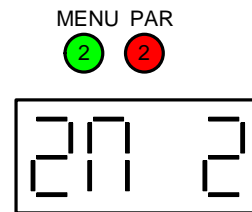

Record a new value by pressing and holding P button.

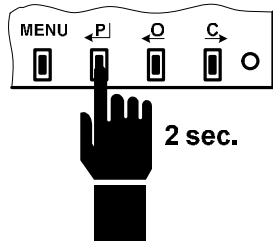

Record is confirmed by PAR LED (red) or decimal points lighting.

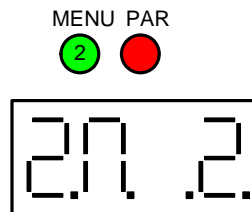

Release the button.

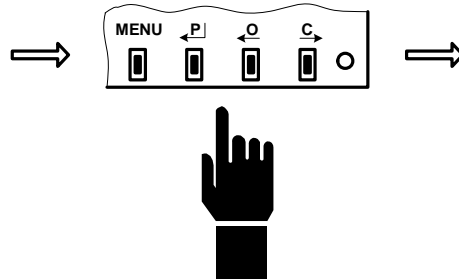

Recorded value is displayed.

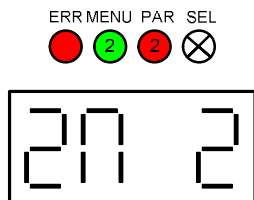

### 3.11.3. MENU 3 – Torque blockage

#### 3.11.3.1. MENU 3 – Time setup for torque blockage

Display shows MENU 3.

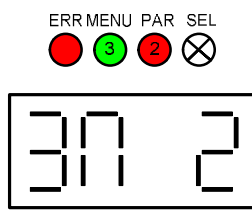

Time 0...20s  
 3= time 3s; max = 20s  
 0 = blocking shut off

Change time of blockage by pressing P button.

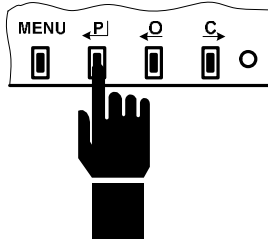

New value is displayed.

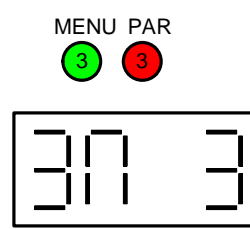

Record a new value by pressing and holding P button.

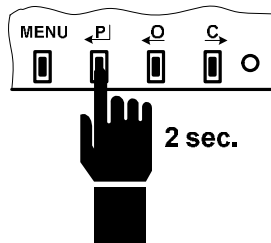

Record is confirmed by PAR LED (red) or decimal points lighting.

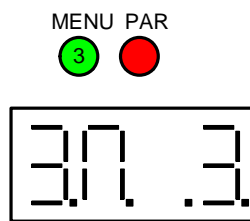

Release the button.

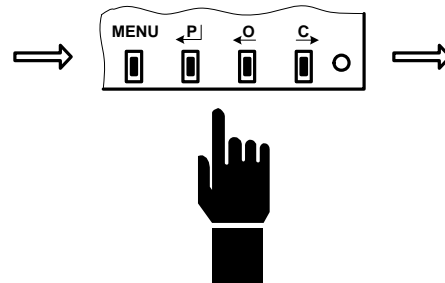

Recorded value is displayed.

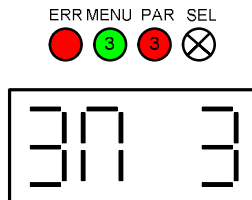

**3.11.3.2. MENU 3 – Setup position for torque O blockage**

Display shows MENU 3.

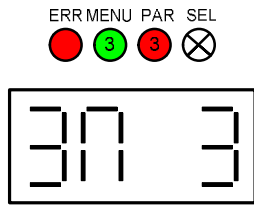

Setup a new position manually or by local control.

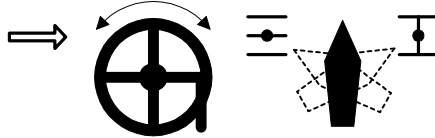

Record a new value by pressing and holding O button.

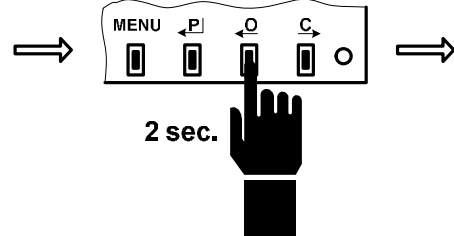

Record is confirmed by PAR LED (red) or decimal points lighting.

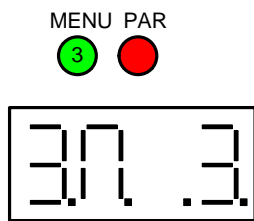

Release the button.

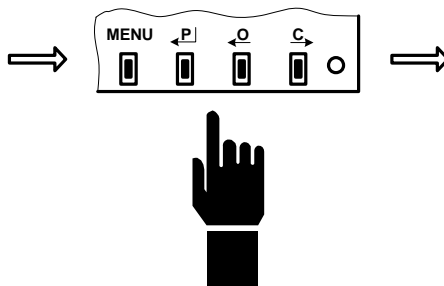

Recorded value is displayed.

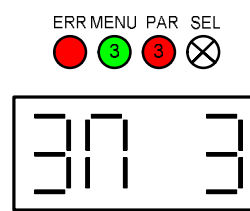

**3.11.3.3. MENU 3 – Setup position for torque C blockage**

Display shows MENU 3.

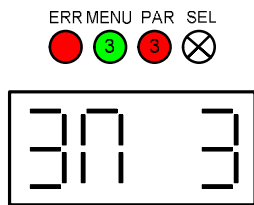

Setup a new position manually or by local control.

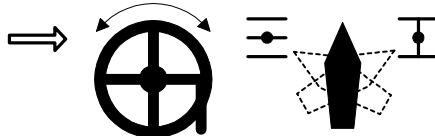

Record a new position by pressing and holding C button.

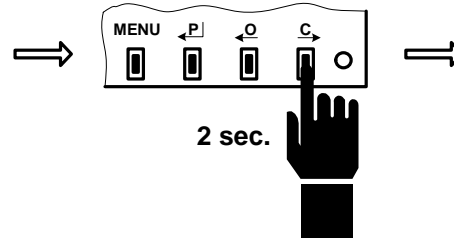

Record is confirmed by PAR LED (red) or decimal points lighting.

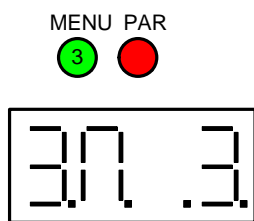

Release the button.

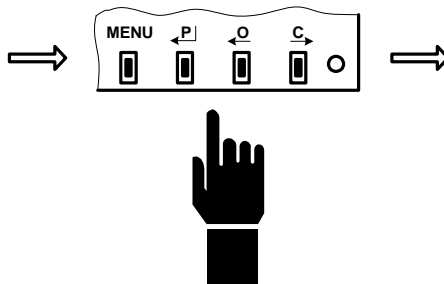

Recorded value is displayed.

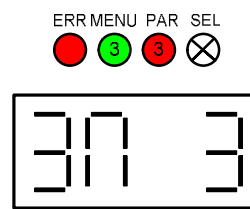

### 3.11.4. MENU 4 – Relay READY

Display shows MENU 4.

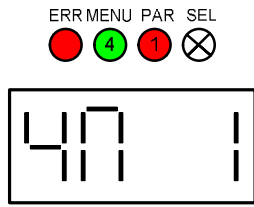

- 1= Errors
- 2= Errors or warning
- 3= Errors or not remote
- 4= Errors or warning or not remote

Change Relay READY function by pressing P button.

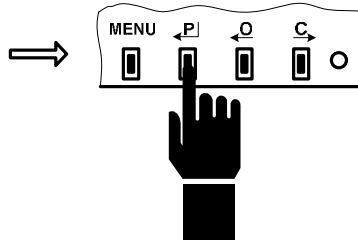

New value is displayed.

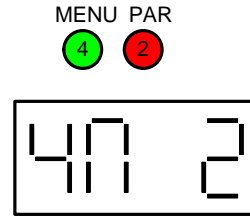

Record a new value by pressing and holding P button.

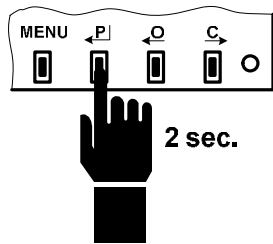

Record is confirmed by PAR LED or decimal points lighting.

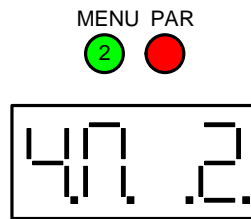

Release the button.

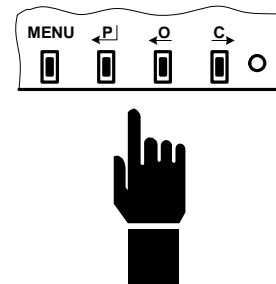

Recorded value is displayed.

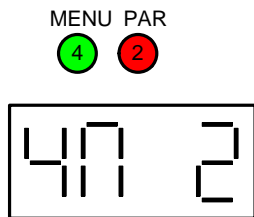



### 3.11.5. MENU 5 – Relay 1 .. 5

#### 3.11.5.1. MENU 5 – Relay 1..5

Display shows MENU 5.

Select Relay 1 by pressing C button.

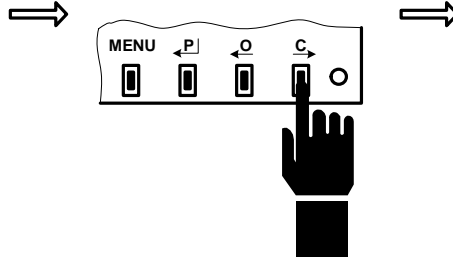
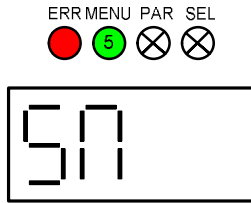

A decimal point indicates relay being set. Counted from left. When no decimal points light, than relay 5 will be set.

Relay 1 example.

Change Relay 1..5 function by pressing P button.

Relay 1

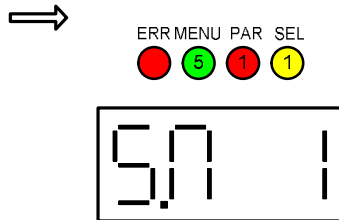
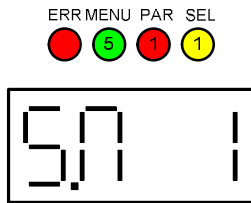

Relay 2

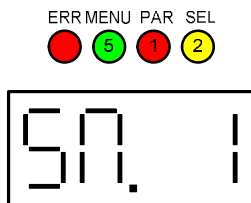

Relay 5

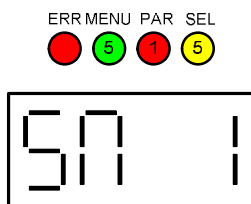

- 1= OFF
- 2= Position O
- 3= Position C
- 4= Torque O
- 5= Torque C
- 6= Torque O or Torque C
- 7= Torque O or Position O
- 8= Torque C or Position C
- 9= Open
- 10= Close
- 11= Move
- 12= Move - blink
- 13= To position
- 14= From position
- 15= Warning
- 16= Control – remote
- 17= Control – local
- 18= Control – off

New value is displayed. (example relay 1)

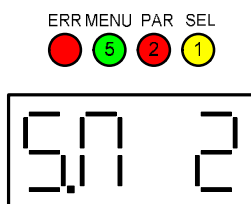

Record a new value by pressing and holding P button.

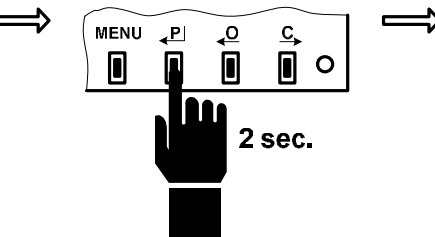

Record is confirmed by PAR LED or decimal points lighting.

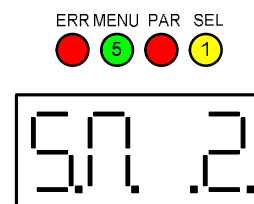

**3.11.5.2. MENU 5 – Position Relay 1..5**

Relay 1 .. 5 position could be set only when the appropriate relay function is equal to *To position* (13) or *From position* (14).

Setup a new position manually or by local control.

Record a new position by pressing and holding C or O button.

Record is confirmed by PAR LED (red) or decimal points lighting. (Example Relay 1)

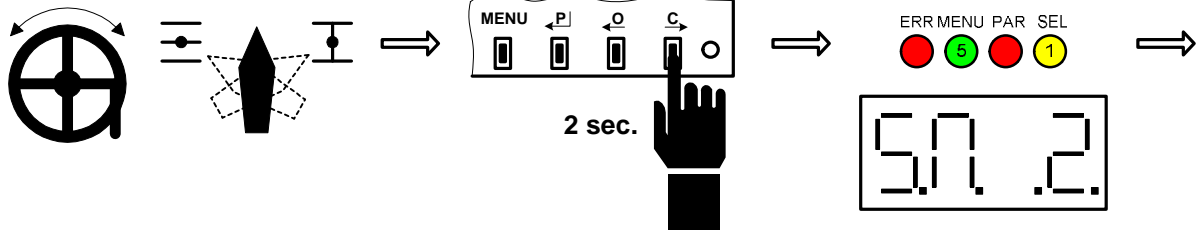

Release the button.

Recorded value is displayed. (Example relay 1)

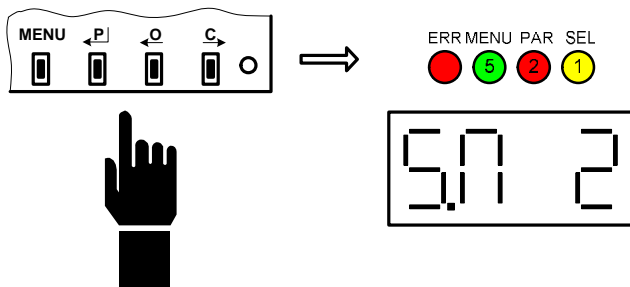

### 3.11.6. MENU 6 – CPT

Display shows MENU 6.

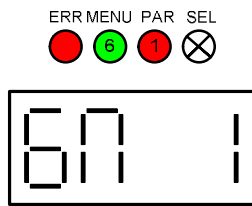

1= 4-20mA  
2= 20-4mA

Change CPT settings by pressing P button.

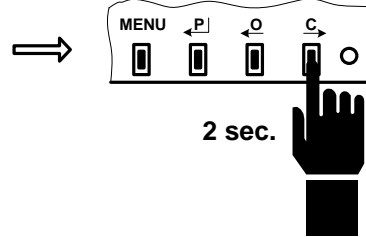

New value is displayed.

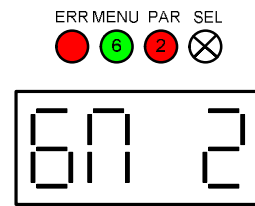

Record a new value by pressing and holding P button.

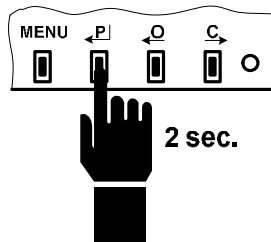

Record is confirmed by PAR LED (red) or decimal points lighting.

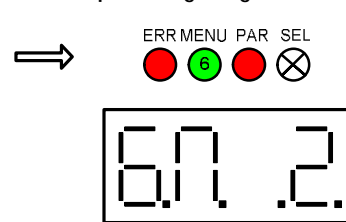

Release the button.

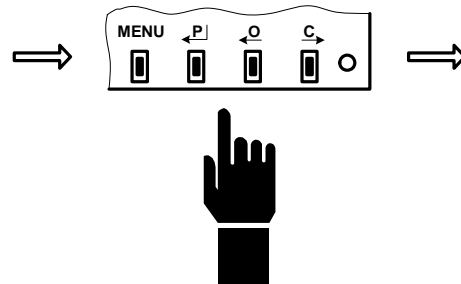

Recorded value is displayed.

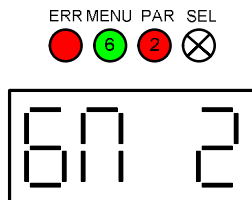

### 3.11.7. MENU 7 - Regulation, Analog control signal

#### 3.11.7.1. MENU 7 - Regulation

Display shows MENU 7.

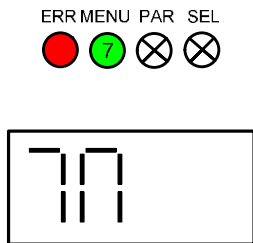

By pressing C button choose settings of regulation.

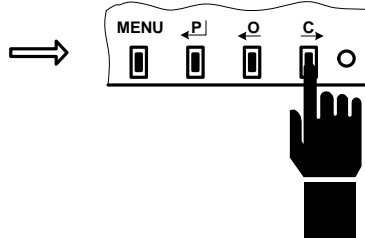

Value is displayed.

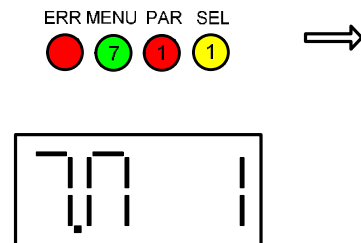

Change type of regulation by pressing P button.

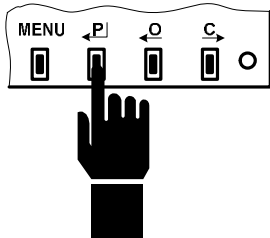

New value is displayed.

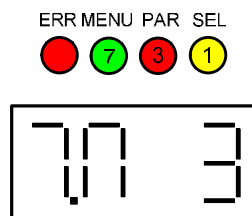

Record a new value by pressing and holding P button.

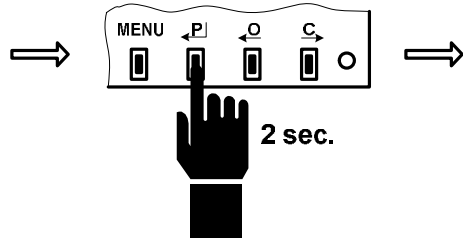

- 1= 2P
- 2= 3P
- 3= 3P/2P I2

Record is confirmed by PAR LED or decimal points lighting.

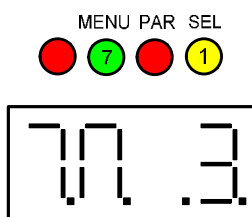

Release the button.

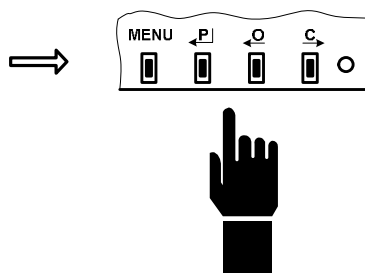

Recorded value is displayed.

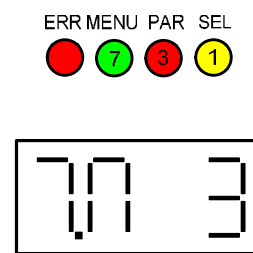

### 3.11.7.2. MENU 7 – Analog control signal

Display shows MENU 7.

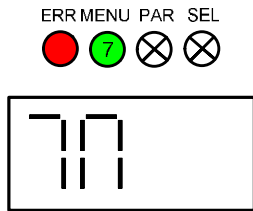

By pressing O button choose settings of parameter *Analog control signal.*

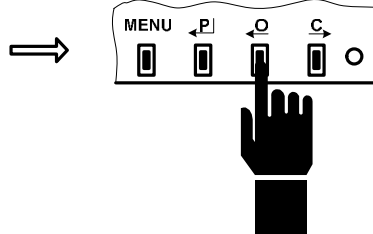

Value is displayed.

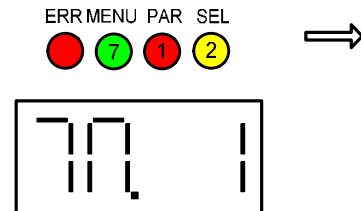

Change range of analog control signal by pressing P button.

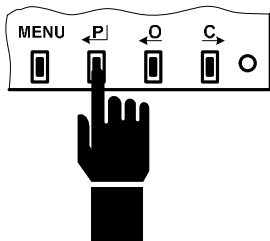

New value is displayed.

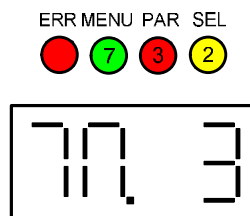

Record a new value by pressing and holding P button

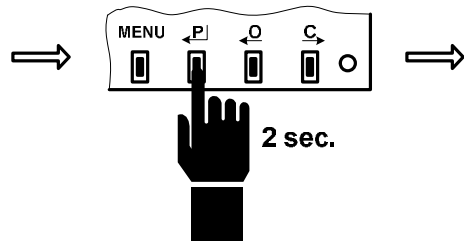

- 1= 4 - 20 mA (2-10 V)
- 2= 20 - 4 mA (10-2 V)
- 3= 0 -20 mA (0-10 V)
- 4= 20 - 0 mA (10-0 V)
- 5= 4 .. 12 mA
- 6= 12 .. 20 mA
- 7= 20 .. 12 mA
- 8= 12 .. 4 mA

Record is confirmed by PAR LED or decimal points lighting.

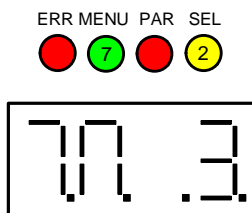

Release the button.

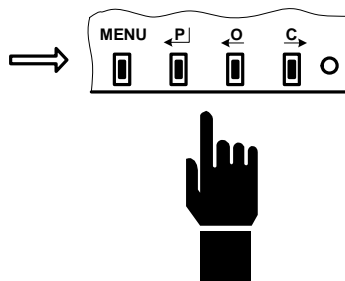

Recorded value *Analog control signal* is displayed.

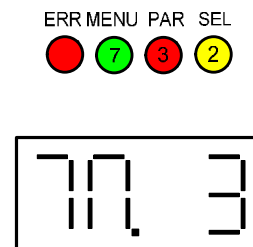

### 3.11.8. MENU 8 – Dead zone

Display shows MENU 8.

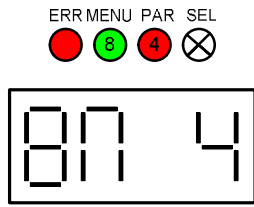

1-10= 1-10%

Change value of *Dead zone* by pressing P button.

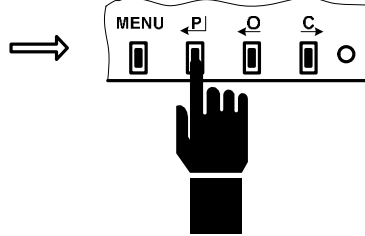

New value is displayed.

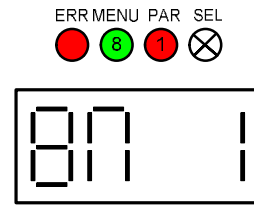

Record a new value by pressing and holding P button.

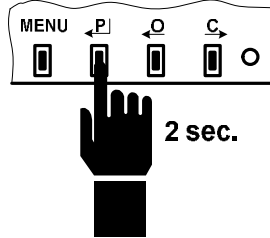

Record is confirmed by PAR LED (red) or decimal points lighting.

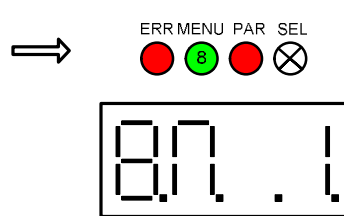

Release the button.

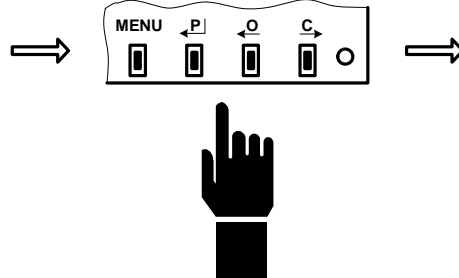

Recorded value is displayed.

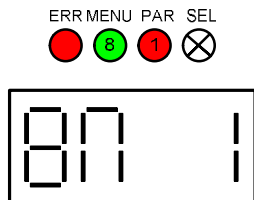

**3.11.9. MENU 9 – Failure**

**3.11.9.1. MENU 9 - Failure reaction**

Display shows MENU 9.

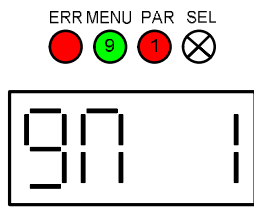

- 1= Open
- 2= Close
- 3= Stop
- 4= On position

Change reaction settings by pressing P button.

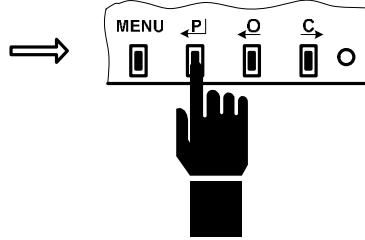

New value is displayed.

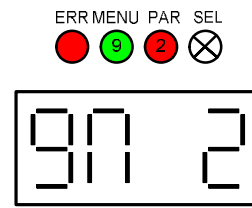

Record a new value by pressing and holding P button.

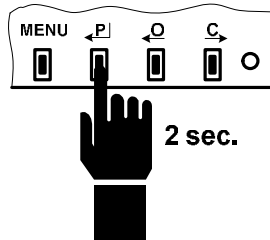

Record is confirmed by PAR LED (red) or decimal points lighting.

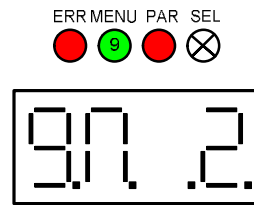

Release the button.

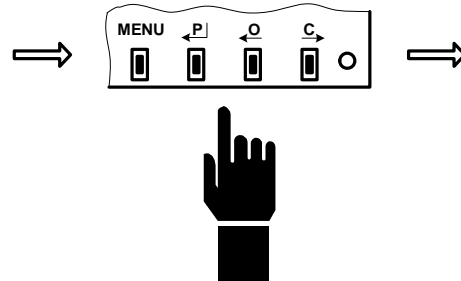

Recorded value is displayed.

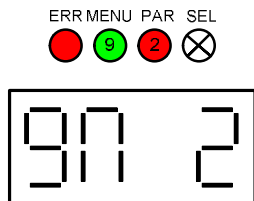

**3.11.9.2. MENU 9 – Safe position**

Setup *Safe position* is possible to only then, when is parameter *Failure reaction=Safe position*

Setup a new position manually or by local control.

Record a new position by pressing and holding O or C button.

Record is confirmed by PAR LED (red) or decimal points lighting.

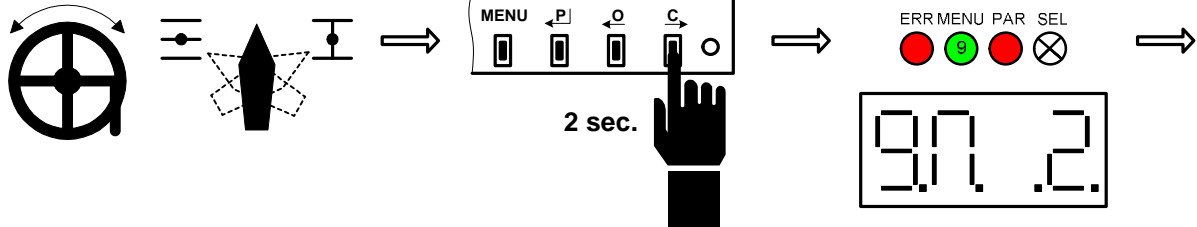

Release the button.

Recorded value is displayed  
*Failure reaction*

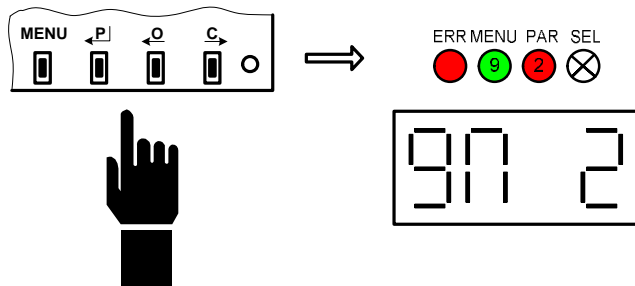



## 4. Register errors and warnings

Code	Name	Warning <sup>1</sup>	Error <sup>1</sup>	Reason	Reparation
1	ESD	X		Input ESD activated	<ol style="list-style-type: none"> <li>1. Deactivate input ESD.</li> <li>2. Check the wiring.</li> </ol>
2	Analog control signal	X		Analog control signal is < 3,5 mA	<ol style="list-style-type: none"> <li>1. Connect the control signal correctly to the connector +IN -IN</li> <li>2. Check the regulation parameter. If the analog control signal is disabled regulation parameter must be set to the 2P mode.</li> <li>3. Check the control signal using some multimeter.</li> <li>4. Check the parameter <i>analog control signal</i>. If the signal is 0 – 20mA then parameter must be set respectively.</li> <li>5. Recalibrate input of control signal. It means parameter 1mA and 20mA.</li> </ol>
3	Calibration	-	-	Calibration starts when torque is activated	<ol style="list-style-type: none"> <li>1. Move the actuator to the position when torque is not activated.</li> </ol>
4	Torque	X	X	Torque was activated outside the end positions	<ol style="list-style-type: none"> <li>1. Check the end limit position <i>O</i> and <i>C</i>. End limit position must be set between torque values.</li> <li>2. Check if there is some mechanical obstacle.</li> </ol>
6	Thermo fuse		X	Overheating is activated	<ol style="list-style-type: none"> <li>1. Wait until motor is cooled down.</li> <li>2. Check the wiring.</li> </ol>
7	Direction		X	Sense of rotation is reversed	<ol style="list-style-type: none"> <li>1. Check the sense of rotation of position sensor.</li> <li>2. Check the right wiring of the motor.</li> <li>3. Check the right connection of phases when three-phase motor is used.</li> </ol>
8	EEPROM	X		CRC of EEPROM does not match	<ol style="list-style-type: none"> <li>1. Record any parameter without changing its value.</li> </ol>
9	RAM		X	CRC of RAM does not match	<ol style="list-style-type: none"> <li>1. Reloading parameters will automatically repair this error.</li> <li>2. If the error occurred repetitively send the control unit to manufacturer.</li> </ol>
11	Menu mode	X		System is in menu	<ol style="list-style-type: none"> <li>1. Exit the LCD or LED MENU.</li> <li>2. Exit the setting mode in EHL explorer, e.g. after manual control of motor.</li> <li>3. Turn off and on the power line.</li> </ol>
12	Torque sensor		X	Error of torque sensor	<ol style="list-style-type: none"> <li>1. Change the broken gearbox of the torque sensor. Magnet must be in specified distance from the sensor and must have specified strength of magnetic field.</li> <li>2. Replace the broken torque sensor.</li> </ol>
13	Sensor of position 1		X	Error of position sensor 1	<ol style="list-style-type: none"> <li>1. Check the mounting of position sensor.</li> <li>2. Replace the position sensor module.</li> <li>3. Replace the gearbox of position sensor module.</li> </ol>
14	Sensor of position 2		X	Error of position sensor 2	See code nr.13
15	Sensor of position 3		X	Error of position sensor 3	See code nr.13
16	Sensor of position 4		X	Error of position sensor 4	See code nr.13
17	Regulator calibration	X		Unexecuted calibration	<ol style="list-style-type: none"> <li>1. Start regulator calibration.</li> </ol>
18	Torque calibration		X	Wrong settings of torque values	<ol style="list-style-type: none"> <li>1. Backup the parameters from system backup or from file.</li> <li>2. Torque calibration.</li> </ol>
19	Stroke		X	Wrong settings of stroke value	<ol style="list-style-type: none"> <li>1. Reset the parameters <i>Position C</i> and <i>Position O</i>. New values must meet the required range.</li> </ol>
21	Temperature <	X		Temperature is too low	<ol style="list-style-type: none"> <li>1. Check the parameter <i>Temperature min</i>.</li> <li>2. Check the value of current temperature.</li> <li>3. Check the function of heating.</li> </ol>
22	Temperature >	X		Temperature is too high	<ol style="list-style-type: none"> <li>1. Check the parameter <i>Temperature max</i>.</li> <li>2. Check the value of current temperature.</li> </ol>

Code	Name	Warning <sup>1</sup>	Error <sup>1</sup>	Reason	Reparation
26	Bus error		X	Bus error	<ol style="list-style-type: none"> <li>1. Check the wiring between all modules.</li> <li>2. Disconnect the bus cable from control unit. If the error is still active replace the control unit.</li> <li>3. Connect only the bus cable and disconnect from it all modules. If the error occurred, replace the bus cable.</li> <li>4. Consecutively connect particular modules. After each one check if the error occurred.</li> </ol>
28	Phase		X	Missing phase or wrong sequence of phases	<ol style="list-style-type: none"> <li>1. Check the voltage of each phase and also the voltage between all phases.</li> <li>2. Switch any two phases.</li> </ol>
29	Relay	X		Operating life of relay overflow	<ol style="list-style-type: none"> <li>1. Replace the relay and clear the counter <i>Sum engine O contacts</i> and <i>Sum engine C contacts</i>.</li> </ol>
31	ROM		X	Wrong CRC of ROM	<ol style="list-style-type: none"> <li>1. Turn off and on the power line. If the error appears again send the control unit to the manufacturer.</li> </ol>
33	Wrong command		X	Inputs O and C are active simultaneously.	<ol style="list-style-type: none"> <li>1. Check the function of superior system.</li> </ol>
34	Inertia	-	-	Calibration measured the inertia of actuator wrongly	<ol style="list-style-type: none"> <li>1. Start calibration.</li> </ol>
35	Stop time	-	-	Calibration measured the drifting wrongly	<ol style="list-style-type: none"> <li>1. Start calibration</li> </ol>
36	Manual control		X	Input SW3 for manual control is activated.	<ol style="list-style-type: none"> <li>1. Deactivation of input SW3 for manual control.</li> <li>2. Check the parameter <i>Manual control</i>. If the manual control is not active the value of parameter must be OFF.</li> </ol>
37	Position module		X	Error of communication of position module	<ol style="list-style-type: none"> <li>1. Check the wiring between module and control unit</li> </ol>
38	Torque module		X	Error of communication of torque module	<ol style="list-style-type: none"> <li>1. Check the wiring between module and control unit</li> <li>2. Check the parameter of torque configuration. When the module torque is enabled then the parameter must be set to the <i>switch-off min -100%</i> or <i>switch-off 100%</i>.</li> </ol>
39	Module LED		X	Error of communication of LED module	<ol style="list-style-type: none"> <li>1. Check the wiring between module and control unit</li> <li>2. Check the parameter <i>LED module</i>. When the module is used the value of parameter must be set to the X.</li> </ol>
41	Wrong position		X	Position of an actuator is out of set stroke	<ol style="list-style-type: none"> <li>1. Using hand control set the position back into operation range.</li> <li>2. Check the parameter <i>Position O</i> and <i>Position C</i>.</li> </ol>
42	Power Supply/Relay module		X	Error of communication of Power Supply/Relay module	<ol style="list-style-type: none"> <li>1. Check the wiring between module and control unit</li> <li>2. Check the parameter <i>Power Supply/Relay module</i>. When the module is used the value of parameter must be set to the X.</li> </ol>
43	Parameters		X	Different or out of bounds parameters in EEPROM	<ol style="list-style-type: none"> <li>1. Only using EHL explorer app. Parameters which are reported as wrong write the new value from allowed range.</li> </ol>
44	Rotation		X	Actuator is not rotating	<ol style="list-style-type: none"> <li>1. check if the motor is rotating. If not remove the cause.</li> <li>2. Check if the value <i>Position absolute</i> in window monitoring is changing. If the value is not changing during rotation then check the rotation of shaft with magnet of position sensor.</li> <li>3. Check the parameter <i>Rotation checking time</i>. Increase the value until it is ok.</li> </ol>
45	Reset	X		Processor was incorrectly reset	<ol style="list-style-type: none"> <li>1. This error is counted in counter of errors and it is automatically resolved. If the error is generated often then contact the manufacturer.</li> </ol>

Code	Name	Warning <sup>1</sup>	Error <sup>1</sup>	Reason	Reparation
46	Module LCD		X	Error of communication of LCD module	1. Check the wiring between module and control unit 2. Check the parameter <i>LCD module</i> . When the module is used the value of parameter must be set to the X.
47	Module type Position		X	Unknown type of position module.	1. Use different type of module. This one is not supported by control unit 2. Use the newer type of control unit
48	Module type Torque		X	Unknown type of torque module	
49	Module type LED		X	Unknown type of LED module	
51	Module type LCD		X	Unknown type of LCD module	
52	Module type Power Supply/Relay		X	Unknown type of PWR module	
54	I2C		X	Error of communication of I2C bus	1. Turn off and on the power line. 2. If the error is still active replace the control unit.
55	Power frequency		X	Indefinable Power frequency	1. To test parameters your timing network and parameter power supply board the system. As far as power supply board non - support frequency timing network, replace her in suitable type. 2. To test connection power supply in source power supply board, not allowed give out toward his disconnecting e.g . bad contact.
56	Voltage +5V	X		Voltage less as 4,5 V	1. Change power supply board 2. Change control unit
57	Torque check	X		Parameter <i>Torque check =unexecuted</i>	1. Perform functional <i>Torque check</i> and setup parameter <i>Torque check =Done</i>
58	End position	-	-	During calibration regulator has been achieved end position	1. Restart calibration regulator the best further from end positions

<sup>1</sup>Codes of errors may vary in different version of firmware or factory settings.  
If the errors persist then contact the manufacturer.

LED ERR – error indication



- § In case of EA error the error is indicated by the blink of LED ERR.
- § LED is flashed for a longer period, which indicates the beginning of the error.
- § The following number of blinks indicates:
  - o The errors of the units 1..9
  - o For the units 11..99 and after the short pause of the unit

Example: Fault 26, 8:

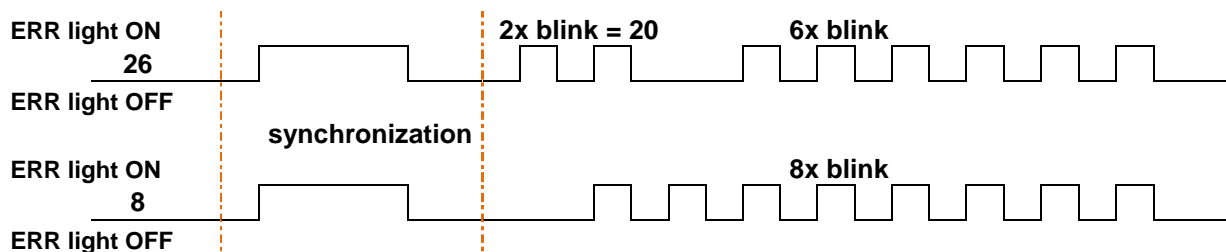

## 5. System DMS3 - Electronic control system for controlling the electric actuators (next EA) - the basic features and options

### Basic features:

- Modular, configurable system
- Control options:
  - 2-position / two-position
  - 3-position / three-position (linear, nonlinear)
  - current loop 0/4 – 20 mA
  - Switching between local and remote control
- Option of analog controller /in the one construction/with the standard equipment
- Easy setup with/using four buttons and six signalling LED or PC
- Backup option of the parameters set on the PC
- The possibility of drive/actuator diagnosing
- Absolute position sensing independent on standby/back-up power supply

### Technical parameters:

- Position sensing:
  - contactless magnetoresistive multi-turn: Discretion 1,87°, operating stroke to 1700 rev/rpm.
  - contactless magnetoresistive part-turn: Discretion 0,35°, operating stroke 60° up to 360°.
- Torque sensing:
  - contactless magnetoresistive, or switches
- Torque blocking:
  - 0-20 sec. at reversing at the end positions
- Input signal
  - Input I1, I2, OPEN, CLOSE:
 

Input voltage (on-state):	24 V DC, 15..30 V DC
Input voltage (off-state):	0..4 V DC
Input current:	app. 5 mA
Galvanic isolation:	optocomponents
Period of input sampling:	3 ms
Pulse length (on-state):	min. 50 ms
Pulse length (off-state):	min. 50 ms
  - Input -IN,+IN: 0/4 - 20 mA
 

Input resistance:	120 Ω
Input current:	0..20 mA
Maximum input current:	30 mA
Period of input sampling:	3 ms
Delayed response of controller:	50 ms
  - Local/remote control (option open, close, stop)
  - Temperature sensor of EA interior space,
- Output signal
  - 1 relay READY
 

Switching contact, release contact:	max. 24 VDC/2A; max. 230 V AC/0,25 A cos φ=1
-------------------------------------	--
  - 2...3 or 2...5 relay 250VAC 2A configurable acc. to customer's requirements
 

Switching contact:	max. 24 VDC/2A; max. 230 V AC/0,25 A cos φ=1
--------------------	--
  - Output -L, +L (passive CPT) 4 – 20 mA :
 

Loading resistance:	max. 500 Ω
Supply voltage:	18 V..30 V
Galvanic isolation:	optocomponents
Output +5V, GND:	
Output current:	max. 200 mA
  - LED display
  - LCD display (optional)
  - Dynamic brake (optional)
  - Thermometer heating of the interior space EA
  - Output DRO, DRC, DRHT:
 

Output type:	open collector
Output voltage:	max. 50 V
Output current:	max. 350 mA
- Voltage
  - 230V AC, 50Hz, 3W, overvoltage category II
  - 110-120V AC, 50Hz-60Hz
  - 24V AC, or 24VDC
  - 3x400V AC

Operating temperature: -40°C..+85°C

Systems scheme DMS3 – fig. 1

Terminal box of input and output of the control unit (ECU)

Name	Signal	Description		
OPEN	DMS3 SP (DMS3 SM4) <b>Position sensing unit</b>	Input for signal open	DMS3 Z1 / DMS3 Z2 <b>Power supply board</b>	
CLOSE		Input for signal close		
I1		Input I1		
I2		Input I2		
COM	Input	Inputs common pole - 2P control, I1, I2		
-IN	Switch torque O a Z	Input current loop		
+IN		Input current loop		
SH		Shielding of current output CPT		
-L		Negative pole of current output CPT	POWER	connector  inputs, outputs, relay
+L	Positive pole of current output CPT			
Type of terminal	DMS3 ST <b>Torque sensing unit</b>	READY, R1, R2 of ECU	DMS3 RJ Control unit	
Terminal Name				
NC	Output	READY, DLIN		
NO	Output	READY, DLIN		
R1	DMS3 L2 <b>LED display</b>	R1 NO		
R2		R2 NO		
COM		COM READY, R1		
Type of terminal		8 for the conductor 0,05 – 1,5 mm <sup>2</sup> cable/wire		
Terminal Name	DMS3 LCD <b>LCD display</b>	RE3, RE4, RE5 additional relay modules		
NC			COM	
COM		Relay 3		
NO	Output			
COM		Relay 4		
NO	<b>Local control module</b>			
COM		Relay 5		
NO	Output			
Type of terminal	DMS3 RE3 (DMS3 RE6) <b>Relay module</b>	8 for the conductor 0,05 – 1,5 mm <sup>2</sup> cable/wire	Serial line interface RS 232	
Terminal Name		Z1 or Z2		
Name		Description		
L	Input	Input phase wire		
N	Input	Input neutral wire		
PE	Input	Input equipment grounding wire		
Type of terminal box on ECU: RM 5,08 for the conductor 0,05 – 1,5 mm <sup>2</sup> cable/wire				

**SUPPLY BOARDS**

**DMS3 Z1**

Technical parameters:

Power supply 230VAC 50Hz 1,5VA / 115 VAC 50Hz 1,5VA / 24VAC 50Hz 2,6VA

**DMS3 Z2**

Technical parameters:

Power supply 230VAC 50Hz 2,3VA / 120 VAC 50Hz 2,3VA / 24VAC 50Hz 2,6VA

**DMS3 Z3**

Technical parameters:

Power supply 3x400VAC 50Hz 20 (32) VA

**Setup of parameters:**

- using buttons of control unit
- using buttons of local control
- using program EHL Explorer to PC

Setup of parameters using buttons control unit:

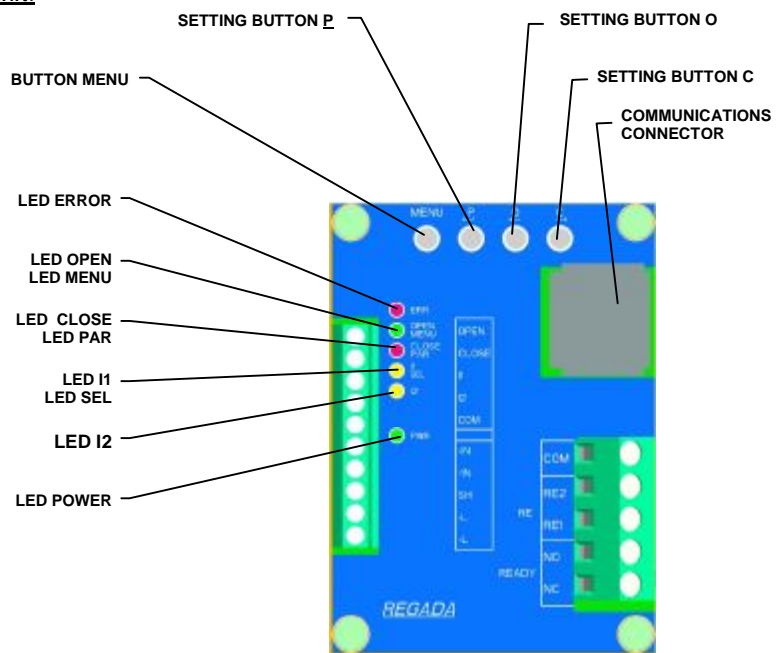

Control unit with setup buttons

Setup of parameters using buttons local control:

1. PADLOCK
2. BUTTON REMOTE - OFF - LOCAL
3. BUTTON OPEN /
4. BUTTON CLOSE /
5. BUTTON STOP / ESC
6. LCD DISPLAY
7. LED INDICATING RUN AND ERRORS

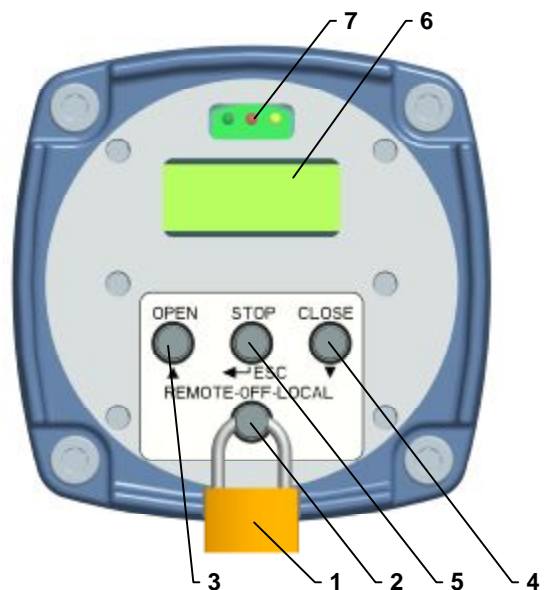

Local control with setup buttons

Setup of parameters using program EHL Explorer to PC:

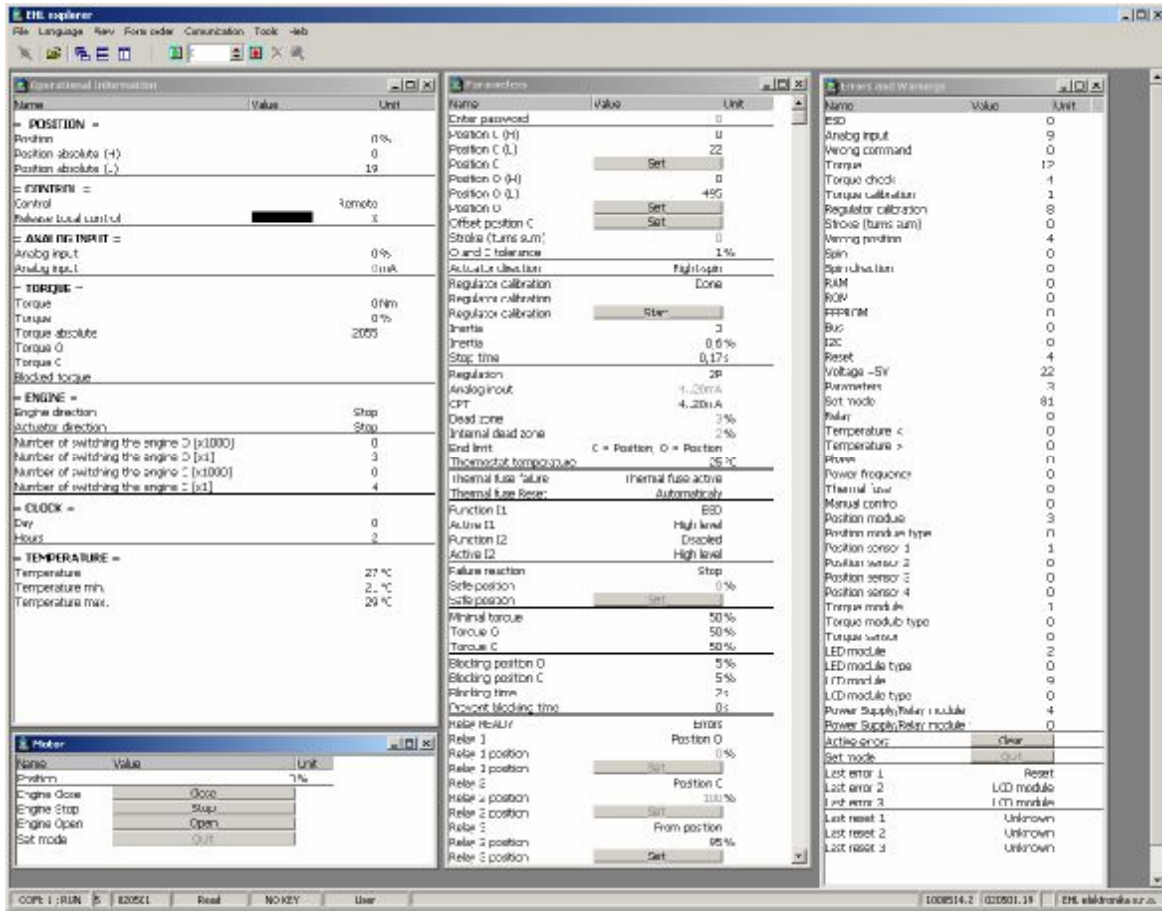

The program works in three modes:

- user mode designed for the average EA user , allows a more comfortable setting of parameters than by adjusting of local electronics control by buttons.
- service mode intended for trained service personnel. This mode is activated in case the hardware key is connected to the computer. In service mode it is possible to change all parameters of electronics in the window, annual statistics (number of errors, operating time, number of relay switching).
- production mode designed for trained workers of the manufacturing company. This mode is activated in case the hardware key for the production adjustment is connected to the computer. In the service mode it is possible to change all parameters of electronics in the box, annual statistics (number of errors, operating time, number of relay switching) and enter the actuator production data.

System options / Functions of system

Relay READY

Relay functions are dependent on the parameters Relay READY

The control unit includes Relay READY

Relay 1..2 or 1..5 (R1, R2, RE3, RE4, RE5)

Relay functions are dependent on the parameters Relay 1..5

The control unit includes Relay 1 a 2

Relay 3..5 can be on a separate relay board or source board

Options of relay 1-5

- § Inactive: Relay is permanently inactive;
- § PO; PZ; MO; MZ; MO or MZ; MO or PO; MZ or PZ; Opening; Closure; Move; Move – blink; Warning; Control – remote; Control – local; Control - off
- § To the position: Relay is activated from the position C (0%) up to the value of the parameter Relay position (2..5 for the other relays).

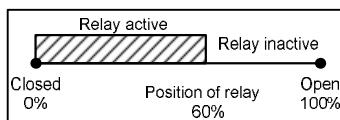

- § From the position: Relay is activated from the value of the parameter *Relay position* (2..5 for the other relays) to the position O (100%).

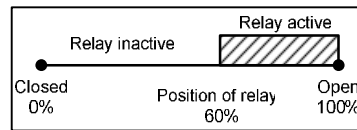

### Output HT (heating resistor)

ECU serves as temperature controller option, temperature is controlled acc. to the *Controller temperature* parameter  
Output controls heating of the internal space by the *heating resistance*.

### Position sensing

ECU must have attached position sensor with automatically identified type

### Torque sensing

ECU can operate in different modes of the torque measuring according to the setting of the parameter *Torque configuration*

- o Without sensing the torque
  - § EA without sensing the torque
  - § Switching off at the end positions can not be performed for the torques
- o Torques inputs
  - § Connection of the torque switches on the inputs of Torque O and Torque C of the position sensor
  - § Switches off at the active level on the inputs of Torque O and Torque C of the position sensor
- o Switch-off 100%
  - § Requires attached torque sensor
  - § Switch-off on the same 100% value of the torque
- o Switch-off min-100%
  - § Requires attached torque sensor
  - § Switch-off on the minimum.... 100% according to the parameters of Torque O and Torque C.
  - § The minimum is the value of the parameter Minimum torque

### Torque blocking

Torque blocking at the end positions

- § This option serves for the short-time switching off of the torques at the start-up of EA at the end positions for the separation from the tight closure.
- § The torque blocking can only occur at the end positions given by the parameters *Blocking position O* and *Blocking position C*.
- § At the extent 0..5% it is possible to block Torque O, at the extent 95..100% - Torque C.

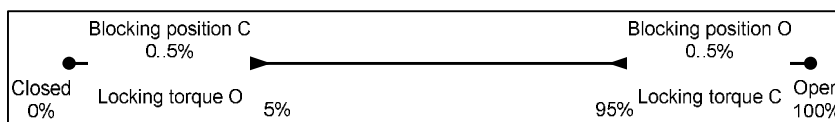

- § Torque blocking period is given by the parameter *Blocking period*, blocking is switched off by the setting of this parameter to 0.
- § Blocking period starts from the moment of the start-up and ends with the lapse of the period according to the parameter *Blocking period*.
- § In case of the evocation of the blocked torque in the area of the blocking of torques O or C, it is possible to evoke additional torque blocking up to the moment when EA is outside the area of torque O or C blocking.

### Torque blocking at start-up

- § This option serves for the short-time switching off of the torques at the start-up of EA, to overcome the large angular momentum.
- § Torque blocking can be evoked during the whole working range 0..100% in both directions.
- § Torque blocking period is given by the parameter *Start-up blocking period*, blocking is switched off by the setting of this parameter to 0.
- § Blocking period starts from the moment of the start-up of the drive and ends with the lapse of the period according to the parameter *Start-up blocking period*.
- § If during blocking shutdown of the drive occurs and the torque sensor detects the working torque, time keeping is stopped. At the drive spinning, the time counting continues.

### Switching off at the end positions

- § Switching off of EA at the end positions is defined by the parameter *End position*.
- § It is possible by the position O or Z or by the torques O or Z evoked at the end positions.

### Two-position controller (ON/OFF control)

- § Two-position controller works in two modes, and uses these inputs:
  - o permanent signal:



§ EA is opened or closed only at the duration of the signal in the inputs *OPEN, CLOSE* o pulse mode:

§ EA is opened or closed after bringing the pulse to the inputs *OPEN, CLOSE*

EA stops after bringing the pulse to the input *I1-STOP* (or, at the end positions).

Three-position regulator (Three-position control – modulating mode)

§ Three-position regulator uses input for analog control signal (terminals *-IN, +IN*).

§ Feeding current to the input will cause the transfer of the request for the position of EA, the control unit will evaluate the request and switch the drive in the desired direction.

Inertia

§ Inertia is defined by the moment of EA switching off.

§ ECU switches off the drive by the value of inertia before the required position.

§ Inertia value is measured at the process of the controller calibration (see Controller calibration) and the value is entered as a parameter *Inertia*.

Inner dead zone

§ Inner dead zone defines the moment of achievement of the desired position (end of regulation).

§ Inner dead zone is actually the tolerance zone of the required position that defines the control accuracy.

Dead zone

§ Dead zone defines the moment of the drive switching on.

§ If the difference between actual and desired position (control error) is greater than that given by the dead zone max. regulation deviation, then the drive is switched on in the requested direction.

Description of regulation measures

§ If the control signal (requested position) changes and the difference of the actual and requested position (control error) is greater than the value of dead zone (parameter *Dead zone*), the evocation of the regulation measures will occur during which the EA will try again to reach the requested position.

§ The actual position will approximate to the requested position and at the position of the inertia (parameter *Inertia*) lower than the requested position EA will be switched off. Then the end of the inertia is awaited (parameter *Stop time*).

§ If after the end of the inertia the actual position will be between the inner dead zone and dead zone, then the single-step mode is activated, when the small changes of the position are achieved by the short drive switching (parameter *Step*).

§ With these short steps the end of the actual position to the inner dead zone is reached (parameter *Inner inertia*). The end of the regulatory measures takes place in the inner dead zone will.

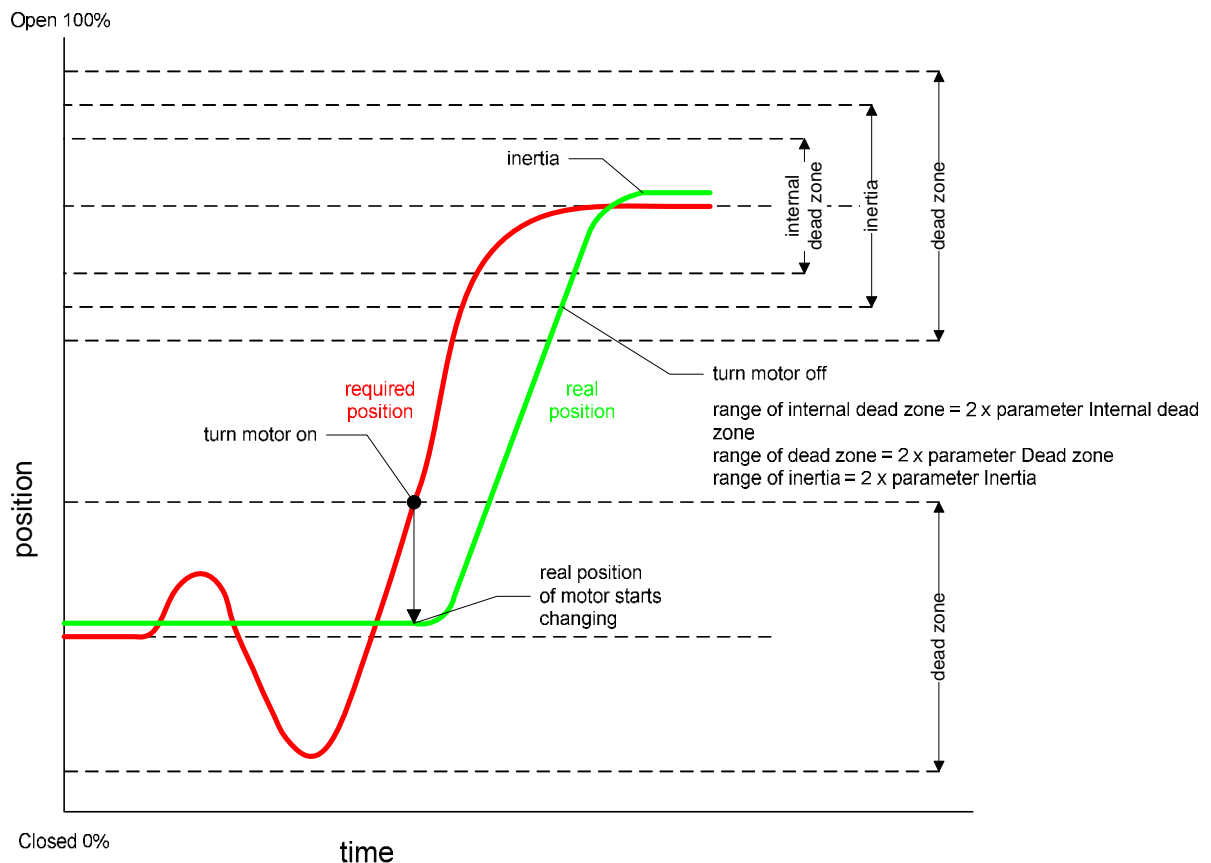

### Control of the end positions for the three-position controller.

- § The control mode is changed at the end positions so as to ensure tight closure and full opening.
- § If the switching off at the end position at the torque is not selected (parameter *End position*), then EA is switched off exactly at the position 0% and 100% without any control deviation.
- § If the tight close of opening is necessary and it is possible to evoke the torque, then it is possible to use the switch off with the torque at the end positions (parameter *End position*).
- § Close or opening to the position 0% or 100% or to the torque C or O is evoked every time when the value of the control signal is set to the area of the Tolerance O and C.

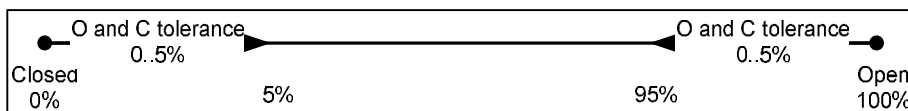

### Clock mode

- § Clock mode serves for the slowing of EA readjustment period.
- § It can be activated separately for the direction Open, Close or for both directions simultaneously (parameter *Cycle Mode*).
- § For both directions Open and Close can be set up separate zones for the clock mode (parameters *Cycle position O 1*, *Cycle position O 2* and *Cycle position C 1*, *Cycle position C 2*).
- § Drive running period and its pauses can be adjusted (parameter *Cycle running time* and *Cycle pause*).

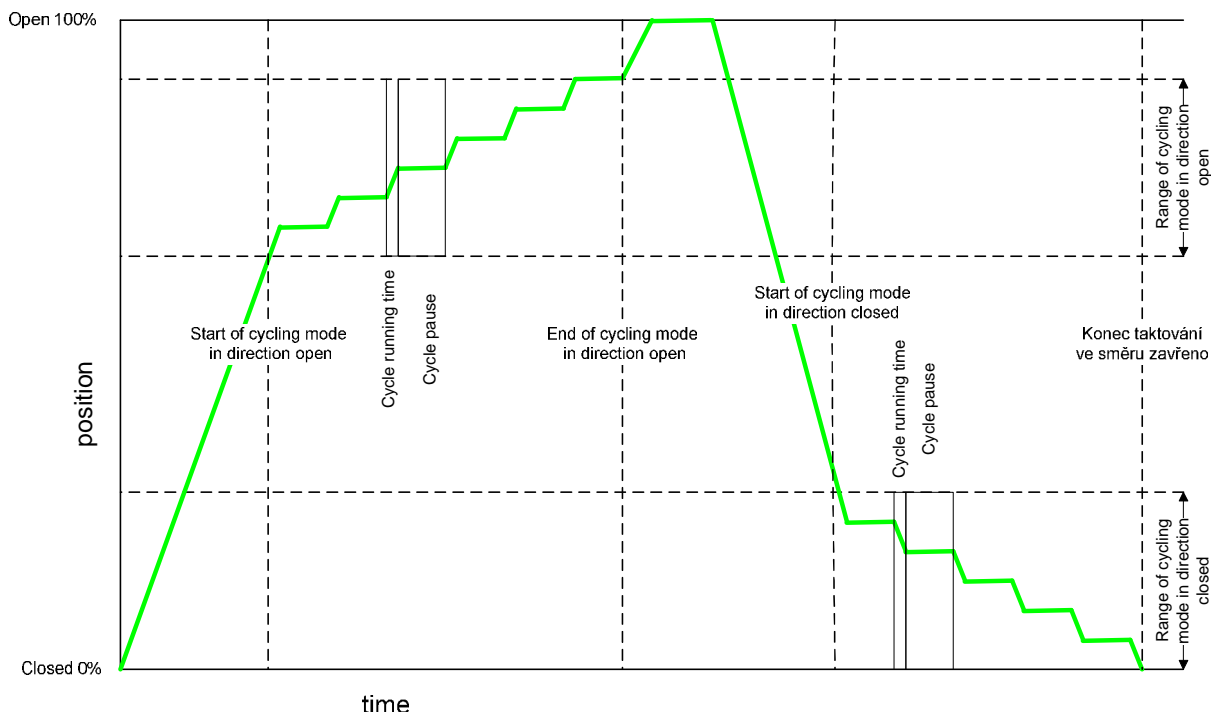

### Calibration of the controller

- § Calibration of the controller is a process at which the control unit measures EA inertia. Inertia is then saved as two parameters *Inertia* and *Stop time*.
- § Calibration of the controller can be started from MENU LED, MENU LCD or EHL Explorer.
- § Unperformed controller calibration is signaled as a warning see. Chapter List of errors and warnings.
- § It may be shown as an unstable control, when EA:
  - passes through the requested position - *Inertia* parameter is less than the actual inertia
  - stops before the requested position and steps for a long time - *Inertia* parameter is greater than the actual inertia.
- § If EA with performed calibration shows mentioned instable control regulation, then the inertia has apparently changed so much (eg pipes without medium and with medium) that it is necessary to perform a new controller calibration.
- § Parameter *Stop time* serves for two purposes:
  - During the control measures, viz. chapter Description of the regulatory measures.
  - As the pause at EA reversing when the drive stops before the switch of the opposite direction of revolution is secured by this period.

### Local control in MENU LED and LCD

- § If EA is equipped with a block of local control, local control can be used to change position at the setting of eg. end positions.
- § In the MENU LED and LCD, EA can be rotated by the local control by the end position O and C.

- § At the end positions of EA, the safety stop takes place. If it is necessary to continue the revolutions at the end positions, it is enough just to give command for the opening or closing with the button of the local control.

#### Torques control

- § For the security reasons ECU supplied by the manufacturer of EA have set parameter Torque check = Unexecuted.
- § This setting ensures that EA switched for the first time will switch off in any direction of revolutions for the both torques.
- § During the torques control it is necessary to verify whether at the change of the revolutions O the activation of the torque O and at the change of the revolutions C the activation of C torque occurs.

If the function of the torques is in order, the value of the parameter can be set to Torque check = Done, at this setting the torque O switches off the revolution in the direction O and the torques C in the direction C.

---

REGADA, s.r.o.  
Strojnícka 7  
080 01 Prešov  
Slovak Republic

Tel.: +421 (0)51 7480 460  
Fax: +421 (0)51 7732 096  
E-mail: [regada@regada.sk](mailto:regada@regada.sk)  
[www.regada.sk](http://www.regada.sk)