



## Štandardné vybavenie:

- Napájacie napätie 230 V AC
- Svorkovnicové pripojenie
- 2 momentové spínače
- 2 polohové spínače
- Mechanické koncové dorazy
- Mechanické pripojenie prírubové ISO 5211
- Miestny ukazovateľ polohy
- Ručné ovládanie
- Stupeň krytia IP 67

## Standard equipment:

- Voltage 230 V AC
- Terminal board connection
- 2 torque switches
- 2 position switches
- Mechanical stop ends
- Mechanical connection - flange ISO 5211
- Mechanical position indicator
- Manual control
- Protection code IP 67

## Špecifika ná tabu ka \Specification table\ SP 2.4

Objednávaci kód \Order code\ 284. x - x x x x x / x x

Typ klímy \Climate resistance\	Okolité teplota \Ambient temperature\	Korózna kategória <sup>10)</sup> \Corrosivity category\	Krytie \Enclosure\	↓
Mierna \Standard \	-25°C ... +55°C	C3	IP 67	<b>1</b>
	-25°C ... +55°C	C3	IP 68 <sup>11)</sup>	5
Tropická vlhká + OV \Tropics and Wet\	-25°C ... +55°C	C4	IP 67	2
Chladná \Cold \	-50°C ... +40°C	C3	IP 67	3
Tropická suchá a suchá \Tropical dry and Dry\	-25°C ... +55°C	C3	IP 67	6
Morská \Sea\	-50°C ... +40°C	C4	IP 67	7
Arktická \Arctic\	-60°C ... +40°C	C3	IP 67	8

Elektrické pripojenie \Electric connection\	Napájacie napätie \Voltage\	Schéma zapojenia \Wiring diagram\	↓
Na svorkovnicu \To terminal board\	230 V AC	Z1a + Z11a	<b>0</b>
	220 V AC		L
	3x400 V AC	Z78a + Z12a <sup>22)</sup>	<b>9</b>
	3x400 V AC <sup>28)</sup>		Z303 + Z12a <sup>22)</sup>
	3x380 V AC	Z78a + Z12a <sup>22)</sup>	M
	3x380 V AC <sup>28)</sup>		Z303 + Z12a <sup>22)</sup>
	24 V AC	Z507a	<b>3</b>
	24 V DC	Z503a	A
Na konektor <sup>21)</sup> \To connector\	230 V AC	Z1a + Z11a	5
	220 V AC		P
	3x400 V AC	Z78a + Z12a <sup>22)</sup>	7
	3x400 V AC <sup>28)</sup>		Z303 + Z12a <sup>22)</sup>
	3x380 V AC	Z78a + Z12a <sup>22)</sup>	R
	3x380 V AC <sup>28)</sup>		Z303 + Z12a <sup>22)</sup>
	24 V AC	Z507a	8
	24 V DC	Z503a	C

Vypínací moment \Switching-off torque\	Max. zaťažovací moment \Max. load torque\		Elektromotor \Electric motor\ 230 V, 220 V AC		Elektromotor \Electric motor\ 3x380, 3x400 V AC   24 V AC/DC			↓
	Režim prevádzky Otvor-Zatvor <sup>32)</sup> \ON - OFF duty\	Regulačná prevádzka <sup>33)</sup> \Modulating duty\	Doba prestavenia \Operating time\	[W]	Doba prestavenia \Operating time\ <sup>34)</sup>		[W]	
					AC	AC/DC		
575 Nm	500 Nm	400 Nm	40 s/90°	60	40 s/90°	90	65	<b>0</b>
			80 s/90°					<b>1</b>
			160 s/90°					20

Pracovný uhol \Operating angle\		↓
S pevnými dorazmi \With stop ends\	60°	A
	90°	<b>B</b>
	120°	C
	160°	D
Bez dorazov \Without stop ends\	60°	K
	90°	L
	120°	M
	160°	N
	360°	P
	> 0° 360° <sup>41)</sup>	Z

Pokračovanie na  
aľšej strane  
\Next page\

## Poznámky:

10) Kategória klimatickej odolnosti podľa ISO 9223 / EN ISO 12944-2.

11) IP 68 - 10 m / 48 hod.

21) Vyhotovenie s konektorom len do -40°C.

Schémy zapojenia sú uvedené bez číselného označenia na konektore. Úplná

## Notes:

10) Climate resistance according to ISO 9223 / EN ISO 12944-2.

11) IP 68 - 10 m / 48 hours.

21) The version with connector in -40°C only.

Wiring diagrams are not showing connector pin numbers. Complete diagram on

Objednávací kód \Order code\ 284. x - x x x x x x / x x

Vysiela polohy \Transmitter\		Zapojenie \Connection\	Výstup \Output\	Schéma zapojenia \Wiring diagram\	
Bez vysiela a \Without transmitter\		-	-	-	A
Odporový \Potentiometer\	Jednoduchý \Single\	-	1 x 100 1 x 2 000	Z5a	B F
	Dvojitý <sup>22)</sup> \Double\	-	2 x 100 2 x 2 000	Z6a	K P
Elektronický - prúdový \Electronic position transmitter\	Bez zdroja \Passive \	2-vodi \2-wire\	4 - 20 mA	Z10a	S
		3-vodi \3-wire\	0 - 20 mA	Z257a	T
			4 - 20 mA		V
	So zdrojom <sup>59)</sup> \Active \	2-vodi \2-wire\	0 - 5 mA	Z269a	Y
			4 - 20 mA		Q
		3-vodi \3-wire\	0 - 20 mA 4 - 20 mA 0 - 5 mA	Z260a	U W Z
Prúdový \CPT\	Bez zdroja \Passive \	2-vodi \2-wire\	4 - 20 mA	Z10a	I
	So zdrojom \Active \ <sup>59)</sup>			Z269a	J

Mechanické pripojenie \Mechanical connection\		Tvar pripoj. dielca \Coupling shape\		Rozmerový ná rt \Dimensional drawing\	
		ISO	Rozmer \Dimension\		
Príruba \Flange\ ISO 5211	F10/F12	D-27	27x27	P-1147 P-2148/F	A
		L-27			B
		H-27	27x48 <sup>62)</sup>		C
		V-50	Ø50 <sup>62)</sup>		D
		D-22	22x22		E
		L-22			F
		H-22	22x32 <sup>62)</sup>		G
		V-42	Ø42		H
		-	- <sup>65)</sup>		M
		H-16	16x22 <sup>62)</sup>		N
		H-19	19x28 <sup>62)</sup>		P
		V-20	Ø20		9
		V-30	Ø30		7
V-45.4	Ø45.4 <sup>63)</sup>	V			
Stojan, výstupný hriade , pero \Stand, Output shaft, Key\	-	Ø50	P-1395, P-1413/B P-2148/F	J	
Stojan + Páka \Stand + Lever\	-	-		K	
Stojan + Páka + ahadlo TV 50-1/25 \Stand + Lever + Pull-rod TV 50-1/25\	-	-		L	

Rozšírené vybavenie \Additional equipment\		Schémy zapojenia \Wiring diagrams\					
		230 V AC	3x400 V AC	24 V AC	24 V DC		
A	2 prídavné polohové spína e \2 additional position switches\ <sup>22)</sup>	Z11a	Z12a	Z507a	Z503a	0	0
E	Vyhrievací odpor s tepelným spína om \Space heater with thermal switch\	Z1a	Z78a	Z507a	Z503a	0	2
C	Miestne ovládanie (len do -40 °C) \Electric local controls (only till -40 °C)\	Z270i	Z90c, Z304a	Z509a	Z505a	0	7
D	Vyhrievací odpor \Space heater\	Z1a	Z78a	Z507a	Z503a	1	5
H	Pozlátané kontakty mikrosvína ov, detaily po konzultácii s výrobcom \Gold coated contacts of microswitches, details after consultation with producer\					4	0

Dovolené kombinácie a kódy \Allowed combination and code\:  
**A+E=04**, A+C=08, E+C=10, A+E+C=12, A+D=16, C+D=17, A+C+D=18

**Poznámky:**

- 22) Vyhotovenie 3x400 V (380 V) s prídavnými polohovými spína mi a dvojitým vysiela om po dohode s výrobcom.  
28) Vyhotovenie s reverza nými stýka mi.  
32) Týmto momentom je možné za ažova servopohon v režime S2-10 min, resp. S4-25%, 6-90 cyklov/hod.  
33) Týmto momentom je možné za ažova servopohon v režime S4-25%, 90-1 200 cyklov/hod.  
34) Odchýlka doby prestavenia pre DC elektromotory je -50% až +30% v závislosti od zá aže. Pre iné napätia je ± 10%.  
41) Platí len pre vyhotovenie bez vysiela a.  
59) Pre napájacie napätie 24 VAC/DC po dohode s výrobcom.  
62) Pripojovací otvor priamo vo výstupnom hriade li ( bez výmennej vložky ).  
63) Otvor pre výmennú vložku.  
65) Výmenná vložka. Tvar otvoru pripojovacieho dielca pod a dohody.

**Notes:**

- 22) Version 3x400 V (380 V) with additional position switches and double transmitter in agreement with producer.  
28) Version with reverse contacts.  
32) By this torque is possible to load the actuator under duty cycle S2-10 min, or S4-25%, 6-90 cycles per hour.  
33) By this torque is possible to load the actuator under duty cycle S4-25%, 90 - 1 200 cycles per hour.  
34) Deviation of operating speed for the DC electric motor is from -50% up to +30% depending on load. For other voltages the deviation is ± 10%.  
41) Valid for version without transmitter only.  
59) Active position transmitter for version 24 V AC/DC only after agreement with producer.  
62) Connection bore directly within output shaft (without replaceable insert).  
63) Bore for replaceable insert.  
65) Replaceable insert. Profile of hole in connecting part on request.

**Schémy zapojenia \Wiring diagrams\ SP 2.4****Elektrické pripojenie:**

- na svorkovnicu s 24 svorkami s prierezom pripojovacích vodi ov 2,5 mm<sup>2</sup>,  
- cez 3 kábelové vývody: - M20x1,5 pre priemer kábla 8 až 14,5 mm (1 ks),  
- M16x1,5 pre priemer kábla 6 až 10,5 mm (2 ks).

**Electric connection:**

- to terminal board with 24 clamps, wire cross section 2.5 mm<sup>2</sup>,  
- via 3 cable glands: - M20x1.5 for cable diameter 8 to 14.5 mm (1 piece),  
- M16x1.5 for cable diameter 6 to 10.5 mm (2 pcs.).

Schémy zapojenia Wiring diagrams \ SP 1, SP 2, SP 2.3, SP 2.4

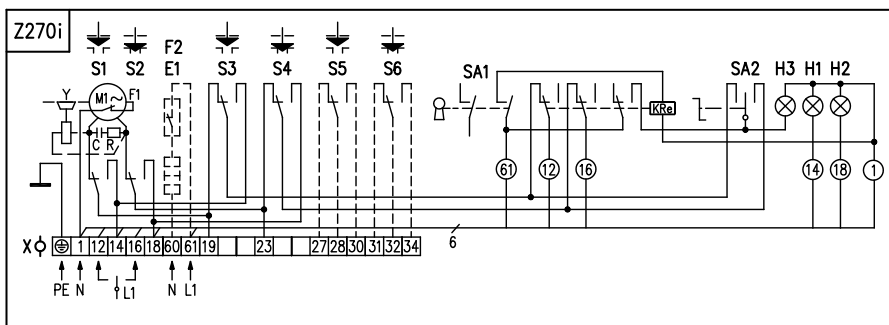
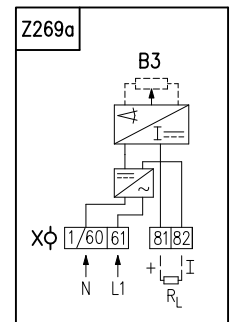
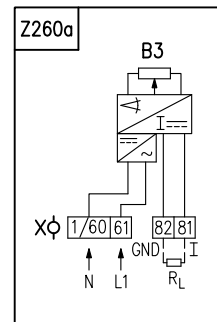
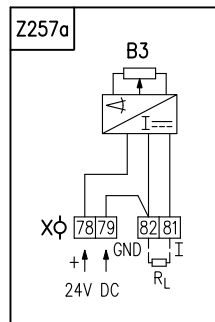
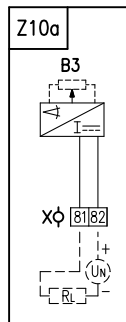
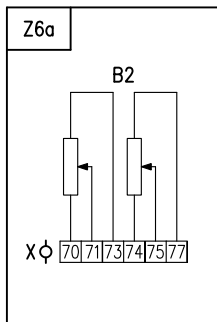
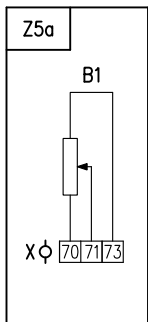
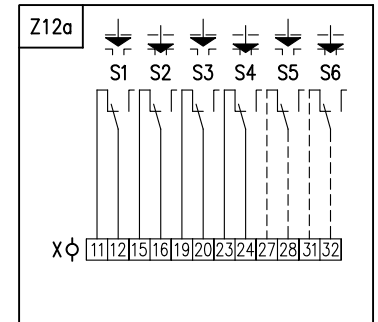
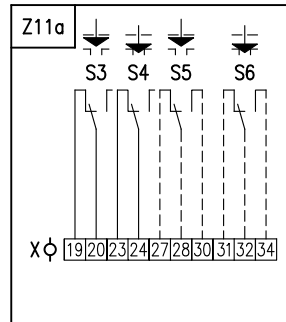
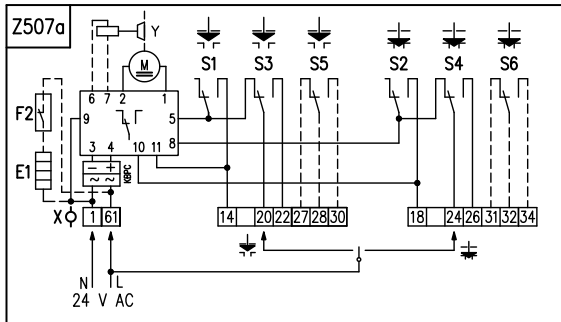
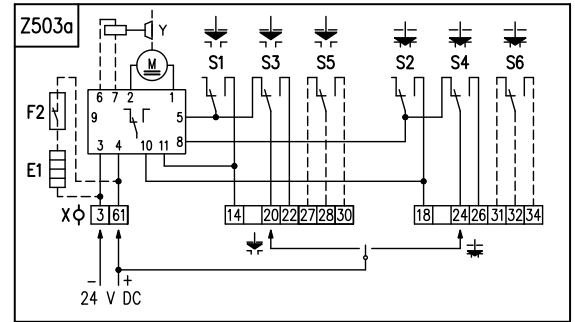
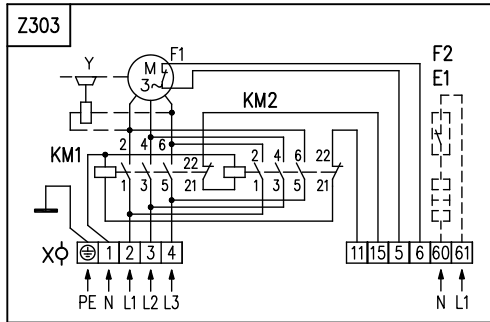
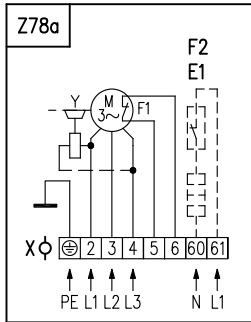
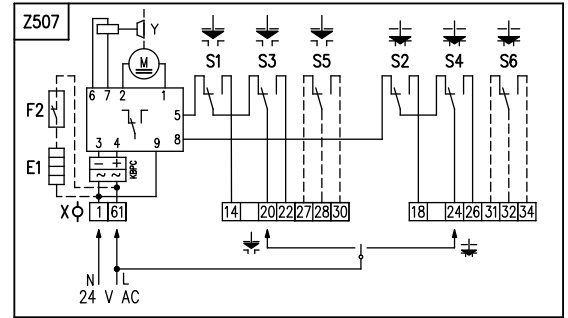
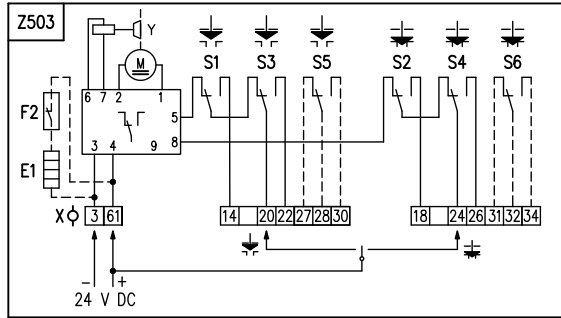
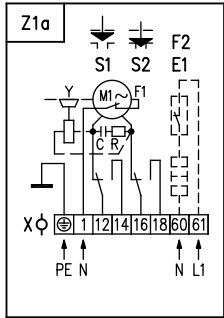

**Poznámky:**

1. Zapojenie je limitované po tom svoriek 24 na svorkovnici servopohonu.
2. Elektromotory sú štandardne vybavené tepelnou ochranou.
3. Vo vyhotovení ES s napájacím napätím 24 V AC nie je potrebné pripoji zemnaci vodi PE.
4. Iné zapojenia servopohonov ako sú uvedené v katalógu sú možné po dohode s výrobcem.

**Notes:**

1. Wiring connection is limited by max. number of 24 terminals.
2. Electric motors are equipped with thermal protection as standard.
3. The version of EA with supply voltage of 24V AC does not require connecting of an earthing cable PE.
4. Different wirings of actuators than shown in the catalogue are possible after agreement with producer.

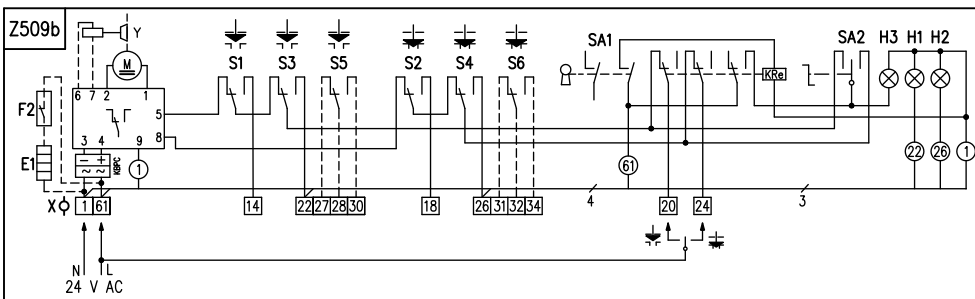
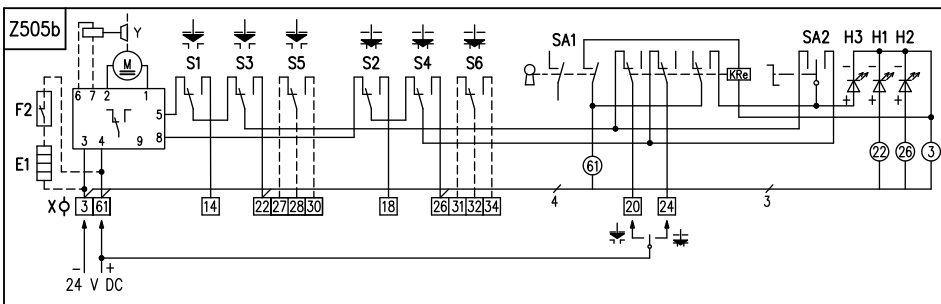
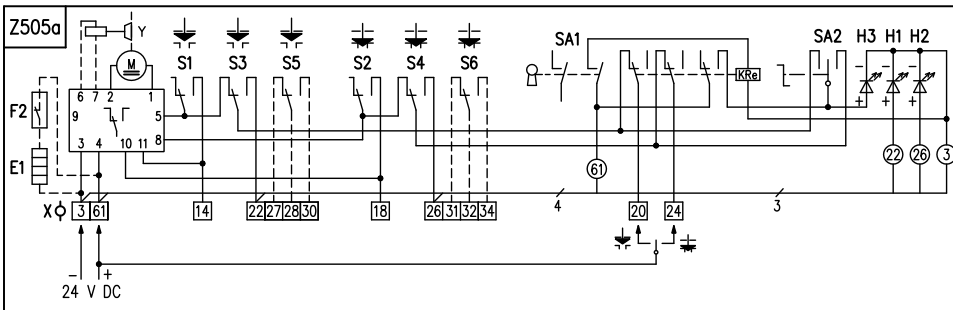
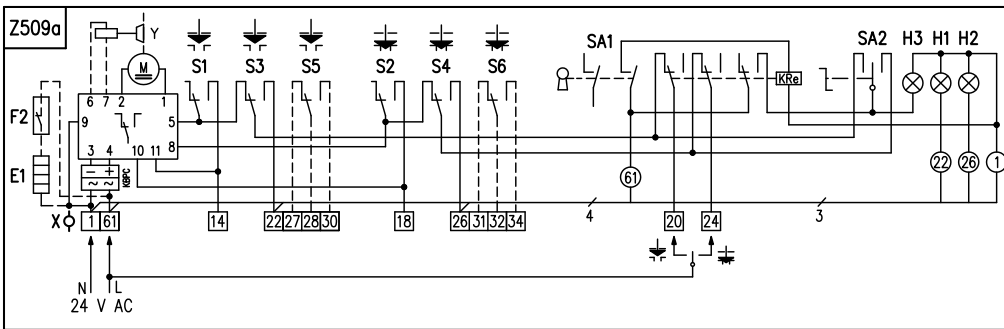
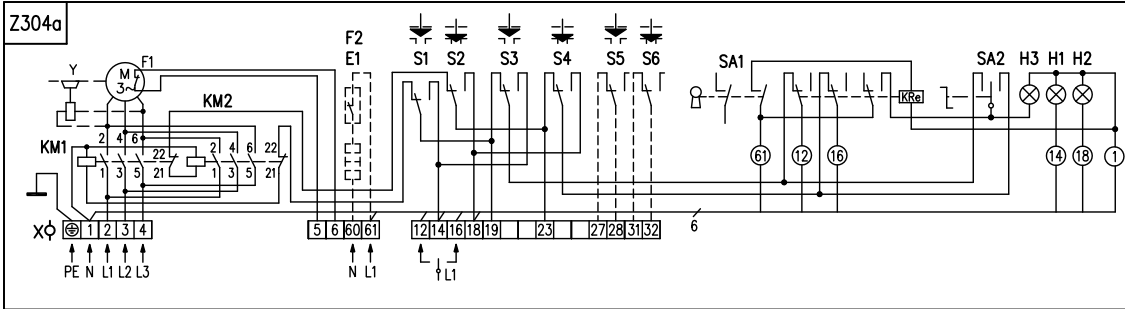
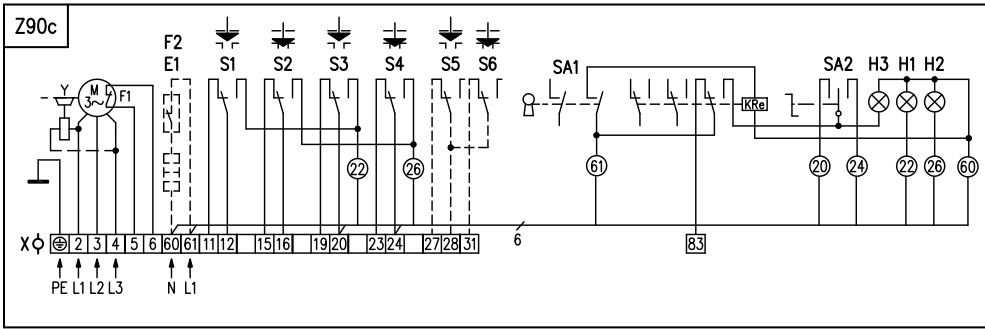

**Legenda:**

Z1a	.....zapojenie 1-fázového elektromotora
Z5a	.....zapojenie jednoduchého odporového vysielu a polohy
Z6a	.....zapojenie dvojitého odporového vysielu a polohy
Z10a	.....zapojenie polohového vysielu a prúdového - 2-vodi bez zdroja
Z11a	.....zapojenie polohových spínačov pre 1-fázový elektromotor
Z12a	.....zapojenie polohových spínačov pre 3-fázový elektromotor
Z78a	.....zapojenie 3-fázového elektromotora
Z90c	.....zapojenie 3-fázového elektromotora s miestnym ovládaním
Z257a	.....zapojenie el. polohového vysielu a prúdového - 3-vodi bez zdroja
Z260a	.....zapojenie el. polohového vysielu a prúdového - 3-vodi so zdrojom
Z269a	.....zapojenie polohového vysielu a prúdového - 2-vodi so zdrojom
Z270i	.....zapojenie 1-fázového elektromotora s miestnym ovládaním
Z303	.....zapojenie 3-fázového elektromotora s reverznými stykami
Z304a	.....zapojenie 3-fázového elektromotora s reverznými stykami a miestnym ovládaním
Z503	.....zapojenie SP 1 s elektromotorom 24 V DC
Z503a	.....zapojenie SP 2, SP 2.3, SP 2.4 s elektromotorom 24 V DC
Z505a	.....zapojenie SP 2, SP 2.3, SP 2.4 s elektromotorom 24 V DC s miestnym ovládaním
Z505b	.....zapojenie SP 1 s elektromotorom 24 V DC s miestnym ovládaním
Z507	.....zapojenie SP 1 s elektromotorom 24 V AC
Z507a	.....zapojenie SP 2, SP 2.3, SP 2.4 s elektromotorom 24 V AC
Z509a	.....zapojenie SP 2, SP 2.3, SP 2.4 s elektromotorom 24 V AC s miestnym ovládaním
Z509b	.....zapojenie SP 1 s elektromotorom 24 V AC s miestnym ovládaním

B1	.....odporový vysielu jednoduchý
B2	.....odporový vysielu dvojitý
B3	.....polohový vysielu prúdový
S1	.....momentový spínač „otvorené“
S2	.....momentový spínač „zatvorené“
S3	.....polohový spínač „otvorené“
S4	.....polohový spínač „zatvorené“
S5	.....prídavný polohový spínač „otvorené“
S6	.....prídavný polohový spínač „zatvorené“
M	.....elektromotor
C	.....kondenzátor
Y	.....brzda elektromotora
E1	.....vyhrievací odpor
F1	.....tepelná ochrana elektromotora
F2	.....tepelný spínač vyhrievacieho odporu
X	.....svorkovnica
I	.....výstupný signál prúdový
H1	.....indikácia koncovkej polohy „otvorené“
H2	.....indikácia koncovkej polohy „zatvorené“
H3	.....indikácia režimu „miestne ovládanie“
SA1	.....otočný prepínač s kúrom „dia kové - 0 - miestne“ ovládanie
SA2	.....otočný prepínač „otvára - stop - zatvára“
R	.....zrážací odpor
R <sub>L</sub>	.....zaťažovací odpor
KM	.....reverzný stykač

**Legend:**

Z1a	.....connection of 1-phase electric motor
Z5a	.....connection of single potentiometer
Z6a	.....connection of double potentiometer
Z10a	.....connection of CPT or electronic position transmitter - 2 - wire, passive
Z11a	.....connection of position switches for 1-phase electric motor
Z12a	.....connection of position switches for 3-phase electric motor
Z78a	.....connection of 3-phase electric motor
Z90c	.....connection of 3-phase electric motor with local controls
Z257a	.....connection of electronic position transmitter - 3 - wire, passive
Z260a	.....connection of electronic position transmitter - 3 - wire, active
Z269a	.....connection of CPT or electronic position transmitter - 2 wire - active
Z270i	.....connection of 1-phase electric motor with local controls
Z303	.....connection of 3 - phase electric motor with reverse contactors
Z304a	.....connection of 3 - phase electric motor with reverse contactors and with local controls
Z503	.....connection of SP 1 with electric motor 24 V DC
Z503a	.....connection of SP 2, SP 2.3, SP 2.4 with electric motor 24 V DC
Z505a	.....connection of SP 2, SP 2.3, SP 2.4 with electric motor 24 V DC with local controls
Z505b	.....connection of SP 1 with electric motor 24 V DC with local controls
Z507	.....connection of SP 1 with electric motor 24 V AC
Z507a	.....connection of SP 2, SP 2.3, SP 2.4 with electric motor 24 V AC
Z509a	.....connection of SP 2, SP 2.3, SP 2.4 with electric motor 24 V AC with local controls
Z509b	.....connection of SP 1 with electric motor 24 V AC with local controls

B1	.....single potentiometer
B2	.....double potentiometer
B3	.....CPT or electronic position transmitter
S1	.....torque switch „open“
S2	.....torque switch „closed“
S3	.....position switch „open“
S4	.....position switch „closed“
S5	.....additional position switch „open“
S6	.....additional position switch „closed“
M	.....electric motor
C	.....capacitor
Y	.....motor's brake
E1	.....space heater
F1	.....motor's thermal protection
F2	.....space heater's thermal switch
X	.....terminal board
I	.....output current signal
H1	.....indication of „open“ limit position
H2	.....indication of „closed“ limit position
H3	.....indication of „electric local control“
SA1	.....rotary switch with key „remote - 0 - electric local“ control
SA2	.....rotary switch „opening - stop - closing“
R	.....reducing resistor
R <sub>L</sub>	.....loading resistor
KM	.....reverse contactor

Rozmerové ná rty \Dimensional drawings\ SP 1, SP 2, SP 2.3, SP 2.4

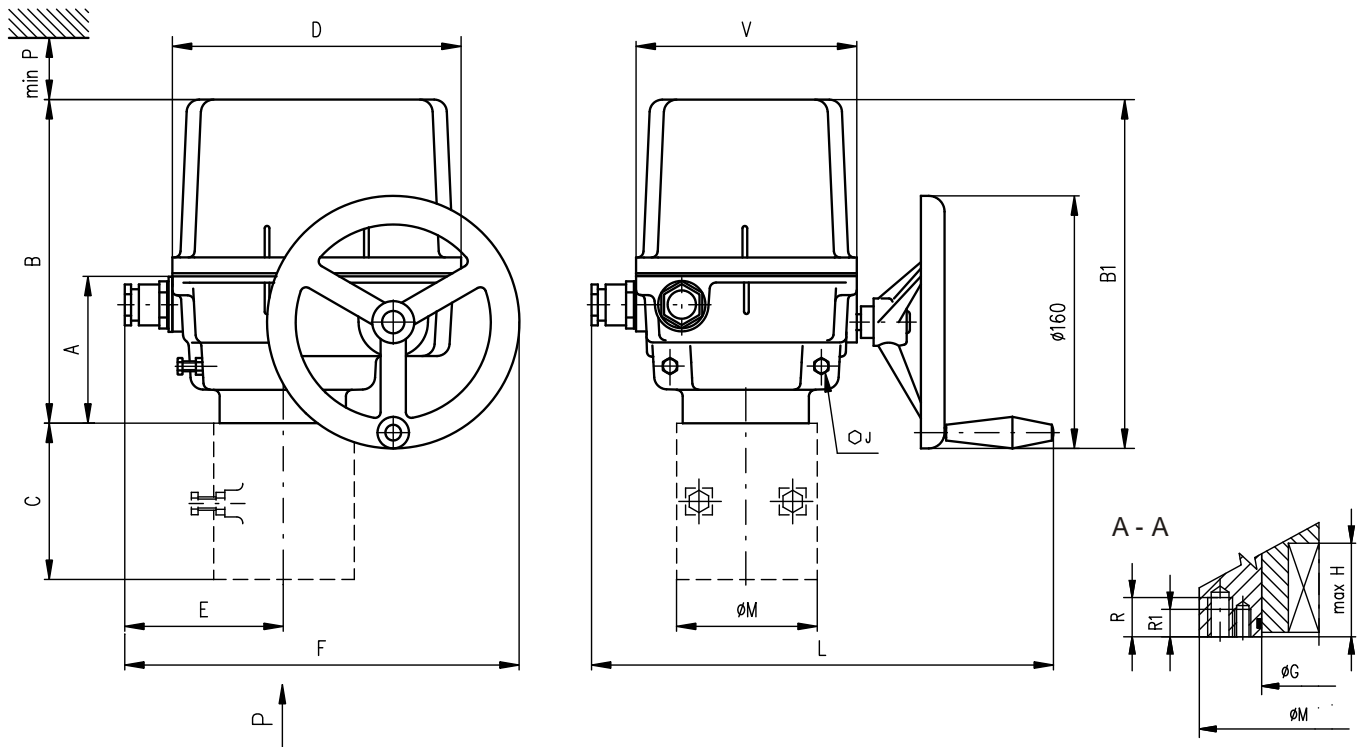

Hlavné rozmery \Main dimensions\

Typ \Type\	A	B	B1	C	D	E	F	J	L	M	P	V
SP 1	102	221	229	-	183	93	243	17	280 396*	90	160	140
SP 2	117	316	323	-	232	119	294	17	330 446*	90	210	190
SP 2.3				22				125				
SP 2.4				127				150				

\* platí pre vyhotovenie s konektorom \valid for version with a connector\

Rozmery prírub \Flange dimensions\

Typ \Type\	G	H	R	R1	S	S1	T	T1	Ve kos príruby \Flange size\
SP 1	40	37	16	14	70	50	M8	M6	F07/F05
SP 2	40	49	18	14	70	50	M8	M6	F07/F05
SP 2.3	55	56	25	17	102	70	M10	M8	F10/F07
SP 2.4	65	71	30	25	125	102	M12	M10	F12/F10

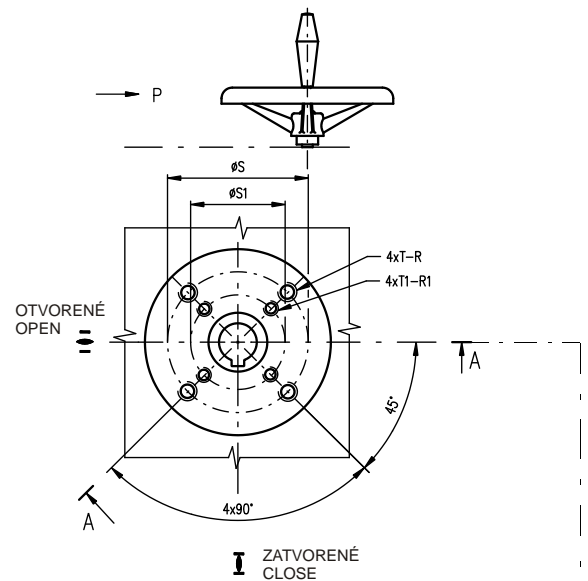

Tvar pripojovacieho dielca \Coupling shape\										
D-xx		L-xx		H-xx		V-xx		V-30, V-45.4		
ISO	Rozmer \Dimension\	ISO	Rozmer \Dimension\	ISO	Rozmer \Dimension\	ISO	Rozmer \Dimension\			
D-xx	U	L-xx	U	H-xx	U	V	V-xx	W	Z	X
D-14	14	L-14	14	H-14	14	22	V-20	20.0	22.5	6.0
D-17	17	L-17	17	H-11	11	18	V-22	22.0	24.5	6.0
D-22	22	L-22	22	H-8	8	13	V-32.2	32.2	35	6.5
D-27	27	L-27	27	H-17	17	25	V-17	17.0	19.5	6.0
D-11	11	L-11	11	H-13	13	19	V-28	28.0	30.9	8.0
D-16	16	L-16	16	H-22	22	32	V-42	42.0	45.1	12.0
				H-16	16	22	V-45.4	45.4	48.8	10.0
				H-27	27	48	V-50	50.0	53.5	14.0
				H-19	19	28	V-18	18.0	20.5	6.0
				H-10	10	16	V-30	30.0	32.5	8.0

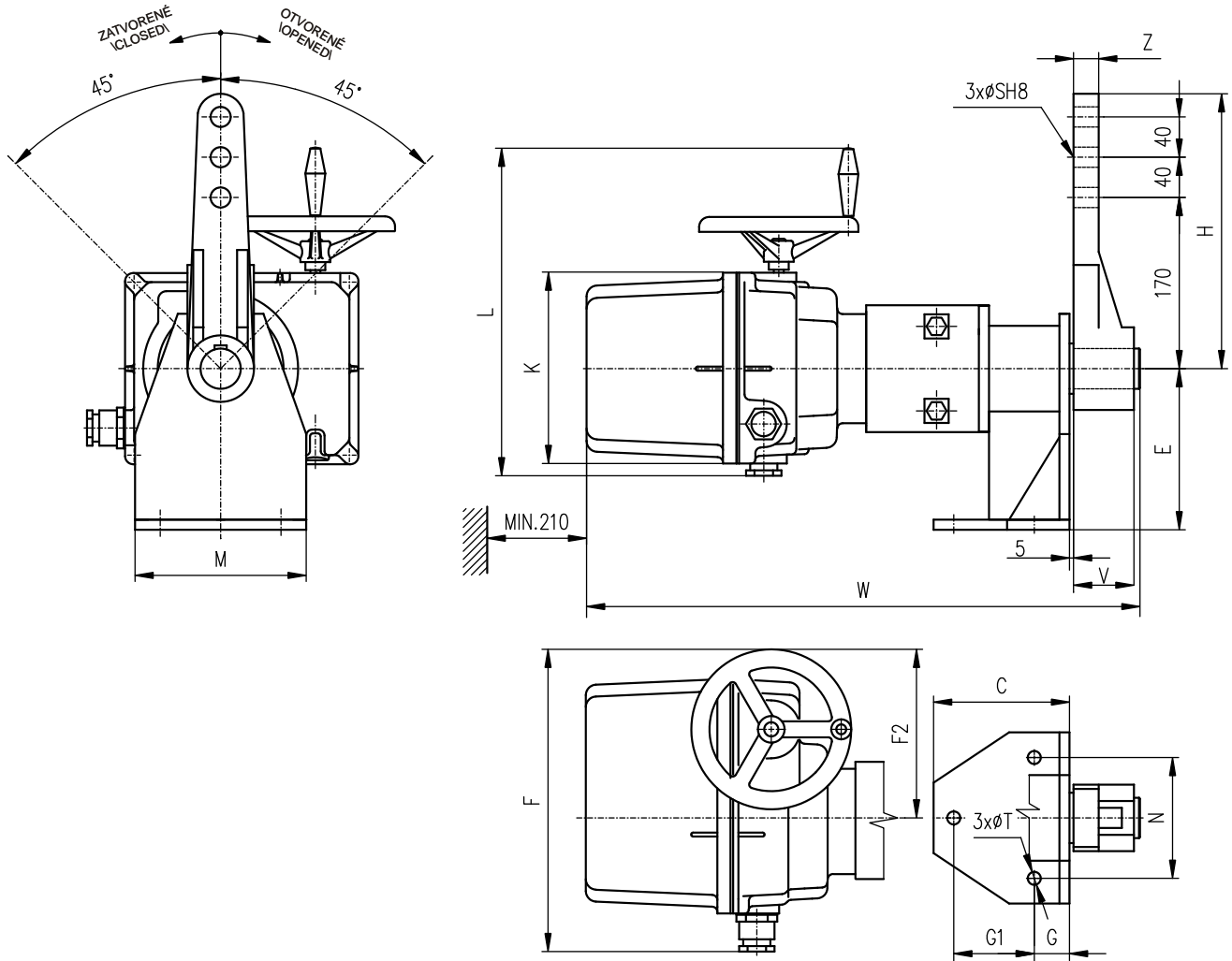

Hlavné rozmery \Main dimensions\

Typ \Type\	C	E	F	F2	G	G1	H	W	K	L	M	N	S	T	V	Z
SP 2.3	135	160	294	175	35	80	278	584	190	330 446*	170	120	20	13	56	20
SP 2.4	200	220	294	175	60	120	278	654	190	330 446*	228	170	25	17	80	30

\* platí pre vyhotovenie s konektorom \valid for version with a connector\

Vyhotovenie servopohonu SP 2.3 a SP 2.4 so stojanom a vo ným koncom hriade a  
 \Version SP 2.3, SP 2.4 with stand and free shaft\

Tvar pripojovacieho dielca E \Coupling shape E\

Typ \Type\	H	S	U	V	Z	Y	Y1	Tvar pripojovacieho dielca \Coupling shape\
SP 2.3	43.1	40	12	66	56	4	7	E03
SP 2.4	53.8	50	16	82	70	4	7	E04

P - 1395

ahadlo TV 40-1/20 TV 50-1/25  
 \Pull-rod TV 40-1/20 and TV 50-1/25\

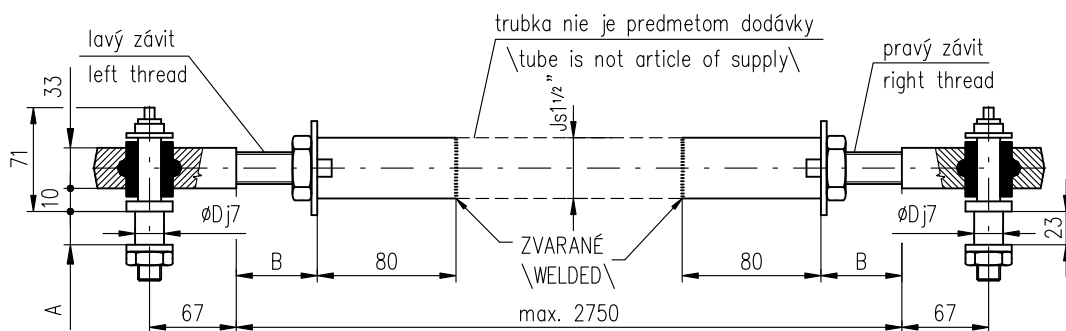

P-1413/B	SP 2.4	TV 50-1/25	28	Min.30	25
P-1413/A	SP 2.3	TV 40-1/20	23	Max.50	20
Vyhotovenie \Version\	Typ \Type\	Typ ahadla \Pull-rod version\	A	B	D

P - 1413

Vyhotovenie servopohonov SP 2.3 a SP 2.4 s miestnym ovládaním  
 \Version of SP 2.3 and SP 2.4 actuators with electric local control\

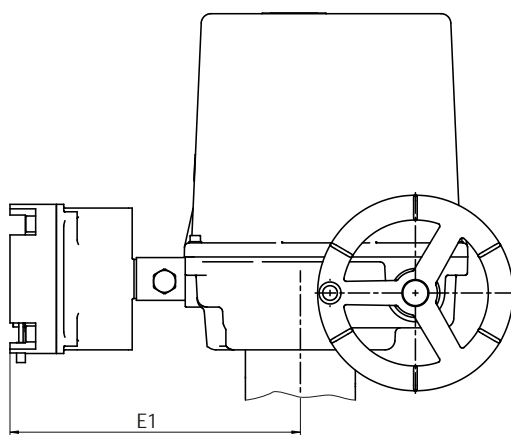

SP 2.4	-25° / -50 C°	198
SP 2.3	-25° / -50 C°	198
Typ \Type\	Teplota \Temperature\	E1

alšie rozmery pod a základných rozmerových ná rtov.  
 \Other dimensions according to basic dimensional drawings\

P - 2148/F